

iCIP® Solar Solutions® Pump

Series 100, 200, 300, 400

INTELLIGENT CHEMICAL INJECTION PUMP

**Revision 1.1.7.4**

INSTALLATION & OPERATIONS PROCEDURES MANUAL

Class I Division 2

Table of Contents

Introduction	1	Configuration Firmware.....	12
Serialized Assemblies	1	Firmware Installation Upgrade.....	12
Installation Instructions	2	Motor Controller Enclosure	12
Solar Panel Mounting	2	Solar Converters.....	12
Solar Panel Alignment.....	2	Gel Cell Battery.....	13
Solar Panel Maintenance	4	Simplex/Duplex/Triplex Pump.....	13
Solar Panel Wiring	4	Electric Motor	13
Battery Enclosure	4	Pump Packing Tightness & Adjustment	13
Pump & Motor Installation.....	5	Head Adjustment.....	14
Motor Wiring Extension Harness.....	5	iCIP Pump Setup Examples.....	15
Battery Wiring & Installation	5	Wiring Diagrams	16
Quick Set Pump Starting Parameters	6	Servicing	18
Manual Input Map of Pump Operations	8		

Introduction

The benefits of solar powered chemical injection pumping systems offered by Dresser will provide years of low maintenance, clean reliable service, zero noise pollution, without emissions to the surrounding environment. Our goal is to pass along a quality product, both a renewable resource and affordable investment to our customers.

To insure quality of product, functionality, operating procedures, warranty and service pertaining to equipment provided by Dresser to our customers, consult a qualified manufacturing representative.

THIS EQUIPMENT IS SUITABLE FOR USE IN CLASS I DIVISION 2, GROUPS C&D OR NON-HAZARDOUS LOCATIONS ONLY.

Serialized Assemblies

It is strongly advised that all assemblies remain a complete or unbroken serialized set for proper functionality. These assemblies have been adequately sized based on the following variables: Daily Solutions Volume, Head Size, Well Pressures, Regional Solar Hours, Temperature, Number of Days without Sun Light, and Quantities of Batteries and Solar Panels.

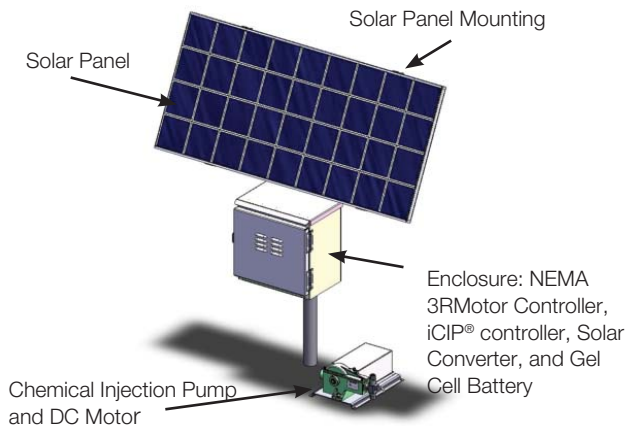

Figure 1 – iCIP® (Intelligent Chemical Injection Pump) Pump General Configuration

Installation Instructions

The iCIP® (Intelligent Chemical Injection Pump) pump assembly comes with connections which are provided to protect against accidental electrical shock. There are connectors inline provided for both the battery(s) and the solar panel(s). *The connectors should not be connected while the iCIP® pump is being assembled or during any maintenance period.*

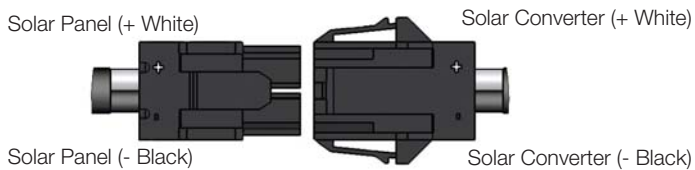

Figure 2– Solar Panel and Battery Connections

A 2.0 inch diameter schedule 40 galvanized coated 6 foot mounting pole has been provided for attaching both the Solar Panels and Battery Enclosure. The pole can be firmly attached to a leg of a solutions tank rack. An alternative method for securing the mounting pole would be to drive a T-post into the ground, slip the pole over the T-post and add a generous amount of Quick-Set concrete to the top opening of the pipe.

U-bolts have been included to secure the battery enclosure to the mounting pole. The distance from the ground to the underside of the enclosure should be approximately 36 inches. This will allow the operator to sit comfortably on a stool while making input changes to the Motor Controller or to isolate the solar panel and battery power supplies for routine maintenance. Avoid over tightening of the U-bolt nuts to prevent damage to the battery enclosure.

For Safety purposes, the battery and solar panels should not be connected until all other assembly steps have been completed.

Solar Panel Mounting

Mounting hardware to attach the solar panels to the pole has been pre-assembled to aid in field installation. Prior to placement of the 3-outlet 2.0 inch diameter Pipe Tee, loosen the Azimuth (direction the solar panels face) adjustment Set Screw. Reference Figure 3. Position the bottom inlet on top of the pole, making sure it is firmly centered and seated down. Make sure that there aren't any shadows that could contact any portion of the solar panel.



Solar Panel Alignment

During “sun hours” the solar panels are used to recharge the battery voltage used during the night or non sun hours. The solar mounting assembly should be adjusted to achieve Maximum Effective Irradiance or Maximum Peak Power (maximum sun hours). Configuring the azimuth (direction the solar panels face) and horizontal (tilt) placement of the Solar Panels is critical and should be adjusted or aligned at midday to achieve maximum “sun hours”.

To adjust both the direction the Solar Panels face and the tilt positions on the Solar Panel Mounting, there are (3) 5/8 in.- Set Screws on the 3-outlet 2.0 in. diameter Pipe Tee component of the mounting assembly, which will require a 5/16 Allen Wrench. Reference Figures 3 and 4.

STEP 1: Direction: Adjust the Solar Panel Array Azimuth (direction the solar panels face) by facing the assembly towards true South, not magnetic south. True South (Solar Noon) is defined as the position halfway between Sunrise and Sunset. Determine the halfway point between sunrise and sunset for a given day, and face the solar panels in that direction.

STEP 2: Tilt: Dresser recommends the tilt angle be set for winter or the winter solstice (December 21). Use one of the following methods to set the tilt of the solar panels.

Method 1: Reference Figure 6 to obtain the desired Tilt angle with respect to the latitude of the end customer's well location on the right side of the graph. Follow the curve across the graph to the left side to “Photovoltaic Module Angle (Deg.)” with reference to the horizontal plane. Use a cheap protractor, and a foot long piece of string with a small weight attached to the end to set the tilt of the solar panels.

Method 2: First, determine the latitude of the install location. Then subtract the Sun Declination Angle (-23.5°) from the latitude. This method for finding this angle can be seen in the following example provided. Reference Figure 4.

Tilt Angle = Latitude Angle – (Declination Angle).

Example: Site: Houston TX, Latitude = 29°8'

Latitude (29.8°) – Declination Angle (-23.5°) = 53.3°

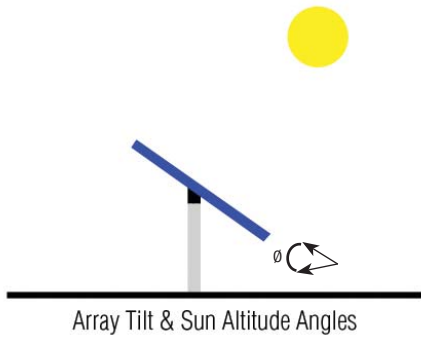

Figure 4

After adjusting the Azimuth and Tilt angle, tighten down the set screws that secure the 3-outlet Pipe Tee fitting to the 2.0 in. mounting pole.



Figure 5

Solar Panel Angles for Various Latitudes

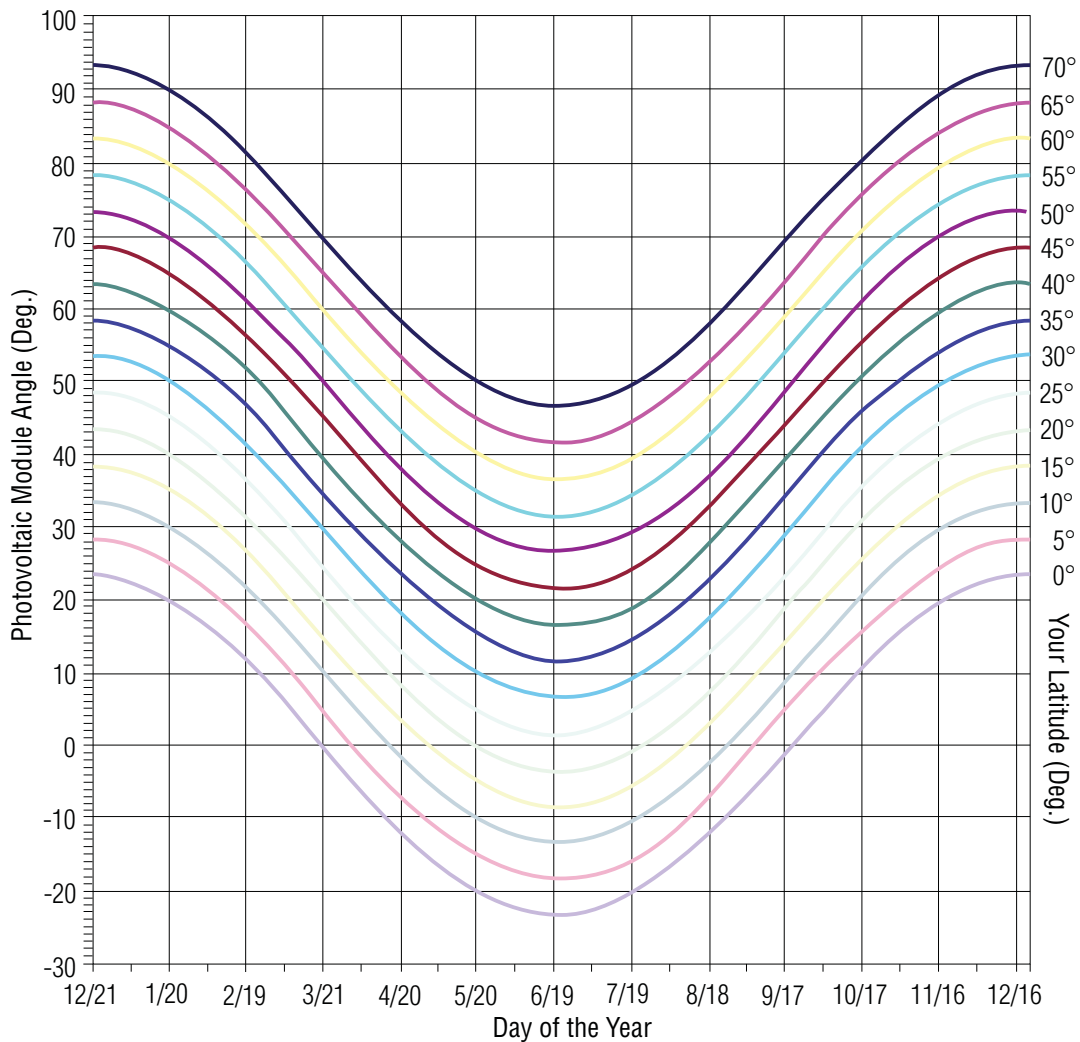

Figure 6 – Solar Panel Tilt vs. Well Latitude Location

Solar Panel Maintenance

Very little maintenance is necessary other than the periodic cleaning of the Solar Panel screen. This will optimize the charging capabilities, by enhancing the light transmission. Use a mild soap solution, warm water and a clean soft towel to remove dust, bird dropping, etc. Use of any greasy substances or sharp tools might scratch the protective covering.

Handle the solar panels with care. The cells can easily be damaged do the fragile nature of the multicrystalline silicon cell structure. Irreparable damage can be caused by any impacting, twisting, or bending action of the panel assemblies. Do not drill or weld the frame if possible.

Solar Panel Wiring

Panels Provided with Unit: Using a piece of cardboard, keep the Solar Panels covered while making any electrical connection to the Solar Panel Junction box. Follow the instructions and wiring diagram (reference Figure 16) for proper polarity connectivity. Always use insulated tools to avoid high voltage and current produced by the solar panels. Install the cable glands as needed into the side of the Solar Panel Junction box. Position a screw driver on the diameter of the circular plastic plug to remove the knockout. Install the cable gland, avoiding over tightening. Slide power cable through the cable gland and hook up white wire to positive contact and the black wire to negative contact. Where multiple panels are used, unless only one solar panel cable is protruding from the battery enclosure, all Solar Panels are to be wired to a unique solar panel cable assembly. In some instances, two panels will be wired in parallel (connecting Positive to Positive and Negative to Negative). Close the junction box and secure the lid using the captive screws provided.

A simple plug/socket assembly has been provided to isolate or to disconnect the power from the Solar Panels to the electrical charging system for safety and general maintenance.

Do not plug in until all other connections have been completed. After all connections have been made, remove the cardboard cover.

Panels Provided by Customer: Using a piece of cardboard, keep the Solar Panels covered while making any electrical connection to the Solar Panel Junction box. Follow the instructions and wiring diagram (reference Figures 21-24) for proper polarity connectivity. Always use insulated tools to avoid high voltage and current produced by the solar panels. Route the solar panel wiring through the enclosure opening (Figure 7). Install and tighten the cable gland connector into the side of the enclosure. Each solar panel wiring assembly should be routed through a unique opening.

In some instances, two panels will be wired in parallel (connecting Positive to Positive and Negative to Negative).

A simple plug/socket assembly has been provided to isolate or to disconnect the power from the Solar Panels to the electrical charging system for safety and general maintenance.

Do not plug in until all other connections have been completed. After all connections have been made, remove the cardboard cover.

For Safety purposes, the battery and solar panels should not be connected until all other assembly steps have been completed.

Route the solar panel cable through enclosure opening

Motor Connection



Figure 7

Motor Controller Enclosure

NEMA 4X Rated

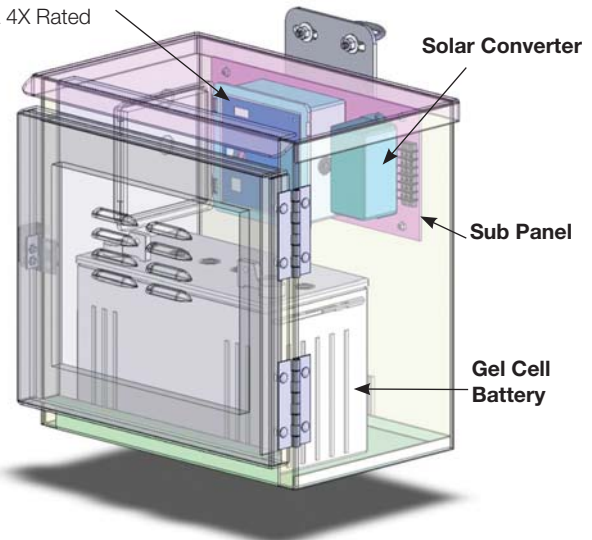

Figure 8 – Enclosure: Battery, Motor Controller, and Solar Converter

Battery Enclosure

The Battery Enclosure is constructed from a marine grade all aluminum exterior shell, neoprene door seal, security latch, and front ventilation. The enclosures are available in 1-5 battery types that are rated and meet NEMA 3R-rating. For 1, 2, 3 Battery Enclosures use the two U-bolts provided, to mount the empty Battery Enclosure firmly to the secured 6 foot pole, approximately three feet from the ground to the underside of the enclosure. Over tightening of the U-bolts should be avoided. The 4 battery enclosure is a top hinge type chest which will lay on the ground. The Motor Controller, Solar Converter and Terminal Strip come pre-assembled on the Sub Panel from Dresser. This Sub Panel is located on the upper back wall of the Battery Enclosure. It has been secured and is offset from the back mounting surface of the enclosure using four #10-32UNC Studs.

Motor and Pump Install

Connect the DC motor cable end (circular connector) to the mating connector (panel mount) on the battery enclosure. Reference Figure 7. A standard 6 foot motor wire harness comes pre-assembled using a 14+ P CID2 all weather connecting receptacle. This connection can easily be connected and disconnected for ease of installation or relocation. Reference Figure 9.



Figure 9

Motor Wiring Extension Harness

An additional 14 foot Wiring Harness Extension for 24 Volt motor is available only through Dresser manufacturing facilities. P/N SP2100 Extension Cable will be provided with (2) 14 + P CID2 all weather connecting receptacles.

Battery Wiring Install

Once the enclosure has been mounted onto the pole or placed on the ground, the battery(s) can then be inserted into the battery enclosure. Reference Figures 10-12 and schematics for wiring and installation steps.

On multiple battery installations, a ground wire has been provided to be connected from battery negative to battery negative. The black wire should be connected from a negative battery post to the negative connection on the terminal block on the enclosure backplate.

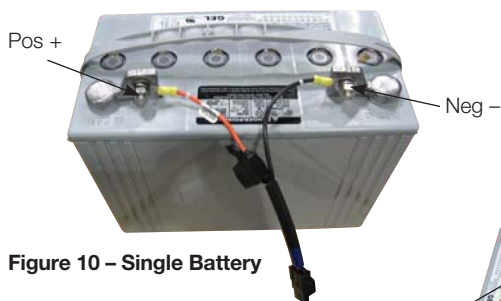

Figure 10 – Single Battery

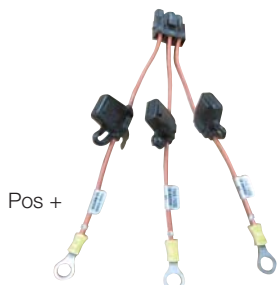

Figure 12 – Triple Battery Positive Cable End

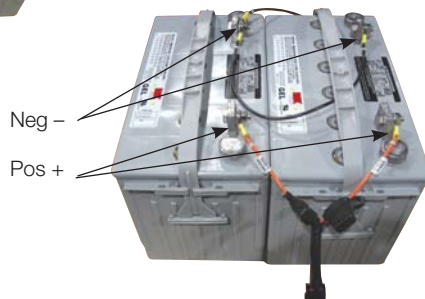

Figure 11 – Double Battery

Supply Power to iCIP® Pump

Connect color coded cable(s) from battery to same cable with color coded connector within enclosure that terminates to terminal block.

Connect color coded cable(s) from solar panel to same color coded connector within enclosure that terminates to terminal block.

The system should now be operational. The LED display on the controller should be illuminated.

Quick Set Pump Starting Parameters

1. Toggle down through the menu tree (Reference Figure 14) using the joystick control (Reference Figure 13). Go to “SETUP/UNITS” and pick the units of measure US (Quarts/Day) or SI (Liters/Day). Press down on the joystick, “DONE” should be displayed.
2. Next go to “SETUP/HEAD SIZE” or Pump Head Size. This will automatically set the pump displacement with regards to the cam and plunger diameter. Select one of the following head sizes: 3/16, 1/4, or 3/8 depending on the size delivered.

Press down on the joystick, “DONE” should be displayed. Select the head size based on the volume requirements based on Table 1 for 45 RPM motors and Table 2 for 65 PRM motors.
3. Lastly go to “SETUP/DAILY VOLUME” and hold down the joystick either up or down to increase or decrease the daily volume. Press down on the joystick, “DONE” should be displayed. Daily volume is dependant on the units of measure selected above in Step 1 and head size.
4. Toggle up to “OPERATION”, move the joystick to the right and select “RUN”, press down on joystick, “DOWN” should be displayed, and the iCIP pump should now be operating and pumping.

For 45 RPM Motor Select the Head size based on the volume required on Table 1

Head Size	# of Heads	RPM Range		Volume Range		Units of Measure	Pressure Range (psi)	
		Low	High	Low	High		Standard	High Pressure
3/16"	Single	5	45	1.75 (1.66)	26.31 (24.87)	Quarts (Liters)/Day	0 – 5000	5000 – 7000
	Duplex	5	45	1.75 (1.66)	52.62 (49.79)	Quarts (Liters)/Day	0 – 5000	5000 – 7000
	Triplex	5	45	1.75 (1.66)	73.93 (74.69)	Quarts (Liters)/Day	0 – 5000	5000 – 7000
1/4"	Single	5	45	3.07 (2.91)	46.07 (43.61)	Quarts (Liters)/Day	0 – 5000	0 – 5000
	Duplex	5	45	3.07 (2.91)	92.14 (87.19)	Quarts (Liters)/Day	0 – 5000	0 – 5000
	Triplex	5	45	3.07 (2.91)	138.21 (130.79)	Quarts (Liters)/Day	0 – 5000	0 – 5000
3/8"	Single	5	45	11.52 (10.90)	103.68 (98.12)	Quarts (Liters)/Day	0 – 1500	1500 – 3000
	Duplex	5	45	1.52 (10.90)	207.36 (196.23)	Quarts (Liters)/Day	0 – 1500	0 – 1500
	Triplex	5	45	1.52 (10.90)	311.04 (295.35)	Quarts (Liters)/Day	0 – 1500	0 – 1500
1/2"	Single	5	45	20.48 (19.38)	184.29 (174.43)	Quarts (Liters)/Day	0 – 1000	0 – 1000
	Duplex	5	45	20.48 (19.38)	368.58 (348.80)	Quarts (Liters)/Day	0 – 1000	0 – 1000
	Triplex	5	45	20.48 (19.38)	552.87 (523.10)	Quarts (Liters)/Day	0 – 500	0 – 500

Table 1 – Head Size vs. Volume Range

For 65 RPM Motor Select the Head size based on the volume requirements on Table 2

Head Size	# of Heads	RPM Range		Volume Range		Units of Measure	Pressure Range (psi)	
		Low	High	Low	High		Standard	High Pressure
3/16"	Single	5	65	2.9 (2.8)	38.0 (35.9)	Quarts (Liters)/Day	0 – 5000	5000 – 7000
	Duplex	5	65	2.9 (2.8)	76.0 (71.9)	Quarts (Liters)/Day	0 – 5000	5000 – 7000
	Triplex	5	65	2.9 (2.8)	114.0 (107.8)	Quarts (Liters)/Day	0 – 5000	5000 – 7000
1/4"	Single	5	65	5.1 (4.8)	66.6 (63.0)	Quarts (Liters)/Day	0 – 5000	0 – 5000
	Duplex	5	65	5.1 (4.8)	133.2 (126.0)	Quarts (Liters)/Day	0 – 5000	0 – 5000
	Triplex	5	65	5.1 (4.8)	199.8 (189.0)	Quarts (Liters)/Day	0 – 5000	0 – 5000
3/8"	Single	5	65	11.5 (10.9)	149.8 (141.7)	Quarts (Liters)/Day	0 – 1500	1500 – 3000
	Duplex	5	65	11.5 (10.9)	299.6 (283.5)	Quarts (Liters)/Day	0 – 1500	0 – 1500
	Triplex	5	65	11.5 (10.9)	449.4 (425.2)	Quarts (Liters)/Day	0 – 1500	0 – 1500
1/2"	Single	5	65	20.5 (19.4)	266.2 (252.2)	Quarts (Liters)/Day	0 – 1000	0 – 1000
	Duplex	5	65	20.5 (19.4)	532.4 (503.8)	Quarts (Liters)/Day	0 – 1000	0 – 1000
	Triplex	5	65	20.5 (19.4)	798.6 (755.7)	Quarts (Liters)/Day	0 – 500	0 – 500

Table 2 – Head Size vs. Volume Range

Motor Controller and Solar Solution Series Options

The Motor Controller has been designed to provide four different configuration packages, series 100, 200, 300, and 400. Reference Figure 14.

- The Basic “Solar Solutions Series 100” will incorporate the following
 - Programmable controller w/ 4-digit LED display
 - Manual input capabilities utilizing 5 position joystick
 - Continuous duty motor
 - RS232 communication interface. Configurations files can be downloaded with the aid of a laptop PC. These configurations files are easily saved and stored in an Excel or XLS format.
 - Viewable diagnostic parameters
 - Field proven Textsteam pump
 - MPPT solar panel charge controller with charge management
 - Gel cell batteries
 - Low battery management
 - Programmable volumes from 1.75 Qt/day to 184 on a simplex unit with the 45 RPM motor and 2.92 Qt/day to 266 with the 65 RPM motor
 - Pressure from 0 – 7000 psi available
 - Alarm configuration
 - Schedule configuration
 - CSA/UL certification option
- The “Solar Solutions Series 200” or “Data Logging” Module will incorporate the following
 - All of the features of the “Solar Solutions Series 100”
 - Ability to logg /store / save data
 - Easy time frequency between logged data
 - Capture data at a maximum of 1440 minutes (20,000 record capacity) of on-site pump data, such as power consumptions, battery charge condition, solar panel output wattage, pumping total volume, ambient temperature, well pressure, tank level, alarm or security protocol. This data can be accessed and retrieved using an on-site laptop via the RS232 bus with the UserTerminal iCIP pump software or via RS485 interface.

- The “Solar Solutions Series 300” or “Communications” Module will incorporate the following
 - All of the features of the “Solar Solutions Series 100”
 - The ability to remotely access or communicate live pump data from the controller/system via a Modbus over a non-Isolated RS485 half duplex (bi-directional) serial communication port and displayed on a screen or monitor live conditions of on-site pump data. RS-232 Communication Baud Rates or BPS (bits per Second) Transmission Speeds available: 1200, 9600, and 19200
- The fourth or “Series 400” will integrate both the “Solar Solutions Series 200” and “Solar Solutions Series 300”.

Note that in the scheduling time parameters the time “ON” is in seconds, but the time “OFF” is in minutes.

Options

- Analog and digital inputs and outputs. The I/O are available in two configurations
 - 2 I/O option – two analog or digital inputs or outputs
 - 12 I/O - The following I/O are available
- Five analog inputs
- One analog output
- Three digital inputs
- Three digital outputs
- High pressure option – The high pressure enables the pump to achieve higher than standard pressure ranges.
- Power supply option – Power supplies are available to run the iCIP pump from either a 120VAC or 24DC electrical supply
- Adjustable plunger – Adjustable stroke length pumps are available on the second and third head of duplex or triplex systems
- Lockout / Tagout switch – A keyed switch located on the outside of the enclosure to disable the motor during scheduled maintenance.
- Motor disconnect switch – A switch located on the outside of the enclosure used to disable the motor during schedules maintenance.
- Pressure transducer – Pressure transducers are available for a wide range of pressures desired.
- Ultrasonic tank level – An ultrasonic transducer available of a wide range of tank sizes.



Menu Trees

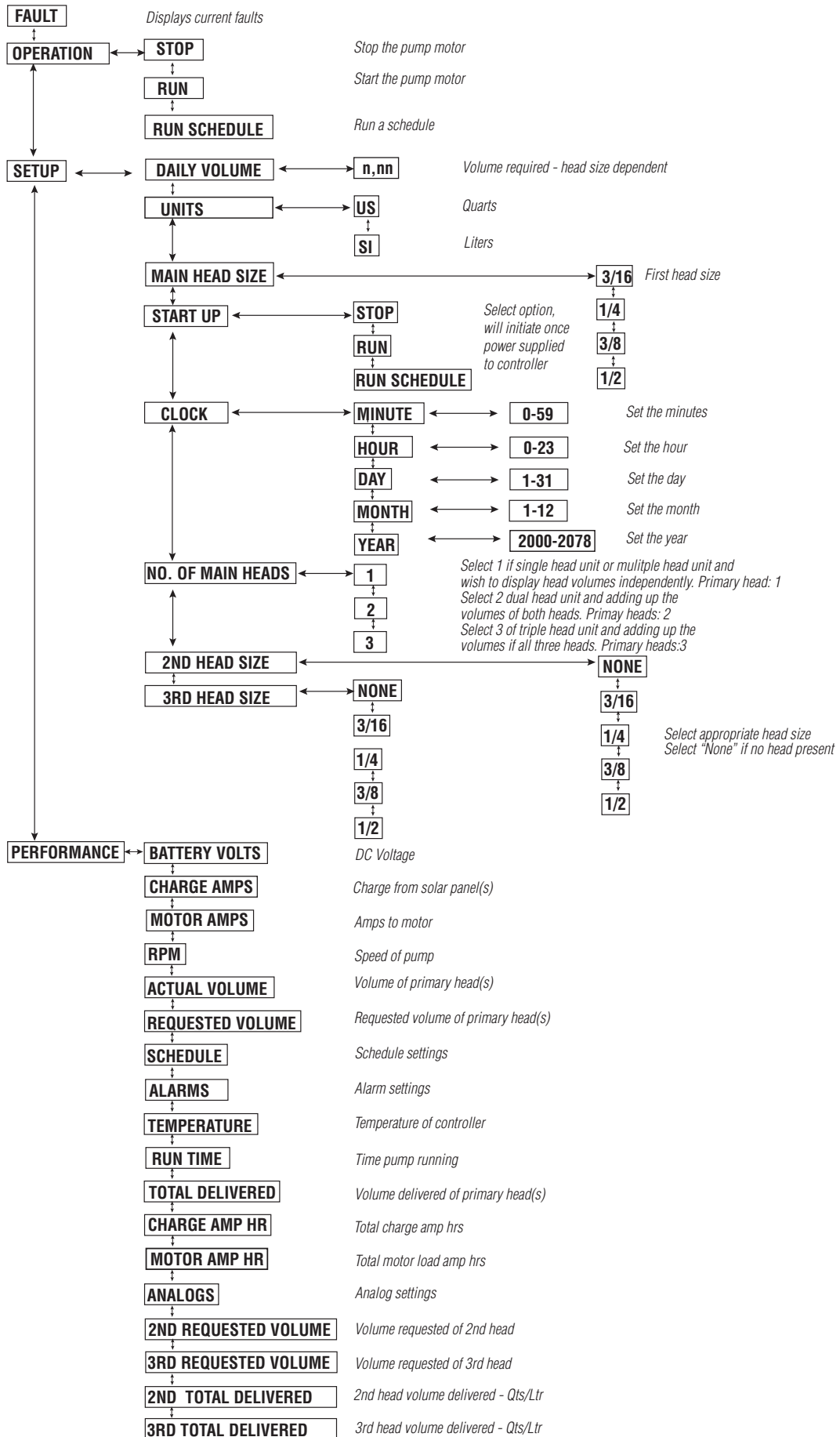

iCIP Controller Menu Tree - Advanced

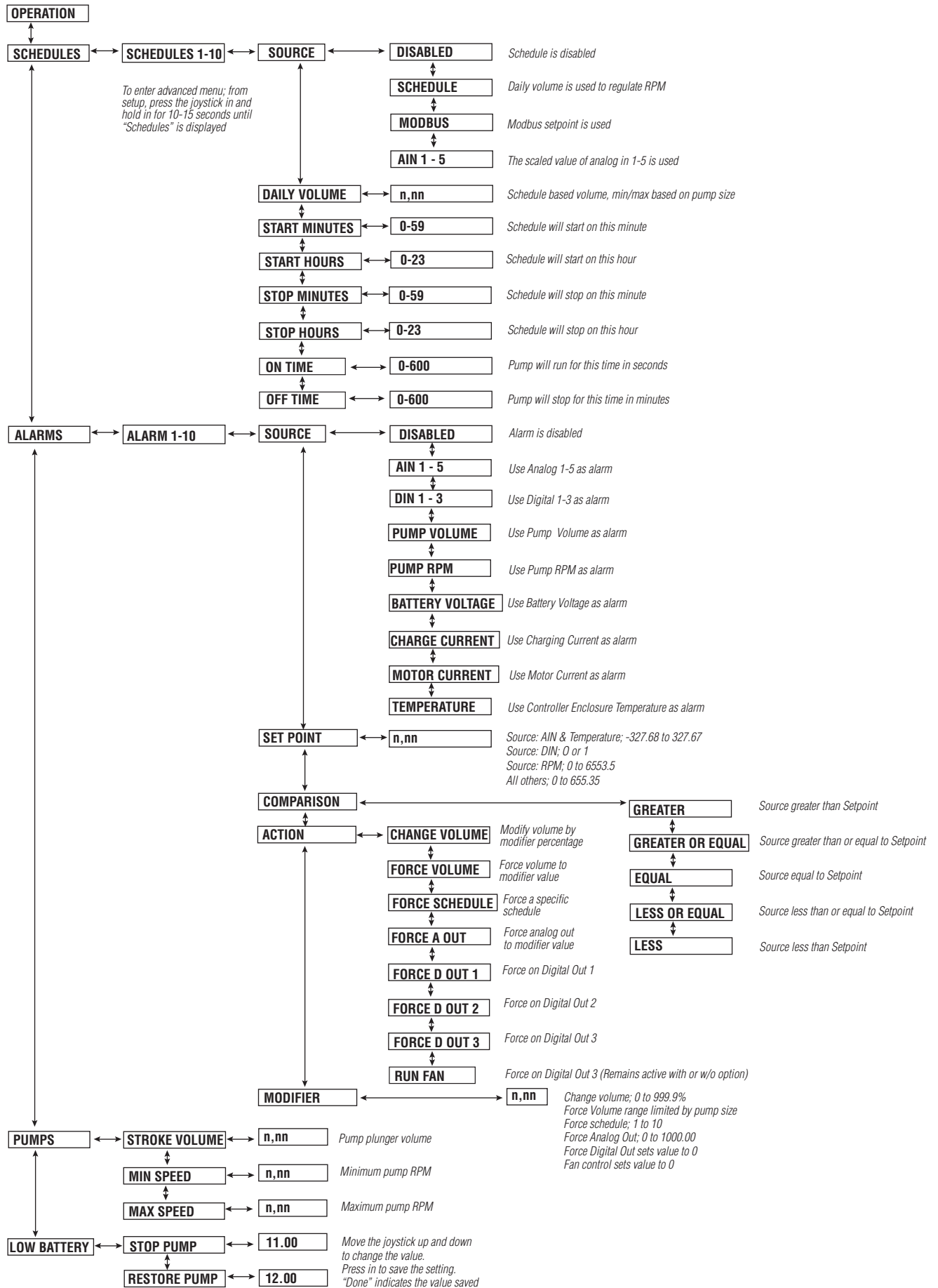

iCIP Controller Menu Tree - Analog & Digital Inputs & Outputs Setup

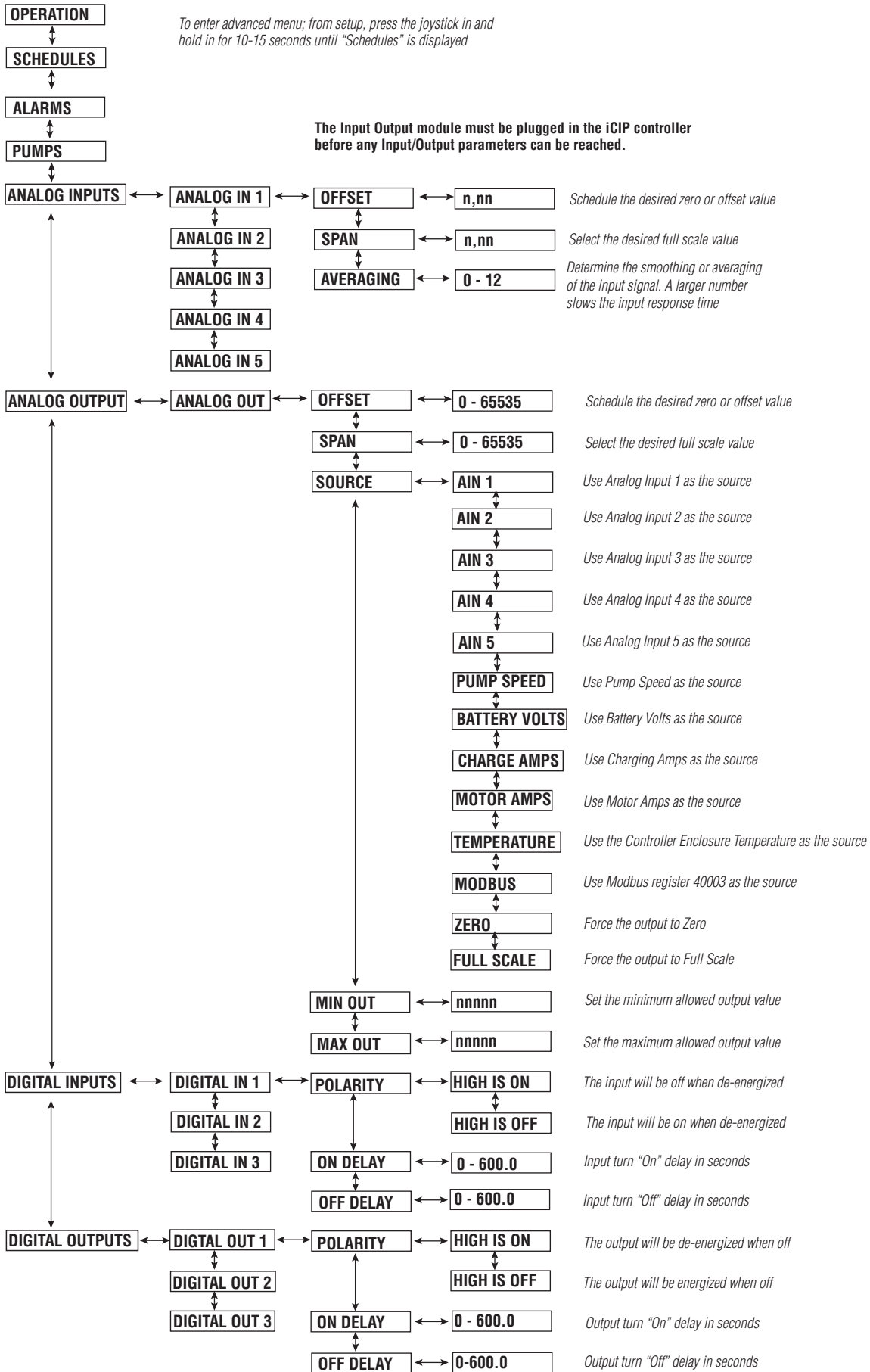

iCIP Controller Menu Tree - Logging Setup

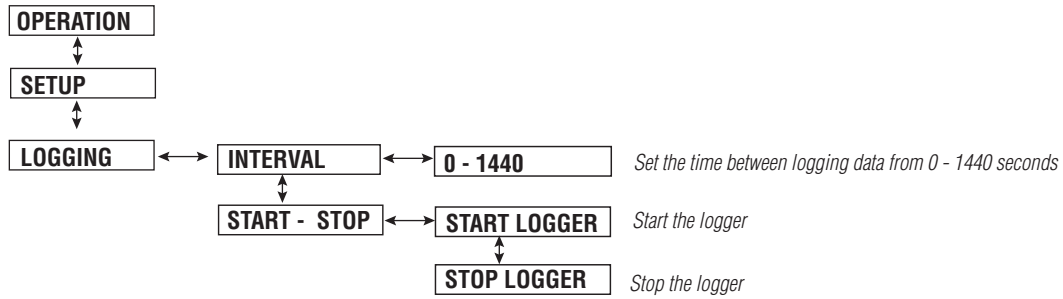

**** The iCIP controller clock should be set before starting the logger****

The logging module (series 200 or 400) must be plugged in to the iCIP controller before any logging parameters can be reached

iCIP Controller Menu Tree - Modbus RTU Communication Setup

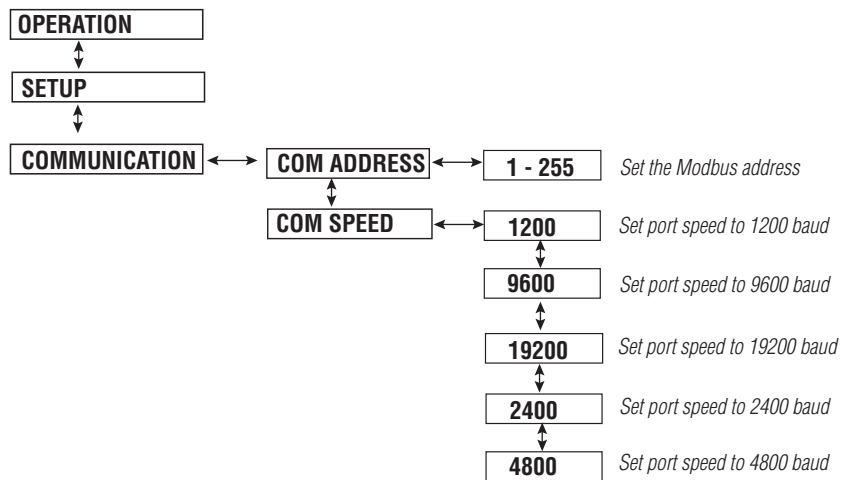

The Modbus module (series 300 or 400) must be plugged in to the iCIP controller before any Modbus parameters can be reached

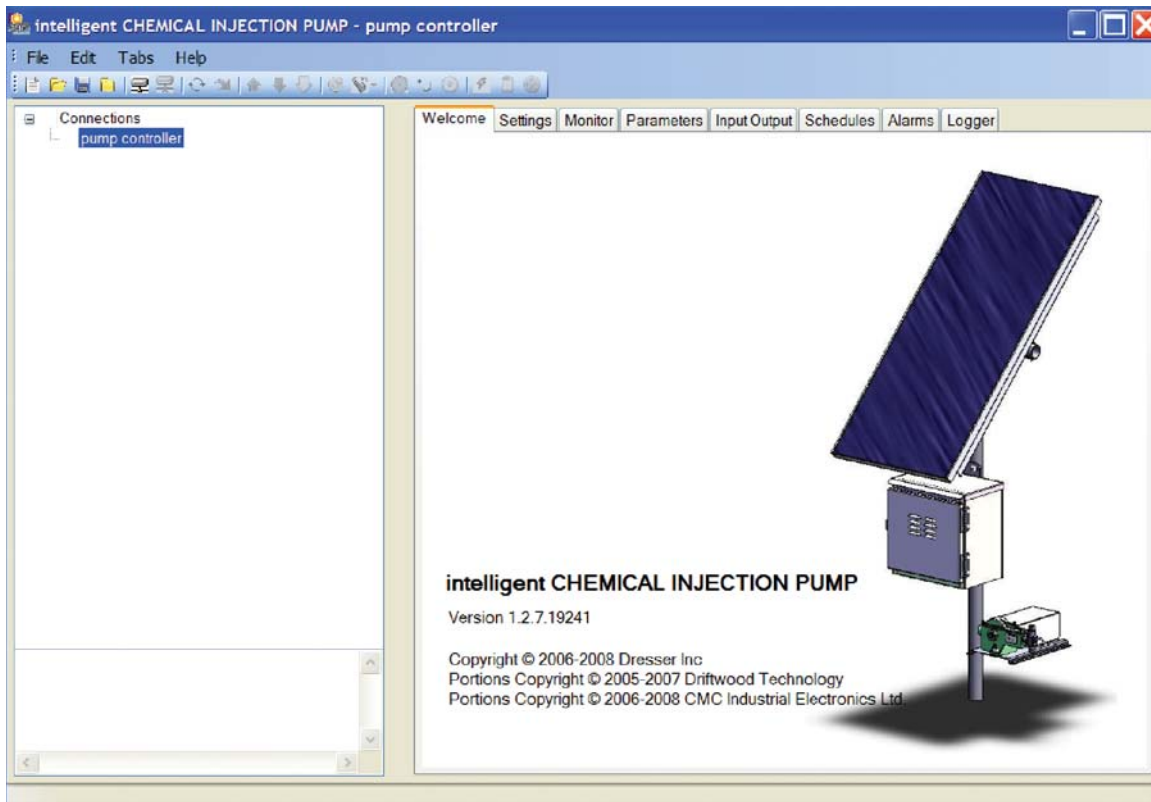

Figure 15 – Solar Pump User Terminal Software

Firmware Installation

An install/uninstall Firmware Upgrade Options module is required and will be provided with reference to product Solar Solutions Series installation Identification or serial number. This module will be available in the event of a firmware upgrade to the iCIP controller.

Upgrade Firmware on iCIP Controller

1. Insert Firmware Upgrade Options module into Options connector on front of iCIP controller.
 - a. The display should read Upgrade PGM.
2. Move the joystick to the right.
 - a. The display should read WAIT.
 - b. The display will next display the version of the firmware saved in the module.
3. Move the joystick to the right.
 - a. The display should read ARE YOU SURE.
4. To upgrade the firmware press the center of the joystick.
5. The display should read 1 then 2 and finally DONE.
6. Remove the Firmware Upgrade Option Module to complete the upgrade.

Motor Controller Enclosure

A covered NEMA rated enclosure housing has been provided to protect personnel from accidental exposure to electrical components and also provide a degree of protection to the electronics from the environment. Avoid static discharge into the circuitry when servicing or connecting electrical connections.

Solar Converters

These charge controllers use the latest in technology to further boost the performance current produced by the solar panels with the aid of micro processor solar power management tool. The result is a highly efficient solar power converter. When solar energy is being produced using solar panels, a microprocessor measures and determines the optimum operating charging point to charge the battery. A low voltage disconnect is included in the design to protect the battery from excessive discharge. Two LED's provide a visual indication as to the status of the controller. A temperature sensor is also provided to monitor battery temperature; this sensor provides feedback to the solar converter and will adjust battery charge conditions accordingly as the temperature changes.

Gel Cell Battery

All batteries conform to BCI specifications. Batteries are maintenance free. Sealed construction eliminates: periodic watering, corrosive spills and fumes. Electrolyte will not stratify, no equalization charging required. Allows for faster recharging intervals. Battery operating temperatures range from -76°F (-60°C) to 140°F (60°C). All batteries in multi-battery configurations are to be wired in parallel (connecting Positive to Positive and Negative to Negative). All batteries cables are equipped with a current limiting device to protect against an over current condition.

Simplex/Duplex/Triplex Pump

All pump heads have a standard 316 stainless steel body and incorporate the Texsteam proven plunger and packing design technology. Pump outputs are a basic setup input feature. The daily volume input requirement and the head size are all that is needed, simply "Set It and Forget It". Daily volumes can be entered in either SI (System International) Liters/Day or US customary units in Quarts/Day. Output volumes remain constant as pressure requirements change. Min/Max daily volumes based on continuous duty range from 1.75 to 552 quarts/day (1.66 to 522 Liters). Output pressures ranges up to maximum of 7000 PSI.

65 RPM ranges 2.9 to 798 quarts/day (2.8 to 755 liters)

Electric Motor

DC electric motors have gone through rigorous testing prior to distribution to market. The motors are designed for: high efficiency, low power consumption, long life, continuous duty cycle and maintenance free.

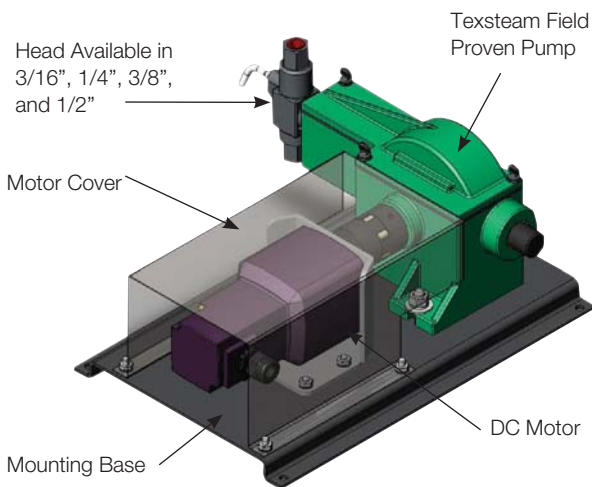

Figure 17 – Pump and Electric DC Motor Assembly

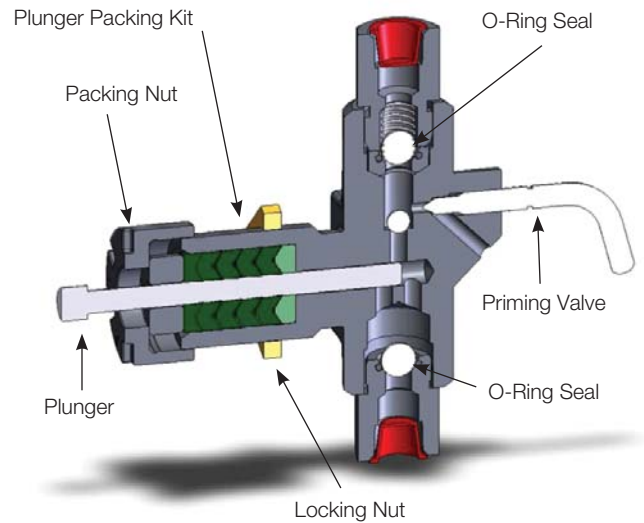

Figure 18 – Chemical Injection Pump Head

Elimination of Pump Drag and Friction Packing Tightness

Particular attention should be given to Packing Nut tightness. Over tightening of Packing Nut can result in excessive losses of electrical power, which effects battery life, and pre-mature seal packing degrading. The method for tightening all Texsteam pumps is the same. NEVER ADJUST PACKING WITH THE PUMP RUNNING. Loosen the Packing Nut until you can feel that it is free, then retighten until you feel a snug fit, then one more little tightening, the size of one (only) notch in the Packing Nut. If this does not work, stop the pump and tighten only one more notch.

Head Adjustment

Between 3 and 4 screw threads should be present once the locking nut to secure the head to the pump base has been tightened. Reference Figure 19.

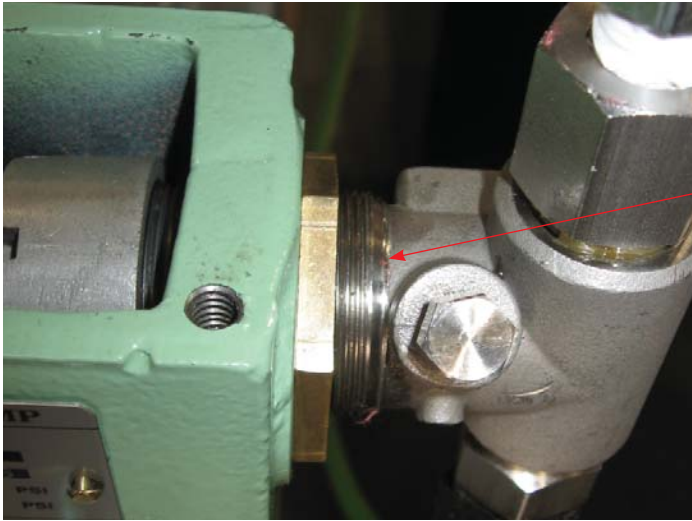

3 to 4 threads should be visible

Figure 19

An adjustment should be performed to minimize friction between the coupling and pump housing. Reference Figure 20.

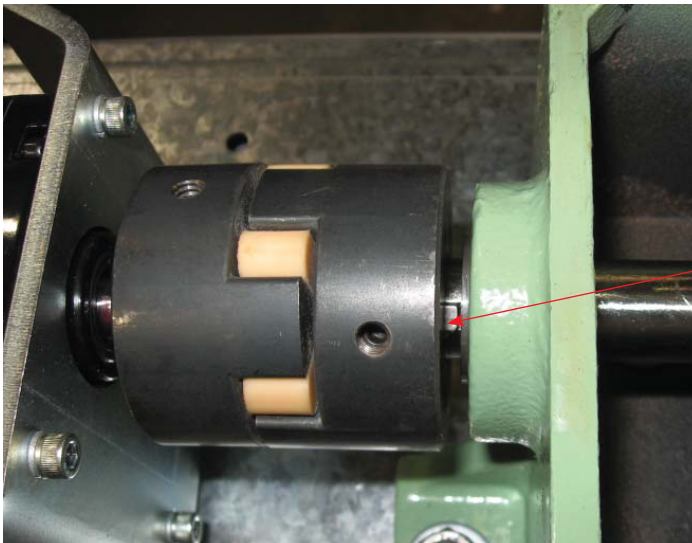

Adjust gap between coupling and bearing face to 1/16" or greater

Figure 20

ICIP Pump Setup Examples

Temperature Controlled Injection - Use of an alarm to control the start and stop of chemical injection based on the ambient temperature.

- Example based on a previously installed temperature probe and connected to Analog Input 1
- From the alarm menu select the following: (Reference menu trees)
 - ◆ Analog Input 1:
 - **Source:** Select "AIN 1"
 - **Comparison:** Select ">="
 - **Setpoint:** Enter desired temperature that pump will turn on and off
 - **Action:** Select "Change volume"
 - **Modifier:** Enter 0

Temperature Probe Setup - Setup of an analog temperature probe used to monitor ambient temperature.

Typical application: Monitoring of ambient temperature to trigger an event, ie. change volume or initiate a schedule.

- Example based on an installed Dresser temperature probe to Analog Input 1
- From the Analog Input menu select the following: (Reference menu trees)
 - ◆ Analog Input 1:
 - **Offset:** Enter
 - ❖ 757 for Fahrenheit scale
 - ❖ 800 for Centigrade scale
 - **Span:** Enter
 - ❖ 2725 for Fahrenheit scale
 - ❖ 1420 for Centigrade scale
 - **Averaging:** Enter 0

Low Volume Injection - Setup of a schedule to inject chemical at specific times of day or small volumes.

Typical application: Injection of volumes less than 1.75 quarts per day.

Example based on a required volume of one quart per day chemical injection utilizing a 3/16" head.

Consult your Dresser representative for other volumes requirements.

- From the Schedule Input menu select the following: (Reference menu trees)
 - ◆ Schedule 1:
 - **Source:** Select: "Schedule"
 - **Daily Volume:** Input: 2.92
 - **Start Minutes:** Input: 1
 - **Start Hours:** Input: 0
 - **Stop Minutes:** Input: 1
 - **Start Hours:** Input: 0
 - **Time On:** Input: 60
 - **Time Off:** Input: 2

- Select "Run Schedules" from the Operation menu

Logging Performance Data - Setup to log performance data at predetermined intervals.

Typical application: Series 200 unit. Log and review iCIP pump parameters and analyze trends.

Example based on a 20 minute time between logged data.

- iCIP pump must be equipped with a logging module.
- From the Logging Input menu select the following: (Reference menu trees)
 - ◆ Interval: Input 1200
 - ◆ Start - Stop: Select: "Start Logger"

Wiring Diagrams

Wiring diagrams provided with units when shipped. Consult Dresser if an additional or specific wiring diagram is needed.

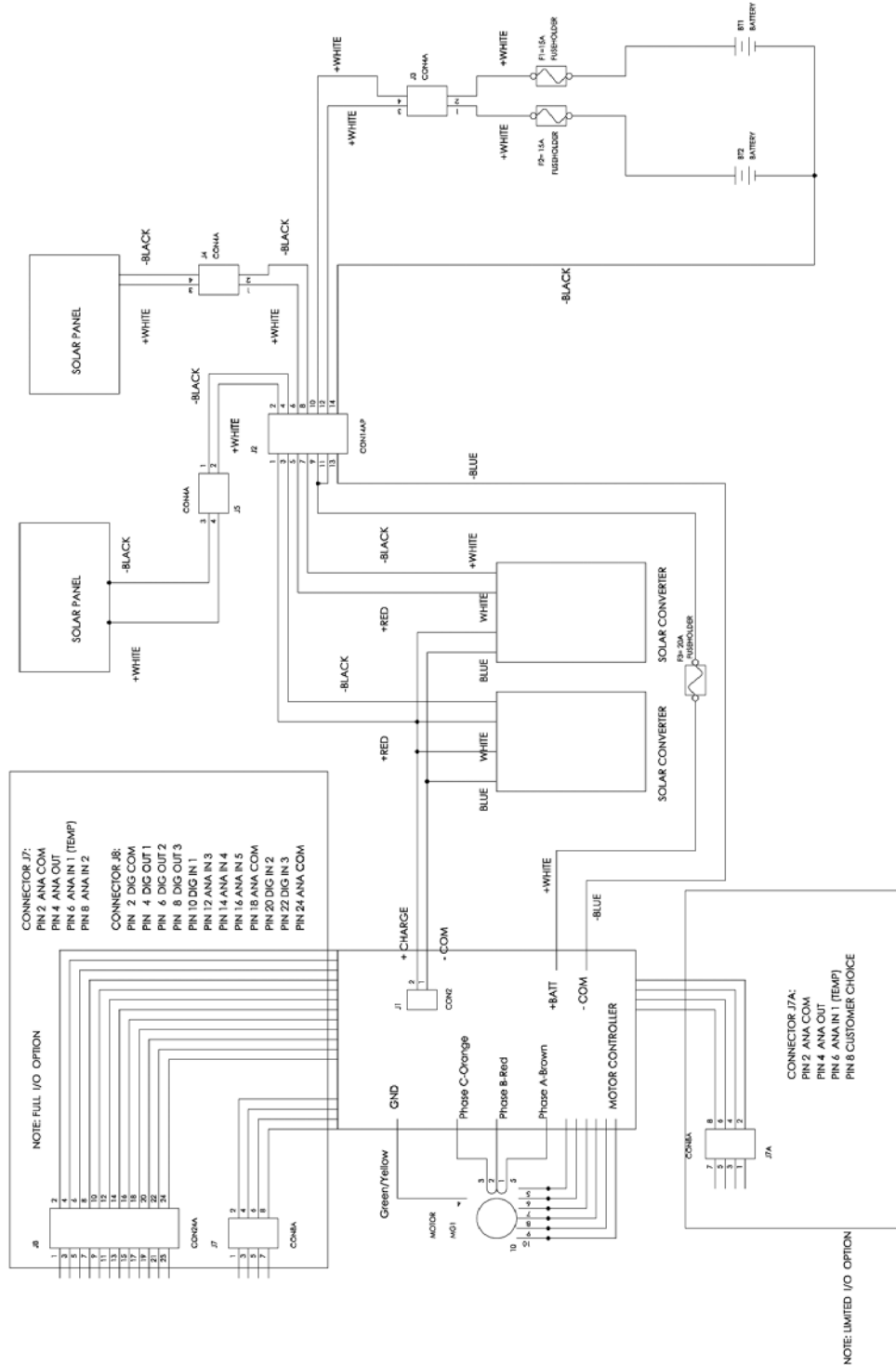

Servicing

WARNING

**EXPLOSION HAZARD -
SUBSTITUTION OF COMPONENTS MAY IMPAIR
SUITABILITY FOR CLASS 1, DIVISION 2.**

ADVERTISSEMENT

**- RISQUE D'EXPLOSION -
LA SUBSTITUTION DE COMPOSANTS PEUT
RENDRE CE MATERIEL INACCEPTABLE POUR LES
EMPLACEMENTS DE CLASSE 1, DIVISION 2.**

WARNING

**- EXPLOSION HAZARD -
DO NOT REPLACE ANY COMPONENT
UNLESS POWER HAS BEEN SWITCHED
OFF OR THE AREA
IS KNOWN TO BE NON-HAZARDOUS.**

ADVERTISSEMENT

**- RISQUE D'EXPLOSION -
COUPER LE COURANT OU S'ASSURER QUE
L'EMPLACEMENT EST DESIGNÉ NON DANGEREUX
AVANT DE REPLACER LE COMPOSANTS.**

WARNING

**- EXPLOSION HAZARD -
DO NOT DISCONNECT EQUIPMENT UNLESS
POWER HAS BEEN SWITCHED OFF OR THE AREA
IS KNOWN TO BE NON-HAZARDOUS.**

ADVERTISSEMENT

**- RISQUE D'EXPLOSION -
AVANT DE DECONNECTER L'EQUIPEMENT, COUPER
LE COURANT OU S'ASSURER QUE L'EMPLACEMENT
EST DESIGNÉ NON DANGEREUX.**

Emergency field repairs by authorized service technicians are strongly advisable. Repairs made by un-authorized technicians will void any warranty. To assure safety of equipment and personnel, only Dresser recommended replacement parts shall be installed. And above all, disconnect power from the iCIP® pump before servicing.

Damage to wiring and operating equipment may be avoided with careful reviewing the operating and installation procedures document by qualified personnel. At all times, operating safety of electrical equipment is imperative to avoid injury to personnel.

IMPORTANT

Read this instruction document with special attention to warnings, cautions and safety concerns. **FAILURE TO ADHERE TO THESE INSTRUCTIONS COULD RESULT IN SAFETY HAZARDS WHICH MAY RESULT INJURY TO PERSONNEL, MOTOR/ CONTROLLER DAMAGE OR OTHER ELECTRICAL EQUIPMENT.** Doubts or reservations with regards to installations or maintenance with reference to connecting your "Solar Powered" Chemical Injection Pump system should refer to the detailed sections supplied in this manual. For additional instruction, classification or assistance, contact an authorized Service Center.

WARNING

Avoid personnel injury involving equipment that is in motion. Always remove or disconnect power prior to service to the motor, motor controller, batteries, charge controller, solar panels.

About Dresser, Inc.

Dresser, Inc. is a leader in providing highly engineered infrastructure products for the global energy industry. The company has leading positions in a broad portfolio of products, including valves, actuators, meters, switches, regulators, piping products, natural gas-fueled engines, retail fuel dispensers and associated retail point-of-sale systems, and air and gas handling equipment. Leading brand names within the Dresser portfolio include Dresser Wayne® retail fueling systems, Waukesha® natural gas-fired engines, Masoneilan® control valves, Consolidated® pressure relief valves, and Roots® blowers. It has manufacturing and customer service facilities located strategically worldwide and a sales presence in more than 100 countries.

Dresser, Inc.

16240 Port Northwest Drive
Houston, Texas 77041-2645 USA
Ph: 832.590.2306 Fax: 713.849.2879
Toll Free Phone: 800.945.9898 Email: txtpumps@dresser.com
www.dresser.com/texsteampumps

