

Model 15LH, 15LHX, 16LH, 16LHX

Small Volume High Pressure Regulator for Pressure Reducing & Relief

Max. Inlet Pressure...6000 psi
 Outlet Pressure Ranges...(15LH & 16LH) 10-1000, 10-2000 psi
 Outlet Pressure Ranges...(15LHX & 16LHX) 10-1000, 10-2000, 10-3100 psi

General Specifications

Flow Media (15 Series) All Non-Toxic Gases
 (16 Series) Liquids & Gases
 Flow Capacity See Capacity Chart 125-K-5
 Operating Temperature Range -65°F to 165°F
 End Connections 1/4" FNPT & MS-33649-4*
 (other sizes & types available on special order)
 Handwheel Turns to Full Pressure 16 Turns Approx.
 Weight... 6 lbs

Material Specifications

All Metal Parts in flow stream 18/8 Stainless Steel
 Standard Diaphragm Material Mylar
 Standard Valve Material Nylon

Note: Model 16LH & 16LHX are for reducing service only (no relief system)

Model Number	Basic Fig. Number	Relief System	Max Inlet Pressure	Max CV
15LH	10929	YES	6000	0.06
16LH	11059	NO	6000	0.06
15LHX	10930	YES	6000	0.018
16LHX	11118	NO	6000	0.018

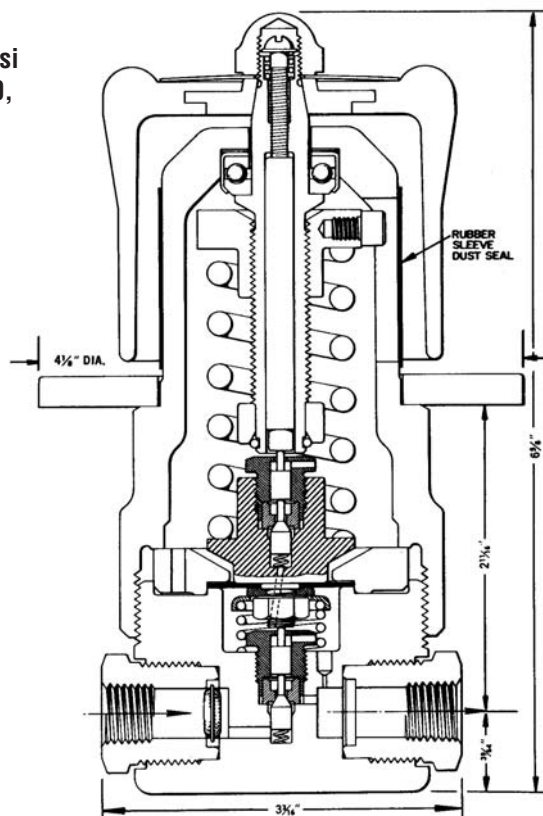

For mounting dimensions, see sheet W-15L-B01

Ordering Information

Select Basic Figure Number from Above table and complete the Figure Number by coding the desired output pressure range and end connections as in example below

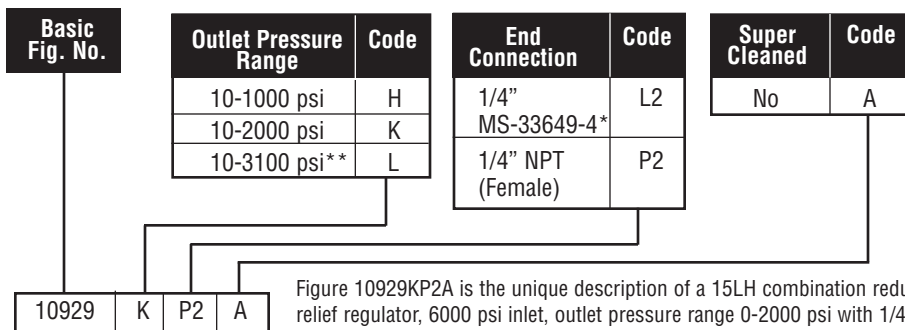

*Replaces AND-10050-04
 ** Available only in 15LHX & 16LHX models



RedQ

Dresser, Inc.

2822 S. 1030 W.
 Salt Lake City, Utah 84119
 Phone: 801.487.2225 Fax: 801.487.2587
 www.mooneycontrols.com

