



FLEXFLO® SURGE RELIEVER



The Fastest Response Time





Dresser Flexflo® Surge Reliever

Delivering the fastest response time of any surge reliever

For over fifty years, Flexflo Surge Relievers have been protecting the pipeline assets of global energy companies and those who use pipelines to transmit a wide variety of fluids. The reliability of this product is underscored by the reputation for quality inherent in the Dresser brand.

Dresser is able to shave milliseconds from response times because the Flexflo Surge Reliever has virtually no friction from its single elastomeric moving part. A single moving part is also your assurance of low maintenance costs and years of reliable service.

Anytime a change in liquid flow velocity in a pipeline occurs, a pressure surge develops. If left unchecked, this surge can cause extensive downstream damage.

A surge reliever can take the “kick” out of the flow in your pipeline and prevent costly damage and potential human harm. An unabated pipeline surge can render a tremendous amount of damage including: equipment loss, disruption of transmission business, pipeline integrity loss, transmission system lifespan reduction and the costly inspection of all equipment exposed to the overpressure event.

The Dresser Flexflo Surge Reliever is designed specifically with progressive and fast acting opening and controlled closing characteristics for surge relief. Every millisecond of delay equates to tremendous loss when a surge hits. The Flexflo Surge Reliever is your assurance of the best protection available.

Dresser Flexflo® Surge Reliever

Specifications

Body Materials: Carbon Steel

Available Sizes: 4" (101.6 mm)
6" (152.4 mm)
8" (203.2 mm)
12" (304.8 mm)

End Connections: Raised Face Flange
150, 300, 600 ANSI

Capacity: 161 C_v – 1,720 C_v

Working Temperature: -20°F - 150°F
(-29°C – 66°C)
common usage*

Max. Operating Differential: 1200 psig*

Max. Inlet Pressure: 1480 psig

Outlet Pressure Range: Up to 1480 psig

* Limited by Flexflo® Tube Selection.



Figure 1 - Flexflo® Surge Reliever

Features

- Single moving part, the tube, reduces number of failure modes compared to other surge valves
- Virtually instantaneous reaction on inlet pressure rise time to achieve full flow capacity in less than 200 milliseconds
- Ability to achieve bubble tight seal even when foreign matter may be present in the line
- Simple set point adjustment (simply increase or decrease nitrogen pressure).
- Elastomers available for numerous service conditions.
- Easy to maintain.
- Service temperatures to -40 degrees Fahrenheit
- Can relieve minor surges without any fluid flow

The Flexflo® Surge Reliever is designed to protect pipelines from excessive pressure surges in liquid applications. Flexflo® Surge Relievers are typically installed near loading terminals, pump stations and tank farms. Flexflo® Surge Relievers feature quick opening times in the low millisecond range to provide unsurpassed protection of your pipelines against pressure surge. Rugged Flexflo® Surge Relievers are available in 4" (101.6 mm) to 12" (304.8 mm) bore. The Flexflo® Surge Reliever typically is used with a Model 888 bottle assembly. Consult Dresser for more details.

Fabricated Construction

The Flexflo® Surge Reliever is composed of a slotted core (1) over which a synthetic rubber expansible tube (2) is stretched. Surrounding the tube is the liner (8) which limits the expansion of the tube. A set of slots in the liner provides a path for rapid flow of gas between the jacket space (9) and the larger annular body cavity (10) between the liner and the body (3). The set pressure is established by pressurizing the body cavity with inert gas (normally nitrogen). While the inlet pressure is below the set pressure, the valve remains closed bubble-tight. When line pressure exceeds the set pressure, the inlet pressure expands the tube, and flow occurs through the inlet and outlet core slots. Opening is achieved in milliseconds to relieve a surge, and, as the surge pressure subsides below the set pressure, the Flexflo will again shut-off bubble tight.

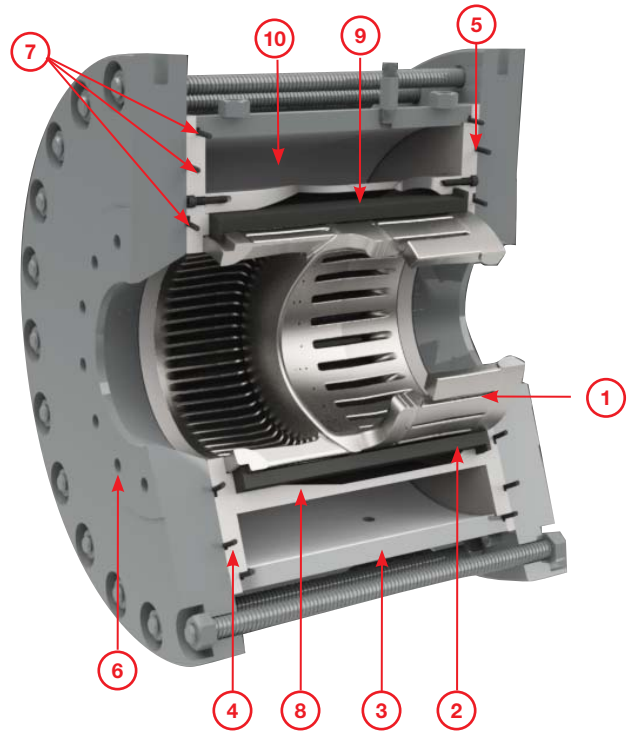

Figure 2 - Exploded View



Figure 3 - The Flexflo® flanges have been jacked apart approximately 1/8" by using the inside nuts. The entire body section is then lifted out of the line. The cover plate is removed from the outlet end of the body, by removing the cap screws. The core and tube then can be pulled out of the body.

Basic Liquid Sizing Equation

for preliminary sizing estimates for the
Flexflo Surge Relief Valve

Surge Reliever Sizing Equation

$$Q = F_f \sqrt{\frac{(P_{set} - P_{back})}{SG}}$$

Where:

Q = Flow Rate (gpm)

F_f = Flow factor corresponding to the partial open factor of the valve under a given set of conditions. This factor is directly related to the differential pressure between that of the inlet and jacket pressure of the surge reliever

P_{set} = Pressure at which flow through the relief valve begins (psig)

P_{back} = Maximum expected back pressure (psig)

SG = Specific gravity of liquid

$$\%OP = \frac{F_f}{C_s}$$

%OP = Percent above set pressure sufficient to achieve the required flow

C_s = Slope of the valves performance curve

$$P_{max} = P_{set} * \left[\frac{\%OP}{100} \right]$$

P_{max} = Maximum expected line pressure during surge event for the selected valve.

Table 1 - Flexflo® Surge Reliever Flow Coefficients

Valve Size	Class	Performance Curve Slope (C _s) (gsm)	Maximum Flow Factor (C _v) (gpm)
4	150/300	2.42	240
	600	1.46	161
6	150/300	4.84	479
	600	3.21	352
8	150/300	8.59	850
	600	6.67	731
10	150/300	11.9	1177
	600	8.25	905
12	150/300	17.39	1720
	600	11.94	1309

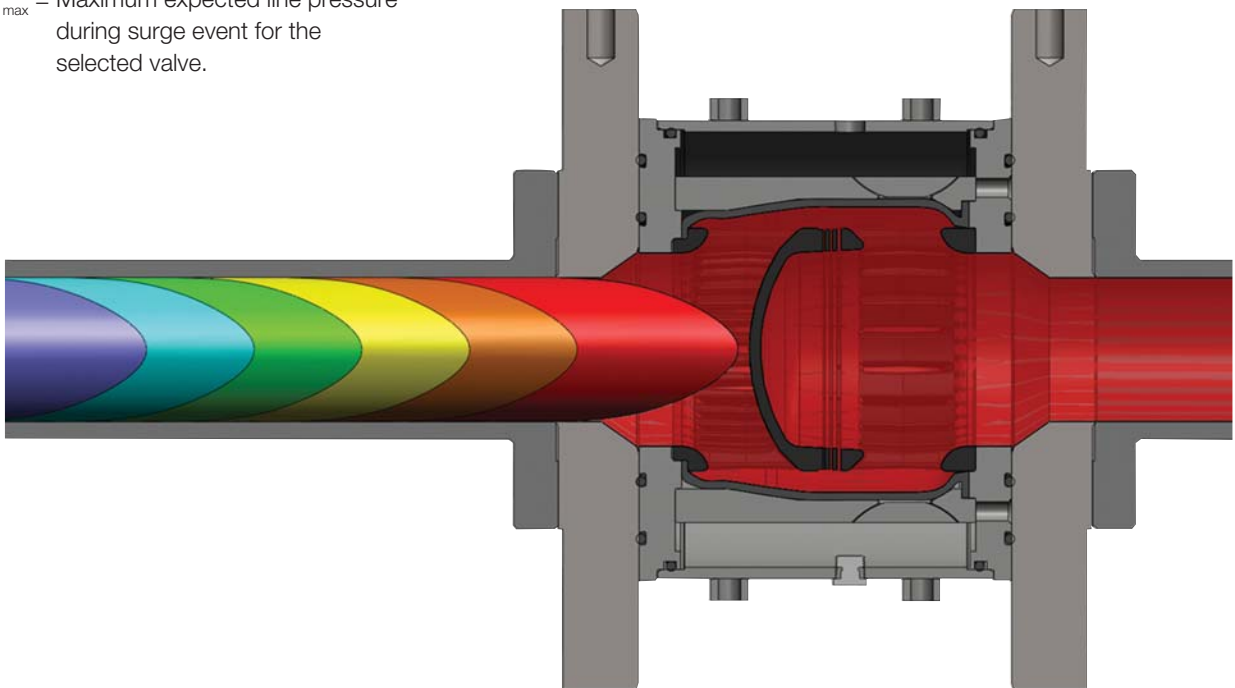

Table 2 - Flexflo® Surge Reliever Overall Dimensions and Weights

Class 150														
Size Inches	A		K		C		D		E		F		Weight	
	Inches	(mm)	Inches	(mm)	Inches	(mm)	Inches	(mm)	Inches	(mm)	Inches	(mm)	Lbs.	(Kg.)
4	14.87	(378)	2.31	(59)	18.37	(467)	4.00	(102)	0.06	(2)	6.31	(160)	500	(227)
6	18.12	(460)	2.12	(54)	23.62	(600)	6.00	(152)	0.06	(2)	8.12	(206)	902	(409)
8	21.15	(537)	2.12	(54)	28.12	(714)	8.00	(203)	0.06	(2)	8.12	(206)	1433	(650)
10	24.75	(629)	2.31	(59)	31.50	(800)	10.00	(254)	0.19	(5)	8.50	(216)	1872	(850)
12	28.75	(730)	2.5	(64)	38.62	(981)	12.00	(305)	0.19	(5)	10.50	(267)	3373	(1530)

Class 300														
Size Inches	A		K		C		D		E		F		Weight	
	Inches	(mm)	Inches	(mm)	Inches	(mm)	Inches	(mm)	Inches	(mm)	Inches	(mm)	Lbs.	(Kg.)
4	15.0	(381)	2.31	(59)	19.00	(483)	4.00	(102)	0.06	(2)	7.00	(178)	600	(272)
6	19.12	(486)	2.50	(64)	24.37	(619)	6.00	(152)	0.06	(2)	8.50	(216)	1153	(523)
8	23.50	(597)	3.00	(76)	29.25	(743)	8.00	(203)	0.06	(2)	9.00	(229)	1854	(841)
10	27.62	(702)	3.75	(95)	33.37	(848)	10.00	(254)	0.19	(5)	9.75	(248)	3837	(1744)
12	31.37	(797)	3.81	(97)	38.62	(981)	12.00	(305)	0.19	(5)	11.81	(300)	4189	(1900)

Class 600														
Size Inches	A		K		C		D		E		F		Weight	
	Inches	(mm)	Inches	(mm)	Inches	(mm)	Inches	(mm)	Inches	(mm)	Inches	(mm)	Lbs.	(Kg.)
4	16.94	(430)	3.13	(80)	20.13	(511)	4.00	(102)	0.25	(6)	7.62	(194)	750	(340)
6	22.12	(562)	3.75	(95)	26.37	(670)	6.00	(152)	0.25	(6)	9.75	(248)	1905	(864)
8	26.75	(679)	4.62	(117)	29.87	(759)	8.00	(203)	0.25	(6)	10.62	(270)	2646	(1200)
10	29.62	(752)	4.38	(111)	34.87	(886)	10.00	(254)	0.38	(10)	10.81	(275)	4150	(1885)
12	35.12	(892)	5.75	(146)	41	(1041)	12.00	(305)	0.38	(10)	13.75	(349)	6393	(2900)

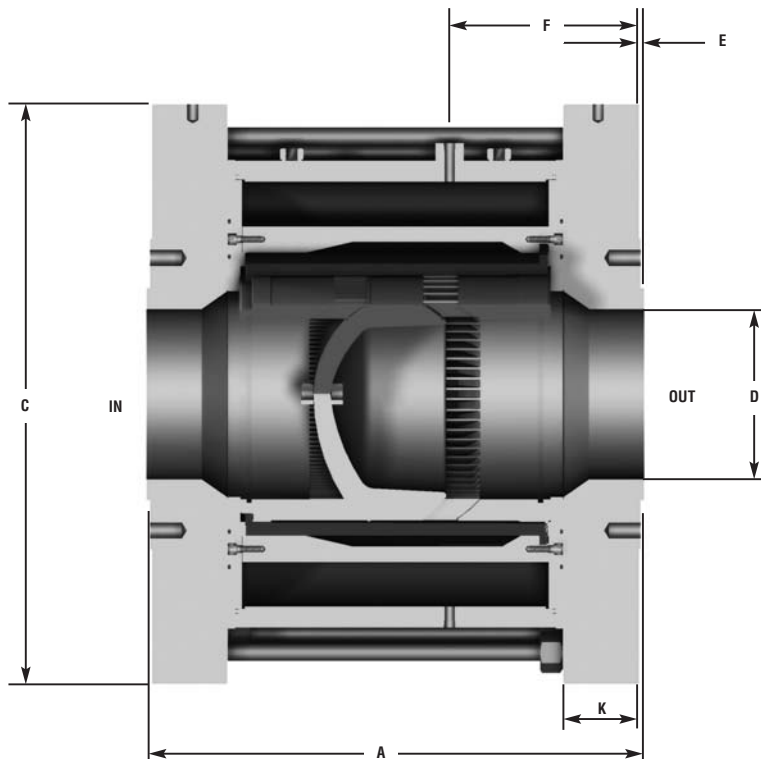
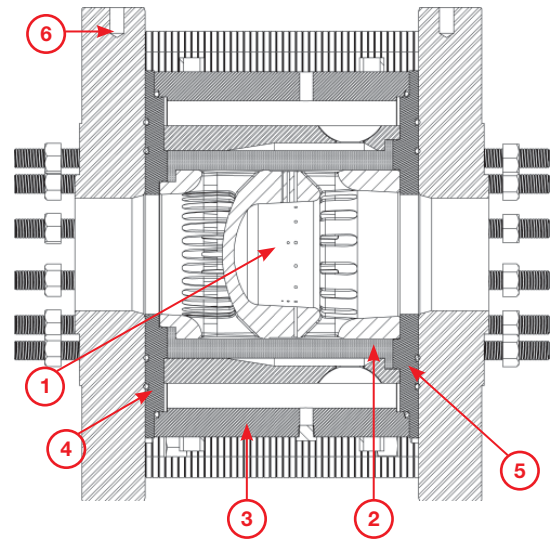

Table 3 - Flexflo® Surge Reliever Standard Materials

Part	Low Pressure	Medium Pressure	High Pressure
1. Core	Ductile Iron ¹	Ductile Iron ¹	Steel or Ductile Iron ¹
2. Tube	Nitrile	Nitrile	Nitrile
3. Body Sleeve	Steel ²	Steel ³	Steel ³
4. Cover Plate (Inlet)	Steel	Steel	Steel
5. Cover Plate (Outlet)	Steel ⁴	Steel ⁴	Steel ⁵
6. Line Flanges	Steel	Steel	Steel
7. O-Rings	Nitrile or Fluorocarbon	Nitrile or Fluorocarbon	Nitrile or Fluorocarbon

- ¹ Electroless Nickel plated .003" to .0035" for enhanced corrosion protection. Steel fabricated core only available for class 600 8", 10" and 12" sizes.
- ² 12" size standard piping material is ASTM A350 LF2 or LF3 forged pipe. All other sizes utilize A106grade C seamless pipe as the standard material of construction.
- ³ 12" and 10" sizes utilize ASTM A350 LF2 or LF3 forged plate as the standard material for construction.
The standard plate material of construction for all remaining sizes is ASTM A516 Grade 70 plate.
- ⁴ ASTM A516 grade 70 plate is the standard material of construction.
- ⁵ ASTM A350 LF2 or LF3 forged plate is the standard material of construction.
- * Other material options available, consult Dresser representative for information and availability.



Flexflo® Surge Reliever Coding

SR4-1-1832-1-814

Example: SR4-1-1832-1-814

4" class 150 w/standard industrial paint exterior, FB Epoxy wetted internals, A105 pipe, and A516 plate construction materials, standard quality documentation, 814 nitrile tube.

Size Code (in.)	Class Code	Descrip.	External Coating Code	Descrip.	Internal Coating Code	Descrip.	Pipe Material Code*	Descrip. (ASTM#)	Plate Material Code*	Description	Qty. Code**	Descrip. (ASTM#)	Standard Elastomers***
4	1	ANSI 150	0	No Coating	0	No Coating	1	A106 Grade C	1	A516 Plate	1	Standard Document Set	846 Nitrile (1440 max differential pressure)
6	3	ANSI 300	1	Standard Industrial Coating	7	Phenotic	2	A350 LF2 or LF3 Forged Pipe	2	A350 LF2 or LF3 Forged Plate	2	Cold weather specif.	
10	6	ANSI 600	2	Marine Grade Coating	8	Fusion Bond Epoxy	3	A105 Forged Pipe	3	A105 Forged Plate	3	NACE specif.	814 Nitrile (740 psig maximum differential)
12			3	Low VOC Marine Coating	9	Rilsan			4	A537 (recomended service temps below -20°)	4	Customer specif.	
			4	Misc									

* For more information reference Table 3: Flexflo Surge Reliever Standard Materials. For additional material options please consult a Dresser representative for more information.
 ** Contact a Dresser representative for a detailed explanation of quality options and documentation.
 *** Only the standard Nitrile elastomer is listed here. Please reference the Flexflo Tube Material chart on page 7 for an expanded list of available compounds for various service conditions and chemical compatibilities. Not all materials available in all classes.

Standard Flexflo® Tube Materials

Material (Code Number)	814 (C)	846 (E)	878 (A)	893 (D)	888 (B)	725 (F)	745 (M) 744 (L) 740 (K)	732 (H)	644 (R)
Base Polymer	Nitrile (std)	Nitrile (std)	Hydrin	Hydrin	Ethlene Propylene Diene Monomer	Hydrin	Tomac HNBR	Flourel	Nitrile
Max. Differential (psid)	740	1480	740	285	740	60	745 - 285, 744 - 740 740 - 1480	740	1480
Temp. Range min/max F	+10/+150	+10/+150	-20/+150	-40/+150	-20/+175	-40/+120	+10/+212	+32/+120	-40/+150
Fluid Compatability									
Hydrocarbon									
Gaseous	OK	OK	OK	OK	NR	OK	OK	OK	OK
Liquid	OK	OK	OK	OK	NR	OK	OK	OK	OK
% Aromatic content Max	20	15	30	15	0	20	40	100	0
Max sulfur % wt	0.5	0.5	5	0.5	0	5	5	15	0
Water	OK	OK	NR	NR	OK	NR	OK	OK	OK
Nitrogen	OK	OK	OK	OK	OK	OK	OK	OK	OK
Air	OK	OK	OK	120 F max	OK	OK	OK	OK	OK
Synthetic Lubes (Phosphate Esters)	NR	NR	NR	OK	NR	NR	Limited	NR	NR
Peroxides (Sour Gasoline)	NR	NR	NR	NR	NR	NR	OK	OK	OK
Ketones/Animes	NR	NR	NR	NR	NR	NR	NR	NR	NR
Max H ₂ S in water % wt	0.5	0.5	na	na	Unlimited	na	1.5	5	na
Methl. Ethyl Alcohols	NR	NR	NR	OK	NR	NR	OK	NR	NR
Nominal Durometer	65+	75	50	70	75	30	65, 75, 85	75	75
	Gen-Hydro-carbon Service. Water	Gen-Hydro-carbon Service. Water	Gen-Hydro-carbon Service. Water at Lower-Temps.	Not recommended above ANSI 150	Recommended Std. Water, Ammonia, Service Material at Lower Temps.	Low P Applications Only	Crude Oil- White Petrol Products, Especially Unleaded Gas w/ Alcohols, Ethers	Hot Fluid Resistance Fuels, Oils NR for Ketones, Steam, Alcohols	Gen-Hydro-carbon Service, Water

NOTES:

OK Indicates Material is Compatible with Corresponding Fluid.

NR Indicates Material Not Recommended for Specific Flexflo® Regulator Model.

Contact your local representative or factory for application drawings special applications or more detailed information.

Capacity Boosting and Nitrogen Control Panels

In applications where the allowable rise above set pressure is small, the required number of surge relievers required for the applications can become excessive. The surge reliever flow capacity is proportional to the percent rise above set pressure. Thus if the allowable rise above set pressure is small, the surge reliever is only operating at a fraction of its full flow capacity. It can be more economical in some applications to use a capacity boosting control panel to utilize the maximum C_v of a surge reliever. The control panel is connected to the surge reliever and the pipeline. When excessive pressure is sensed by the control panel, the surge reliever jacket pressure is vented, allowing the surge reliever to fully open. When the surge has passed the system repressurizes, resetting the system at the original set pressure. When sizing your surge reliever, Dresser engineering will analyze your application and advise you if this capacity boosting control panel is a recommended option.

Currently 3 standard panels are offered.

CP1 – Nitrogen Control Panel for Control of a Single Valve

The most basic panel is the CP1 Nitrogen control panel. This panel supplies nitrogen to the jacket of the surge reliever at the correct set pressure for the particular application. The Dresser 15L Handloader reduces the nitrogen supply pressure to the correct set pressure and includes an integral relief to ensure that temperature changes will not affect the set pressure of the surge reliever.



CB – Capacity Boosting Panel

The CB panel is the most basic of the capacity boosting panels and allows for the maximum flow the valve is capable of over a minimum of pressure differential.



CBAT - Capacity Boosting, Alarm, and Test panel

The CBAT panel is identical in operation to the CB panel with the addition of a low pressure switch for signaling when the high pressure nitrogen supply is low. Also included is an additional Dresser Handloader that is intended to be piped upstream of the surge reliever and below an isolating valve in the line. Upon opening the test loop valve regulated nitrogen will be piped into the line allowing for a functional test of the reliever and capacity boosting panel.

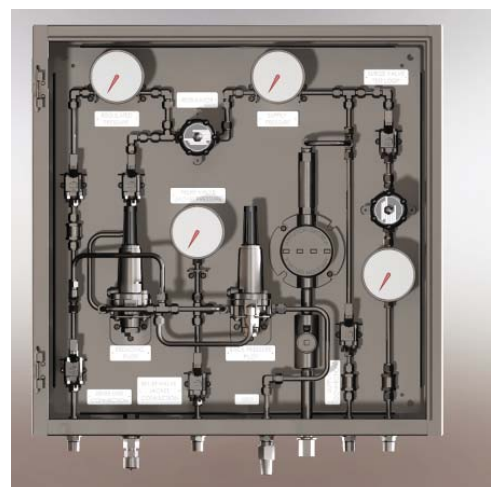

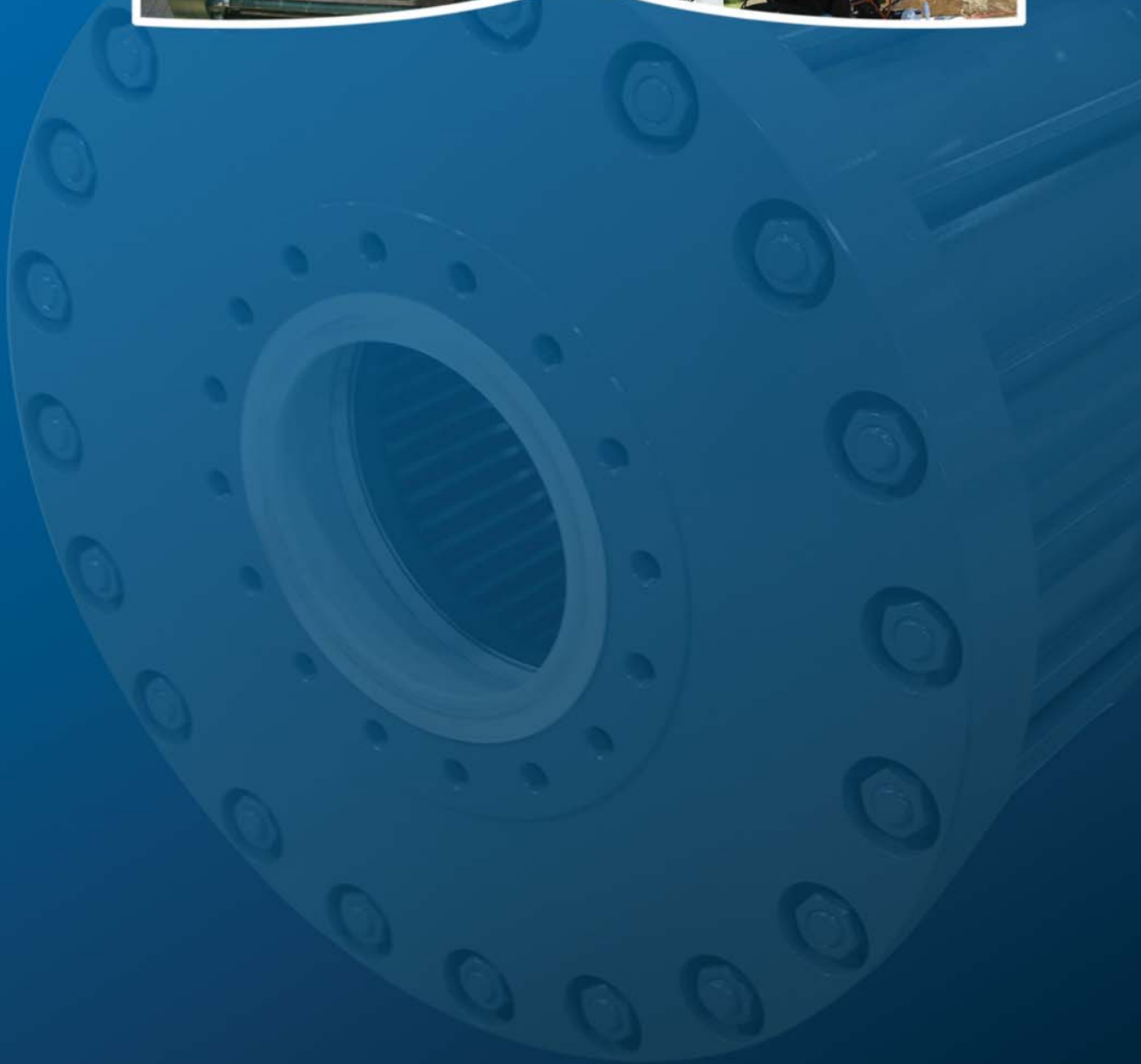

About Dresser® Products

Dresser brand products are highly engineered, technically superior and are designed to help global customers meet and exceed requirements for mission critical energy applications.

About Dresser, Inc.

Dresser, Inc. is a leader in providing highly engineered infrastructure products for the global energy industry. The company has leading positions in a broad portfolio of products, including valves, actuators, meters, switches, regulators, piping products, natural gas-fueled engines, retail fuel dispensers and associated retail point-of-sale systems, and air and gas handling equipment. Leading brand names within the Dresser portfolio include Dresser Wayne® retail fueling systems, Waukesha® natural gas-fired engines, Masoneilan® control valves, Consolidated® pressure relief valves, and Roots® blowers. It has manufacturing and customer service facilities located strategically worldwide and a sales presence in more than 100 countries.

The information presented in this brochure is for informational purposes only.

For actual design assistance please visit our website at www.dresser.com/redq or see your local representative.

Dresser, Inc.

2822 S. 1030 W.

Salt Lake City, Utah 84119

Phone: 801.487.2225 Fax: 801.487.2587

www.dresser.com/redq



© 2009 Dresser, Inc.

Flexflo is a registered trademark of Dresser, Inc.

www.dresser.com

Flexflo® Surge Reliever

3.10