



Model 400, Forged Body Design Powreactor Dome Regulator

OPERATION AND MAINTENANCE

Contents

Scope	1	Adjustment	2
General Description	1	Maintenance	3
Installation	2	Appendix	8

NOTE: The following drawings form a part of this Instruction:

Assembly Drawing:	As Applicable per Appendix
Parts List:	As Applicable per Appendix
Mounting Dimension Drawing:	As Applicable per Appendix
Special Tool Drawing:	As Applicable per Table 1

Scope

These instructions cover installation, adjustment, and service of the following basic models of RedQ Powreactor Air Dome Regulator:

400 MODEL	VALVE TYPE	DOMES PLATE	LOADING OPTION	EXT SENSE
402E	Unbal.	Non	Ext. or	No
412E	Bal.	Removable	Int.	
401F	Unbal.	Removable	Int.	Yes
411F	Bal.			
402F	Unbal.	Removable	Ext. or	Yes
412F	Bal.		Int.	

General Description

(Refer to applicable Assembly Drawing)

The RedQ Powreactor pressure reducing regulator is designed to maintain a constant delivered pressure in a line or in a closed vessel where inlet pressure or volume of flow may vary.

It is a balanced pressure type of regulator, which is actuated by static gas pressure in a sealed dome. There

is a flexible diaphragm between the sealed dome and the outlet line fluid. Downstream fluid pressure is transmitted directly to the under side of the diaphragm through an internal sensing port. When desired, this port can be plugged and a remote sensing line can be used.

When outlet line pressure drops below dome pressure, the diaphragm moves out slightly and pushes the main valve open. This allows inlet line fluid to flow through the valve until outlet line pressure builds up enough to balance the dome pressure. Then the diaphragm moves back to throttle or close the main valve so that dome and outlet pressure always remain in balance.

Any change in dome pressure causes a corresponding change in outlet line pressure. When the dome is completely vented, the main valve shuts off bubble tight.

RedQ Powreactors may be used in either gas or liquid systems, but the dome must always be loaded with air or other gas.

Powreactor models with unbalanced valves will show a slight variation in delivered fluid pressure if the inlet pressure varies over a wide range after the dome is set. Small changes of inlet pressure have no appreciable effect. Balanced valves are provided in order to minimize this variation.

Installation

A. Sensing Connection

Powreactors are normally shipped with plugs arranged for internal sensing of downstream pressure. If external sensing is desired, prepare regulator as follows:

1. Remove dome and diaphragm as directed in Maintenance -C.-5.,
2. Insert plug in body internal sensing port and reassemble dome parts.
3. Remove plug and o-ring from body external sensing port.
4. Connect external sensing line from this port to the downstream line at the point where pressure response is desired, using the correct connection type and size. Sensing line should be as large as practicable, 3/8" O.D. tube minimum.

B. Regulator Mounting

(Refer to installation diagrams, Figures 1 and 2, and the applicable mounting dimension drawing.)

Note that downstream pressure gage should be readable from dome loading controls. Installation of the RedQ Powreactor in a horizontal line with the dome uppermost is recommended.

Before mounting regulator, make certain line is free from foreign particles that could damage regulator valve seat.

Replacement of trim parts is accomplished by removal of body plug; sufficient clearance should be provided to allow this.

On models with screwed end connections, special studs and nuts are provided for mounting, as shown on mounting drawings.

CAUTION:

Do not clamp on body plug when installing end connections.

C. Dome Connection

1. Externally loaded – Connect dome to a source of gas at a pressure higher than the desired regulated downstream pressure, through a suitable dome loading control device such as RedQ small volume reducing and relief regulator (hand loader Since the dome is sealed after loading, a change in

temperature will cause a slight change in dome pressure, with a corresponding shift in outlet line pressure. This outlet pressure shift amounts to about 1% for each five-Fahrenheit degrees. When the RedQ Hand Loader is used to load the dome, dome pressure is maintained constant regardless of ambient temperature change.

2. Internally loaded – Dome loading needle valves are incorporated into the regulator, and gas from the inlet line is used to load the dome.

CAUTION:

The internal loading feature can be used only where the line fluid is gas.

Adjustment

The only adjustment required to put the RedQ Powreactor Regulator in operation after it has been installed, is to load the dome with a gas pressure, which will result in the desired outlet pressure.

Note: Actual pressure inside the air dome will be slightly higher than the controlled outlet pressure.

A. ADJUSTMENT, INTERNALLY LOADED MODELS (Models 402F, 412F)

1. Using loading wrench per Table I (Sheet 12), close body needle valve, and vent dome by opening dome plate needle valve.
2. Close dome plate needled valve.
3. Open inlet stop valve, admitting pressure to inlet side of regulator, and adjust outlet stop valve to allow a small flow.
4. Open body needle valve about one-half turn. This opens loading duct to inlet line.
5. Insert loading wrench in dome plate needle valve and open slowly, watching outlet pressure gage as it indicates pressure being established in the outlet line.
6. When the desired outlet pressure is reached in the line, as shown on the outlet pressure gage, close dome plate needle valve.
7. Close body needle valve. (Do not exceed 30 inch-lb torque on these loading needle valves – see Table I.)
8. Check to see that both needle valves are snugly closed and then open outlet stop valve gradually to wide open position.

Internally loaded Powreactor is now in operation.

B. ADJUSTMENT, EXTERNALLY LOADED MODELS (Models 401F, 411F)

1. Adjustment procedure using RedQ Hand Loader:
 - a. Turn Loader handwheel counterclockwise to its limit. This vents the dome.
 - b. Admit line pressure to inlet port of Powreactor and adjust outlet stop valve to allow a small flow.
 - c. Slowly turn loader handwheel clockwise until outlet pressure gage shows desired pressure in the outlet line.
 - d. Slowly open outlet stop valve to wide open position.

No other adjustment is necessary, and any temperature variation will be automatically compensated.

2. Adjustment procedure using loading manifold or other devices preferred by the user.
 - a. Close dome loading line and vent dome.
 - b. Admit line pressure to inlet port of Powreactor and adjust outlet stop valve to allow small flow to outlet line.
 - c. Admit gas pressure to dome loading line.
 - d. Slowly open dome loading line, watching outlet pressure gage as it indicates pressure being established in the outlet line.
 - e. When the desired outlet pressure is reached in the outlet line, as shown on the outlet pressure gage, close dome loading line.
 - f. Slowly open outlet stop valve to wide open position.

External loaded Powreactor is now in operation.

Maintenance

(Refer to Assembly Drawing to identify parts.)

If outlet pressure deviates from original setting, correct as follows:

A. RISE IN INLET PRESSURE

1. Check to see whether inlet pressure has fallen below level it was when dome was set. Outlet will return to original setting when inlet rises to original level. If inlet is expected to remain at the lower level, reset dome pressure per Adjustment Section.

2. Check temperature. A rise in temperature will cause a rise in outlet pressure. Outlet will return to original setting when temperature returns to original level. (See Installation -C.-1.)
3. Check for dirt in valve and regulating mechanism:
 - a. Slowly open outlet line so as to increase flow through the regulator.
 - b. Slowly return to normal flow.
 - c. Outlet gage should show return to original setting.
4. If regulator is externally loaded, check loading mechanism for malfunction.
5. If outlet continues to rise, check for possible leakage of main Powreactor valve. Follow directions for disassembly, Maintenance -C.-4.

A. DROP IN OUTLET PRESSURE

1. Check to see whether inlet has raised above the level it was when dome was set. Outlet will return to original setting when inlet returns to original level. If inlet is expected to remain at the higher level, reset dome pressure per Adjustment
2. Check temperature. A drop in temperature will cause a drop in outlet pressure. Outlet will return to original setting when temperature returns to original level. (See Installation-C.-1.)
3. Check for leak in dome venting system:
 - a. On internally loaded models, use bubble fluid on dome plate and body needle valve.
 - b. On externally loaded models, use bubble fluid on vent valve of the loading device.
 - c. On all models use bubble fluid around inlet face between dome, dome plate (if any), and body.
 - d. If leaks appear, vent dome, inspect vent valves and replace if necessary.
 - e. Reset dome to get proper outlet pressure, per Adjustment.
 - f. If leaks appear around interfaces between dome and dome plate (if any), or body, close inlet stop valve and inspect dome seals for damage. Follow directions for disassembly Section C1-C3 and C5.

C. Replacement of parts

Order spare and replacement parts by part number and name, as shown on the applicable Assembly Drawing and Parts List; or give serial number of the regulator involved and names of parts required.

To replace damaged parts, the Powreactor Regulator need not be removed from the line, but inlet and outlet stop valves must be closed tightly, and pressure released from dome and line.

Disassembly procedure is similar for all Model 400F regulators, but wrench sizes, special tools, and assembly torques may differ. Refer to Table I to find the data that applies. Refer to Assembly Drawing for identification of parts.

1. Close inlet stop valve. This traps pressure on inlet side of regulator.
2. Open outlet blowdown valve (if any) or leave outlet stop open, so that trapped inlet pressure will be vented and all pressure released from Powreactor body.
3. Vent dome as follows:
 - a. On internally loaded Powreactors, open dome plate needle valve, using wrench per Table I.
 - b. On external loaded Powreactors using other loading devices, release gas pressure from device, open dome vent valve, and then remove loading device from dome port.
4. Disassemble Powreactor valve as follows:
 - a. With all pressure vented from Powreactor, remove body plug unit, using hex wrench per Table I. This allows valve and spring to drop clear. With balanced valve, separate pushrod will also drop out.
 - b. Remove valve seat bushing, using special bushing wrench per Table I. This frees valve seat and gasket.
 - c. If valve seat does not fall out freely, use a wood or brass rod to work it loose.
 - d. Disassemble soft seal valve seat unit for inspection. Parts may be pried apart with a thin blade, but be careful not to damage parts.
 - e. If valve is standard construction, valve and spring will fall freely out of body plug.
 - f. If valve is balanced type, disassemble body plug unit as follows:
 - i. Remove valve and spring.
 - ii. Remove seal retainer, seal o-ring and seal, using care not to damage parts.
 - g. Do not remove gasket from body plug groove unless it is to be replaced. Gasket may be daaged by removal.
 - h. Valve guide in body plate does not normally need replacement, but can be removed by using wrench per Table I, sheet 12.
 - i. Clean all seating surfaces. Inspect metal surfaces and plastic parts for damage, which might impair sealing.
 - j. Replace defective parts. No adjustment or fitting is required to install RedQ replacement parts.
 - k. Lubricate threads with Alpha Molykote Type G for best performance. If hydrocarbons cannot be tolerated in the system, it is permissible to use M.W. Kellogg Co. Kel-F 90 or Fluorolube LF-160 grease, or FS-5 oil.
 - l. Replace valve guide in body, using special wrench and torque per Table I.
 - m. Reassemble soft seal valve seat unit. Place gasket on outside shoulder or seat.
 - n. Insert valve seat unit and gasket in regulator body.
 - o. Position valve seat bushing over valve seat and screw bushing into body, using wrench and torque per Table I.
 - p. If body plug gasket was removed, install a new one in groove on outside shoulder of body plug. If needed, use soft mallet to tap into groove with wood or plastic pin.
 - q. If valve is of standard construction, place valve spring and valve in body plug.
 - r. If valve is balanced type, reassemble body plug as follows:
 - i. Slide valve into seal retainer. (Check orientation of parts on assembly drawing.)
 - ii. Fit o-ring around seal and carefully slip together over lower end of valve. Use lubricant on o-ring, such as Marfak #3 or Kel-F-90 grease.
 - iii. Insert assembly (1) + (2) into body plug and seat the seal and o-ring securely.
 - iv. Using spanner wrench per Table I, screw seal retainer down into body plug recess.

- v. After seal and o-ring are seated, pull out valve.
- vi. Insert valve spring in valve and replace in seal retainer.
- s. If valve is balanced type, seat pushrod in recess on top of valve.
- t. Screw body plug and valve assembly up into body.

CAUTION:

Be sure that rod end of valve assembly fits up through valve guide, and valve parts seat evenly into valve seat unit. Hand tighten body plug until parts are seated properly.

- u. Tighten body plug with hex wrench, using size and torque given in Table I.
 - 5. Disassemble Powreactor diaphragm parts and/or convert to internal or external sensing as follows:
 - a. Be sure dome and line are vented as directed in Maintenance.-C.-3. Disconnect dome loading accessories, if any
 - b. Remove dome nuts, using wrench size given in Table I.
 - c. External loading plug & o-ring may be removed for cleaning and inspection.
 - d. If regulator has fixed dome plate:
 - i. Lift dome off of body, dowel pin will stay in body.
 - ii. Remove dome gasket.
 - e. If regulator has removable dome plate:
 - i. Lift dome off of dome plate
 - ii. Remove dome o-ring
 - iii. Lift dome plate off of body. Dowel pin remains in body.
 - iv. Remove seal from loading passage.
 - v. Orifice plug in dome plate may be removed for cleaning. Teflon seal plugs should be replaced if orifice plug is removed.
 - f. Loading needle valves may be removed for cleaning and inspection.
 - g. Remove diaphragm, diaphragm plate, and spring.
 - h. Sensing port in body is now exposed, for insertion or removal of internal sensing plug. See Installation-A, sheet 3.
 - i. Body plate should not normally be removed. If necessary to do so, it is possible to remove it using spanner wrench per Table I. Teflon seal plugs should be replaced if body plate is removed.
 - j. Clean non-metal parts and all metal clamping surfaces. Inspect metal surfaces and plastic parts for damage, which might impair sealing.
 - k. Replace defective part. No adjustment or fitting is required to install RedQ replacement parts.
 - l. Lubricate threads with Alpha Molykote Type G for best performance. If hydrocarbons cannot be tolerated in the system, use M.W. Kellogg Kel-F 90 or Fluorolube LG-160 grease, or FS-5 oil.
 - m. If body plate was removed, be sure valve guide is secure, using wrench and torque per Table I. Install new Teflon seal plugs and replace plate in body, using spanner wrench and torque per Table I.
 - n. If loading needle valves were removed, replace in body and dome plate.
 - o. If pushrod on balanced valve was removed, replace it through valve guide. Be sure it seats properly in head of valve.
 - p. Replace spring in diaphragm plate and seat over body plate.
 - q. Replace diaphragm over diaphragm plate
 - r. If regulator has fixed dome plate:
 - i. Replace dome gasket
 - ii. Replace dome over body
 - s. If regulator has removable dome plate:
 - i. If orifice plug was removed – install new Teflon seal plugs and replace orifice plug in dome plate
 - ii. Replace o-ring in loading duck in body
 - iii. Replace dome plate over body.
 - iv. Replace dome o-ring and dome over dome plate.
 - t. Tighten dome nuts evenly all around using wrench and torque per Table I.
- This completes replacement of parts in RedQ Powreactor Model 400, forged body design. Regulator is ready to put back into operation as directed in Adjustment.

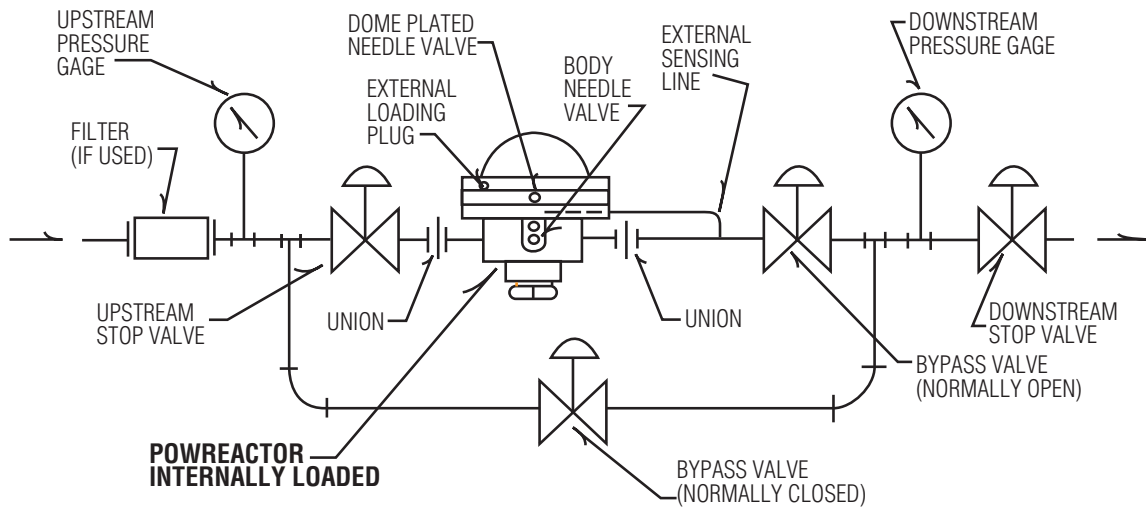

Figure 1 - Suggested Installation, Internally Loaded Models

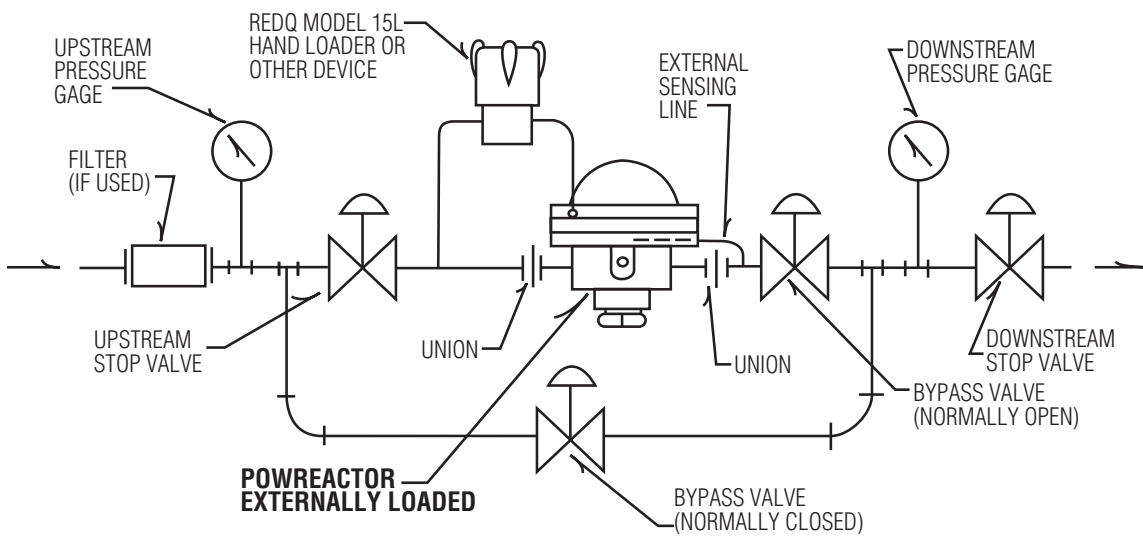

Figure 2 - Suggested Installation, Externally Loaded Models

Table 1 - Assembly Torques and Tools

*Item	Name	Used On	Part No.	Wrench	Torque
1	Needle valves, dome plate and body	All models with internal dome loading (402F, 412F)	20521-1 20522	5/32" hex key	30 inch-lb maximum
6	Valve guide	F models only	23158-1	5/8" across flats	15 ft-lb
15	Dome nut	All models: 3000 outlet 1000 outlet	12886 12859	15/16" hex	125 ft-lb
19	External dome loading plug	F model E model	035-08065-4 53914	11/16" hex 1/2" hex	To seal
20	Internal control plug	F models only	037-00104-1	3/16" hex key	To seal
22	Orifice plug	F models only	056-85601	5/16" hex key	30 ft-lb
24	Body plate	F models only	140-70023	Spanner wrench 21/64" holes on 4-7/8" ctrs	250 ft-lb
29	Body plug	All models w/3600 psi inlet w/6000 psi inlet	Various	3" hex 2-1/2" hex	180 ft-lb 180 ft-lb
32	Valve seat bushing Valve seat bushing	All models w/3600 psi inlet pressure rating All models w/6000 psi inlet pressure rating	Various Various	P/N 13003 Item 5 * P/N 13001 Item 5 *	100 ft-lb 100 ft-lb
34	Seal Retainer	All models with balanced valve	058-02004	Adjustable face spanner wrench, 1/8" holes on 1-47/64" ctrs	To shoulder
48	Loading passage plug	E models only	13906	9/32 sq.	
68	External control plug	F models only	035-16001-4	1" hex	To seal
119	Body plate capscrews	E models only	001-20504	Screw driver	Snug

* See Assembly Drawing or Parts List for Item Numbers

Appendix

Assembly Drawing	As Applicable
Parts List	As Applicable
Special tools:	As Applicable- See Table 1
Mounting Dimension Drawings	MODELS 401F, 411F W-401F-B01 CreS Assemblies W-401F-B02 Carbon Steel Assemblies W-401F-B03 CreS Assemblies w/ dissimilar port fittings MODELS 402F, 412F W-402F-B01 CreS Assemblies W-402F-B02 Carbon Steel Assemblies MODELS 402E, 412E see assembly drawing for overall dimensions

RedQ
Dresser, Inc.
2822 S. 1030 W.
Salt Lake City, Utah 84119
Phone: 801.487.2225 Fax: 801.487.2587
www.redqregulators.com

