

## G65 ROOTS® Meter

	<b>UNITS</b>	<b>Metric/DIN</b>	<b>UNITS</b>	<b>Metric/ANSI</b>
Temperature Range	deg. C	-40 to +70	deg. C	-40 to +70
Base Rating (Q Max.)	m <sup>3</sup> /h	100	m <sup>3</sup> /h	100
Max. Operating Pressure (MAOP)	bar	12	bar	12
Leak Test (125% MAOP)	bar	15	bar	15
Static Test (2 x MAOP)	bar	24	bar	24
Rangeability +/- 1%	ratio	89:1	ratio	89:1
Rangeability +/- 2%	ratio	163:1	ratio	163:1
Start Rate	m <sup>3</sup> /h	0,0595	m <sup>3</sup> /h	0,0595
Stop Rate	m <sup>3</sup> /h	0,0510	m <sup>3</sup> /h	0,0510
Flow Rate @ 1,25 mbar, Gas	m <sup>3</sup> /h	73,1	m <sup>3</sup> /h	73,1
Avg. Differential, 100% Flow	mbar	3,2	mbar	3,2
Max. Pressurization Rate	kPa/sec	35	kPa/sec	35
Max. Operating Speed	rpm	2350	rpm	2350
Gear Ratio	ratio	141,1764:1	ratio	141,1764:1
Displaced Volume/Revolution	m <sup>3</sup>	0,000708	m <sup>3</sup>	0,000708
Drive Rate	m <sup>3</sup> /rev	0,1	m <sup>3</sup> /rev	0,1
Min. Odometer Reading	m <sup>3</sup>	0,002	m <sup>3</sup>	0,002
Odometer Turnover	yrs.	1,14	yrs.	1,14
Nominal Pipe Size	mm	50	mm	50
Flange-to-Flange	mm	172	mm	172
Flange Connection	DIN	DN 50	ANSI	150#FF
Bolts per Flange	qty.	4	qty.	4
Bolt Size <sup>1</sup>	mm	M16	in.	5/8 - 11
Flange Bolt Hole Depth	mm	23,8	mm	23,8
Bolt Torque: Lubricated/Non-Lub.	N-m	74/81	N-m	74/81
Restricting Orifice (120%)	mm	9,525	mm	9,525
Oil Capacity – Side Inlet	ml	37	ml	37
Oil Capacity – Top Inlet	ml	226	ml	226
Net Weight	kg	13	kg	13
Shipping Weight	kg	14	kg	14
Carton Size	cm	69 x 28 x 23	cm	69 x 28 x 23

**NOTES:**

<sup>1</sup> Bolt Length varies by application.

---

Body Material	Aluminum
Impeller (Rotor) Material	Aluminum with stainless steel shaft
Application	Custody transfer approved by ANSI B109.3, MID & Others
Repeatability	0.1% (dependent on uncertainty of test equipment)
Security Seal	Option for seal wire or lead seal available
IP Rating for Euro-Counter Pulsar Only	IP65 (according to standard IEC 60529)

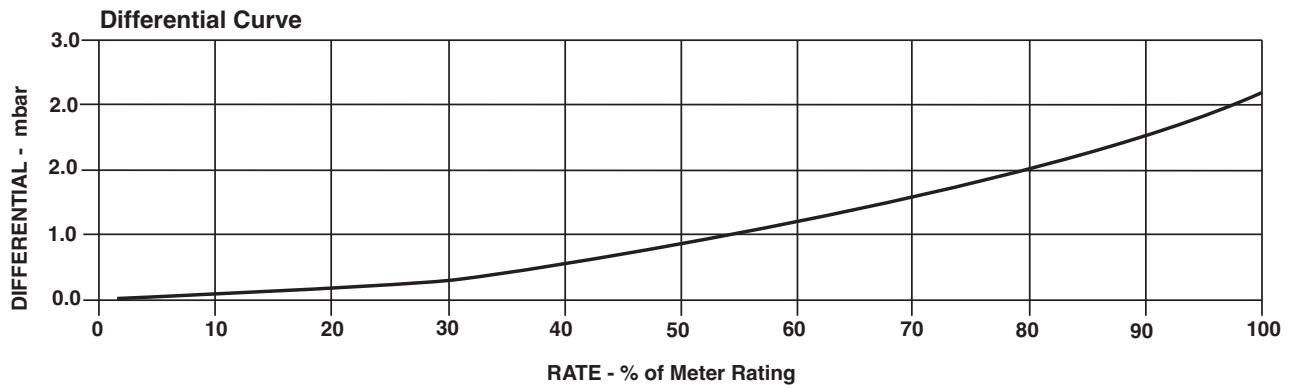
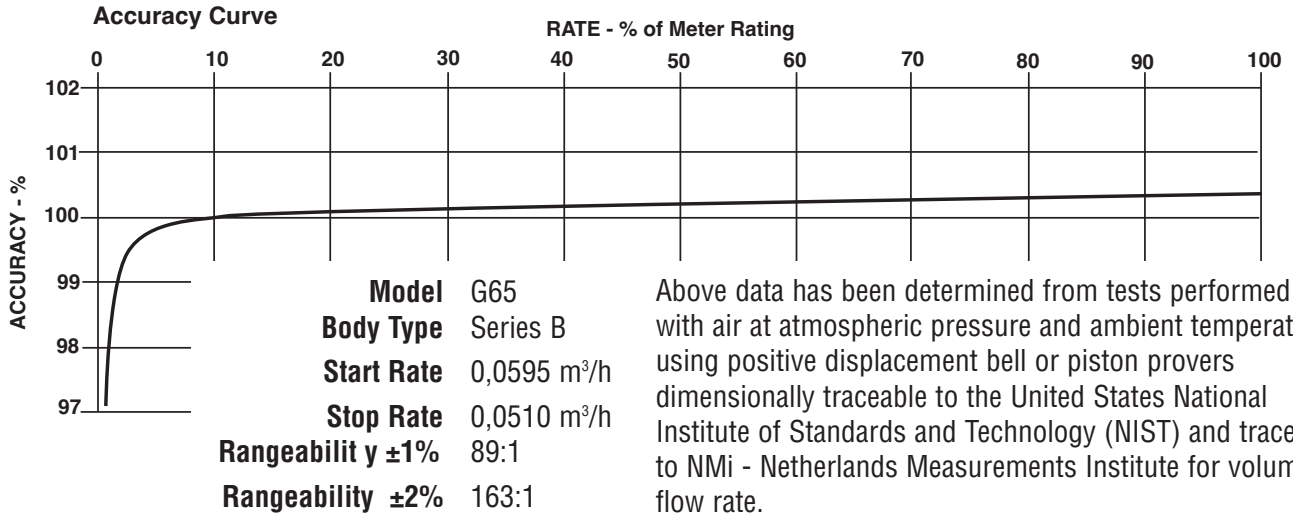

G65	Overall Length		Overall Height		Width (Flange/Flange)		Centerline to Accessory End (CL-AU)		Request Detailed Drawing Number
	inches	mm	inches	mm	inches	mm	inches	mm	
	15-13/64	386	6-31/32	177	6-3/4	172	8-15/16	227	D055451-000

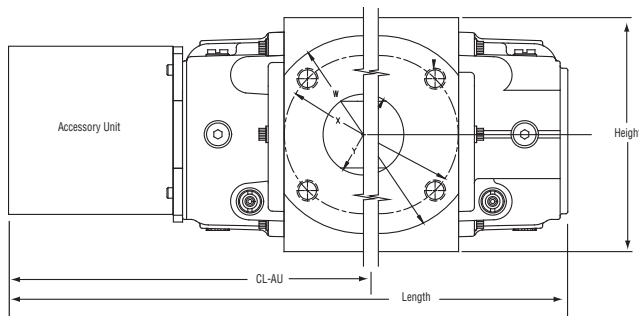

**Roots Meters & Instruments  
Dresser, Inc.**

16240 Port Northwest Drive  
Houston, Texas 77041-2645 USA  
Inside US Ph: 800.521.1114 Fax: 800.335.5224  
Outside US Ph: 832.590.2303 Fax: 832.590.2494



[www.dresser.com](http://www.dresser.com)