



G25 ROOTS® Meter

	UNITS	Metric/DIN	UNITS	Metric/ANSI
Temperature Range	Deg. C	-40 to +70	Deg. C	-40 to +70
Base Rating (Q Max.)	m ³ /h	40,0	m ³ /h	40,0
Max. Operating Pressure (MAOP)	bar	12	bar	12
Leak Test (125% MAOP)	bar	15	bar	15
Static Test (2 x MAOP)	bar	24	bar	24
Rangeability +/- 1%	ratio	37:1	ratio	37:1
Rangeability +/- 2%	ratio	73:1	ratio	73:1
Start Rate	m ³ /h	0,0549	m ³ /h	0,0549
Stop Rate	m ³ /h	0,0445	m ³ /h	0,0445
Flow Rate @ 1,25 mbar, Gas	m ³ /h	42,5	m ³ /h	42,5
Avg. Differential, 100% Flow	mbar	1,9	mbar	1,9
Max. Pressurization Rate	kPa/sec	35	kPa/sec	35
Max. Operating Speed	rpm	2350	rpm	2350
Gear Ratio	ratio	352,9411:1	ratio	352,9411:1
Displaced Volume/Revolution	m ³	0.000283	m ³	0.000283
Drive Rate	m ³ /rev	0,1	m ³ /rev	0,1
Min. Odometer Reading	m ³	0,002	m ³	0,002
Odometer Turnover	yrs.	2,85	yrs.	2,85
Nominal Pipe Size ²	mm	50	mm	50
Flange-to-Flange	mm	172	mm	172
Flange Connection ²	DIN	DN 50	ANSI	150#FF
Bolts per Flange	qty.	4	qty.	4
Bolt Size ¹	mm	M16	in.	5/8 - 11
Flange Bolt Hole Depth	mm	23,8	mm	23,8
Bolt Torque: Lubricated/Non-Lub.	N-m	74/81	N-m	74/81
Restricting Orifice (120%)	mm	9,5	mm	9,5
Oil Capacity – Side Inlet	ml	24	ml	24
Oil Capacity – Top Inlet	ml	89	ml	89
Net Weight	kg	11	kg	11
Shipping Weight	kg	12	kg	12
Carton Size	cm	56 x 26 x 20	cm	56 x 26 x 20

NOTES:

¹ Bolt Length varies by application.

² Available in 1-1/2" NPT nipped connections upon request.

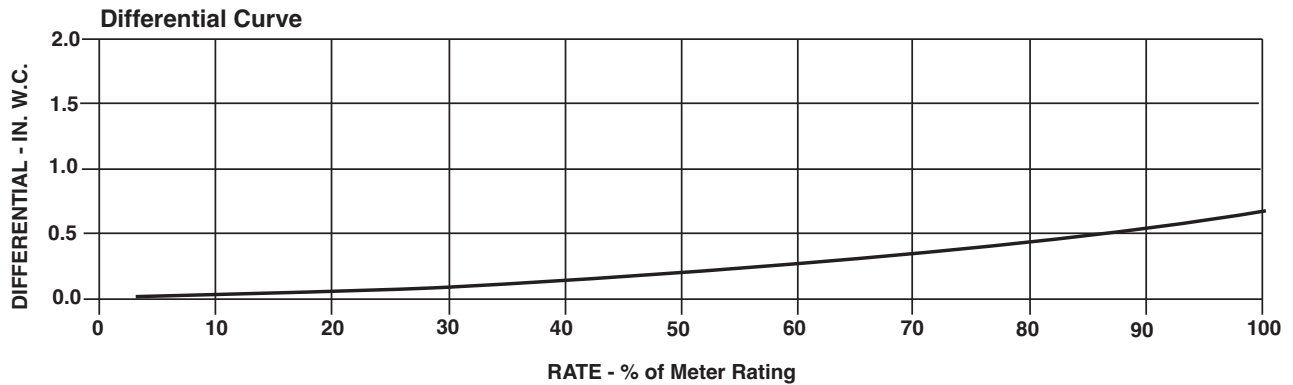
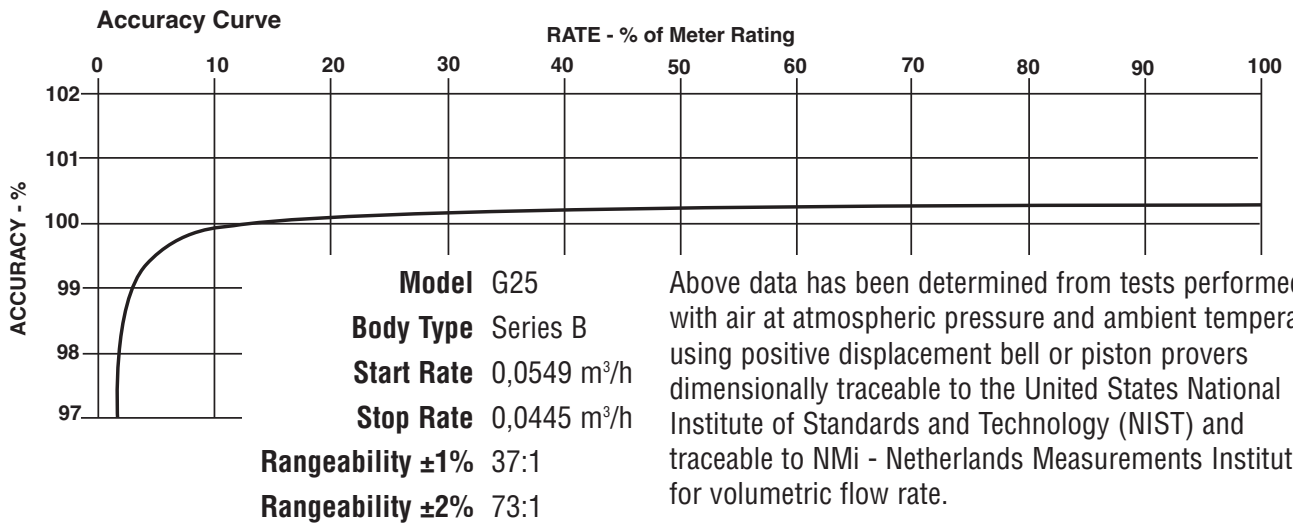

G25	Overall Length		Overall Height		Width (Flange/Flange)		Centerline to Accessory End (CL-AU)		Request Detailed Drawing Number
	inches	mm	inches	mm	inches	mm	inches	mm	
	13-55/64	352	6	153	6-3/4	172	8-15/32	215	D055450-000

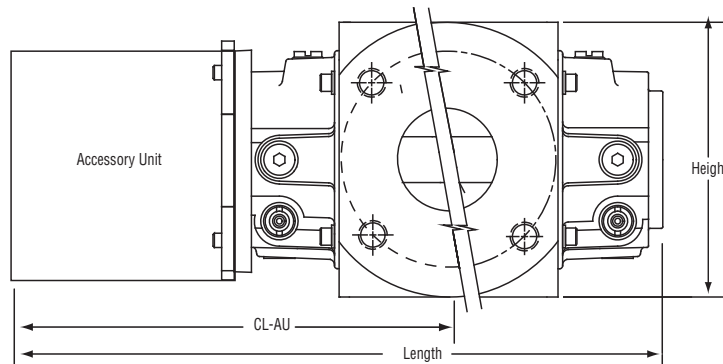

**Roots Meters & Instruments
Dresser, Inc.**

16240 Port Northwest Drive
Houston, Texas 77041-2645 USA
Inside US Ph: 800.521.1114 Fax: 800.335.5224
Outside US Ph: 832.590.2303 Fax: 832.590.2494



www.dresser.com