



G400 ROOTS® Meter

	UNITS	Metric/DIN	UNITS	Metric/ANSI
Temperature Range	deg. C	-40 to +70	deg. C	-40 to +70
Base Rating (Q Max.)	m ³ /h	650,0	m ³ /h	650,0
Max. Operating Pressure (MAOP)	bar	12	bar	12
Leak Test (125% MAOP)	bar	15	bar	15
Static Test (2 x MAOP)	bar	24	bar	24
Rangeability +/- 1%	ratio	40:1	ratio	40:1
Rangeability +/- 2%	ratio	60:1	ratio	60:1
Start Rate	m ³ /h	0,6513	m ³ /h	0,6513
Stop Rate	m ³ /h	0,5097	m ³ /h	0,5097
Flow Rate @ 1,25 mbar, Gas	m ³ /h	419,1	m ³ /h	419,1
Avg. Differential, 100% Flow	mbar	3,1	mbar	3,1
Max. Pressurization Rate	kPa/sec	35	kPa/sec	35
Max. Operating Speed	rpm	1,040	rpm	1,040
Gear Ratio	ratio	95,3323:1	ratio	95,3323:1
Displaced Volume/Revolution	m ³	0,010488	m ³	0,010488
Drive Rate	m ³	1,0	m ³	1,0
Min. Odometer Reading	m ³	0,020	m ³	0,020
Odometer Turnover	yrs.	1,76	yrs.	1,76
Nominal Pipe Size	mm	150	mm	150
Flange-to-Flange	mm	406,4	mm	406,4
Flange Connection	DIN	DN 150	ANSI	150#FF
Bolts per Flange	qty.	8	qty.	8
Bolt Size ¹	mm	M20	in.	3/4-10
Flange Bolt Hole Depth	mm	41,2	mm	41,2
Bolt Torque: Lubricate /Non-Lub.	N-m	108	N-m	108
Restricting Orifice (120%)	mm	37,306	mm	37,306
Oil Capacity – Side Inlet	ml	1,189	ml	1,189
Oil Capacity – Top Inlet	ml	4554	ml	4554
Net Weight	kg	92	kg	92
Shipping Weight	kg	105	kg	105
Carton Size	cm	112 x 61 x 56	cm	112 x 61 x 56

NOTES:

¹ Bolt Length varies by application.

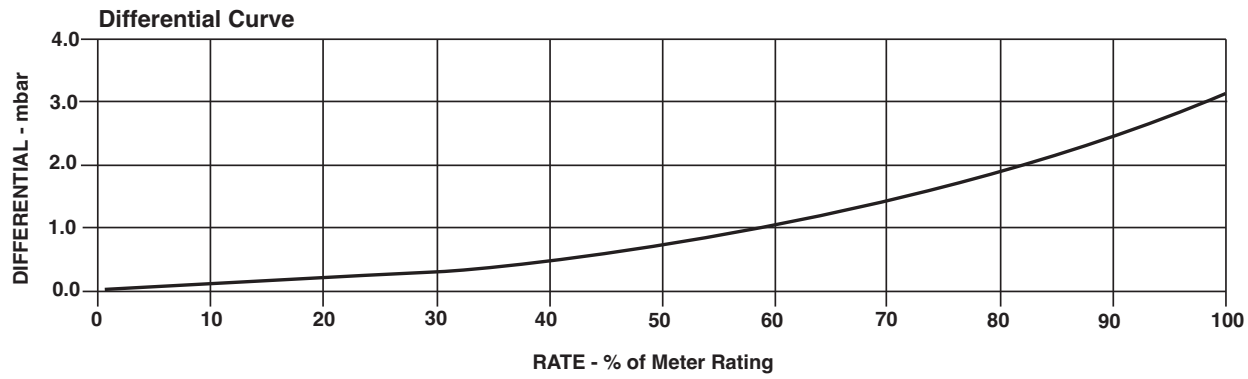
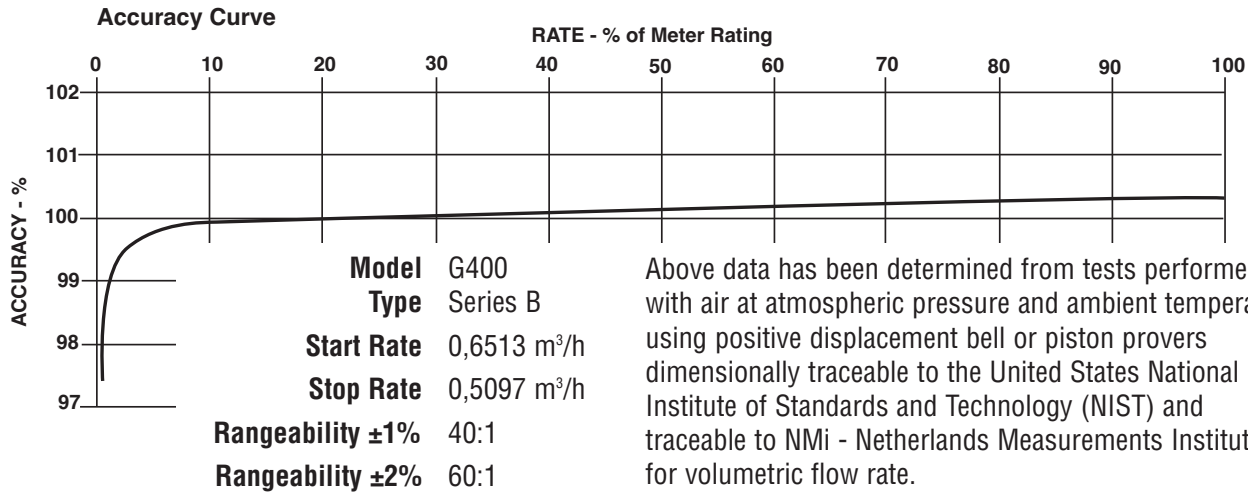

G400	Overall Length		Overall Height		Width (Flange/Flange)		Centerline to Accessory End (CL-AU)		Request Detailed Drawing Number
	inches	mm	inches	mm	inches	mm	inches	mm	
	26-15/16	684	18	458	16	406	14-49/64	375	D057674-000

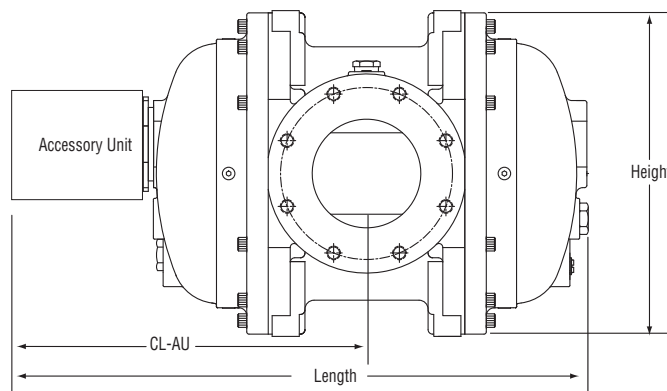

**Roots Meters & Instruments
Dresser, Inc.**

16240 Port Northwest Drive
Houston, Texas 77041-2645 USA
Inside US Ph: 800.521.1114 Fax: 800.335.5224
Outside US Ph: 832.590.2303 Fax: 832.590.2494



www.dresser.com