



SERIES B3: G40 ROOTS® Meter

	UNITS	Metric/DIN	UNITS	Metric/ANSI
Temperature Range	deg. C	-40 to +60	deg. C	-40 to +60
Base Rating (Q Max.)	m ³ /h	65,0	m ³ /h	65,0
Max. Operating Pressure (MAOP)	bar	12	bar	12
Leak Test (125% MAOP)	bar	15	bar	15
Static Test (2 x MAOP)	bar	24	bar	24
Rangeability +/- 1%	ratio	78:1	ratio	78:1
Rangeability +/- 2%	ratio	144:1	ratio	144:1
Start Rate	m ³ /h	0,0538	m ³ /h	0,0538
Stop Rate	m ³ /h	0,0311	m ³ /h	0,0311
Flow Rate @1,25 mbar, Gas	m ³ /h	56,6	m ³ /h	56,6
Avg. Differential, 100% Flow	mbar	2,2	mbar	2,2
Max. Pressurization Rate	kPa/sec	35	kPa/sec	35
Max. Operating Speed	rpm	1920	rpm	1920
Gear Ratio	ratio	176,4705:1	ratio	176,4705:1
Displaced Volume/Revolution	m ³	0,000566	m ³	0,000566
Drive Rate, CTR, CD	m ³ /rev	0,1	m ³ /rev	0,1
Min. Odometer Reading	m ³	0,002	m ³	0,002
Odometer Turnover	yrs.	1,75	yrs.	1,75
Nominal Pipe Size	mm	50	mm	50
Flange-to-Flange	mm	172	mm	172
Flange Connection	DIN	DN 50	ANSI	150#FF
Bolts per Flange	qty.	4	qty.	4
Bolt Size ¹	mm	M16	in.	5/8 - 11
Flange Bolt Hole Depth	mm	23,8	mm	23,8
Bolt Torque: Lubricated/Non-Lub.	N-m	74/81	N-m	74/81
Restricting Orifice (120%)	mm	11,113	mm	11,113
Oil Capacity – Side Inlet	ml	37	ml	37
Oil Capacity – Top Inlet	ml	226	ml	226
<i>Counter Version (CTR)²</i>				
Net Weight	kg	12	kg	12
Shipping Weight	kg	13	kg	13
Carton Size	cm	69 x 28 x 23	cm	69 x 28 x 23
<i>Counter with Instrument Drive (CD)²</i>				
Net Weight	kg	14	kg	14
Shipping Weight	kg	15	kg	15
Carton Size	cm	79 x 38 x 33	cm	79 x 38 x 33

NOTES:

¹ Bolt Length varies by application.

² Weights and dimensions available for CPS upon request.

Accuracy Curve

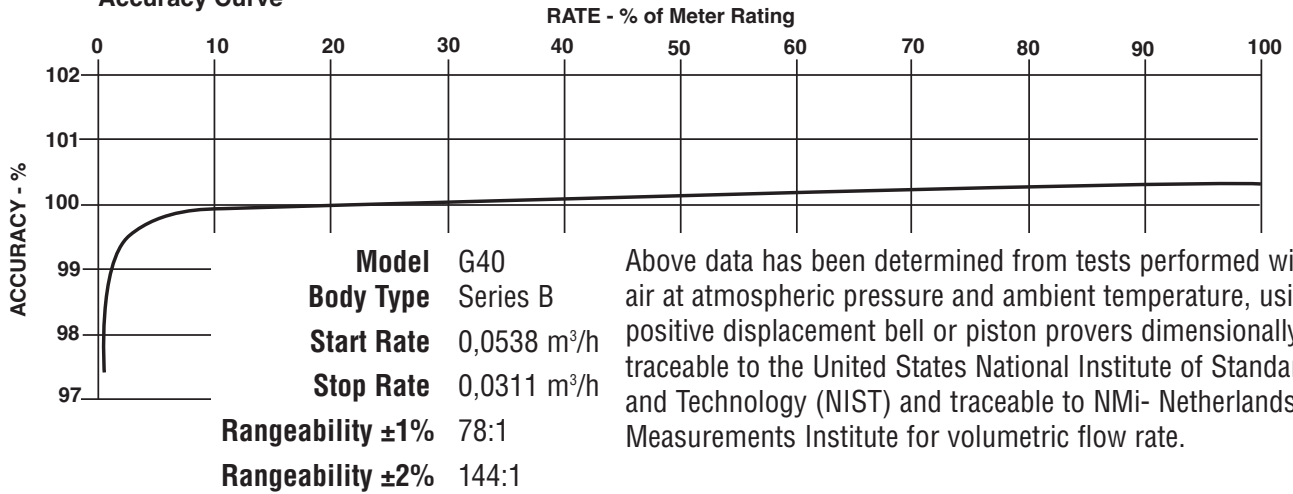

Differential Curve

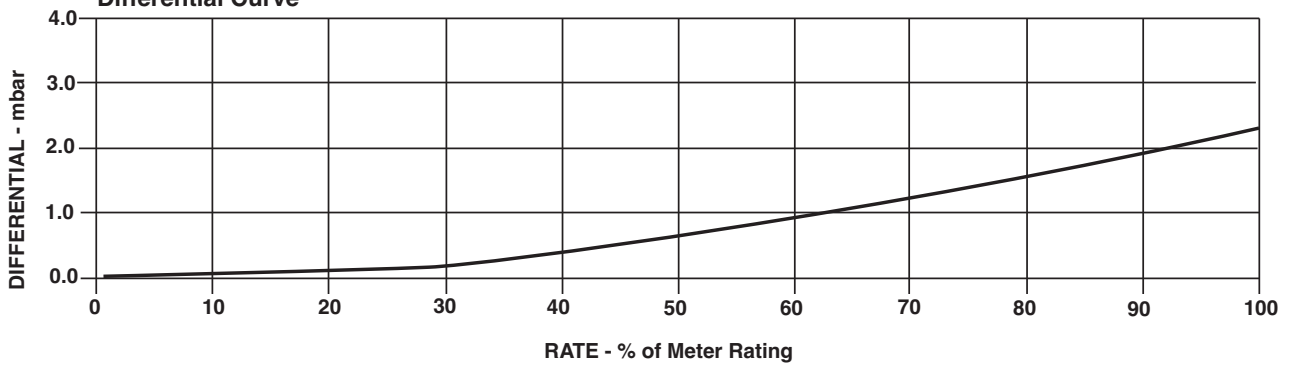

G40 Series B3	Overall Length		Overall Height		Width (Flange/Flange)		Centerline to Accessory End (CL-AU)		Request Detailed Drawing Number
	inches	mm	inches	mm	inches	mm	inches	mm	
CTR	15-7/8	403	6-31/32	177	6-3/4	172	10-3/16	259	D054517-000
CD	19-25/32	503	6-31/32	177	6-3/4	172	14-1/8	359	D054431-000
ICPS	17-3/8	441	6-31/32	177	6-3/4	172	11-3/4	298	D056900-000
IMC/C2	19-13/32	493	6-31/32	177	6-3/4	172	13-3/4	349	D056486-000
IMC/W2	20-13/32	518	6-31/32	177	6-3/4	172	14-3/4	375	D056702-000

To order

Specify: Meter Series, Size and Type (i.e., ROOTS Meter Series B3 G40 CD).

For CD, specify Inlet (Top or Side) and ID Rotation (CW-B or CCW-A).

For Pulsar, specify Single or Dual Connectors and Connector Type (MS Circular, Conduit or Cable Gland).

For more specific ordering information on the electronic products, request: TS:SSP, TS:IMC/C2, or TS:IMC/W2.

Contact the factory for other available information, options, or special requests.

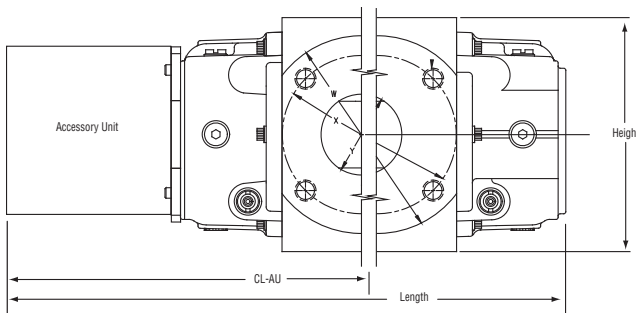

Roots Meters & Instruments Dresser, Inc.

16240 Port Northwest Drive
 Houston, Texas 77041-2645 USA
 Inside US Ph: 800.521.1114
 Outside US Ph: 832.590.2303

Fax: 800.335.5224
 Fax: 832.590.2494



www.dresser.com