

Dresser Roots®
Micro Series Volume Corrector
Handbook

4-2820 Revision 1

PH030

Contents

1.	Information	3
2.	General Overview	4
2.1	Models Available	5
2.1.1	Hardware Link Protected	5
2.1.2	Password Protected	5
2.1.3	Accessories	5
3	Specification and Details	6
3.1	Pressure Measurement	6
	Table 1 – Pressure Transducer Accuracy Reference Table	6
3.2	Temperature Measurement	7
3.3	Volume Input	7
3.4	Telemetry Output	7
3.5	Units of Measurement	8
3.6	Size	8
	Figure 1 - (MC Dimension Considerations)	8
3.7	Serial Port	9
3.8	Display	9
	Table 2 – LCD and Alarm Conditions	9
3.9	Memory	10
3.10	Internal Supply	10
3.11	Environment	10
4	Safety	11
	Table 3 – Capacitance and Inductance or Inductance to Resistance Table	11
	Figure 2 – Intrinsic Safety System Diagram for EECs Compliance	12
5	Installation	13
5.1	Unpacking	13
5.2	Safety Requirements	13
5.3	EMC Compatibility	14
5.4	Mechanical Installation	14
	Figure 3 – MC Mounting Hole Pattern	14
5.4.1	Setting the <i>Weights and Measures</i> Link	15
	Figure 4 – Setting the <i>Weights and Measure</i> Link (Hardware Link)	16
5.5	Electrical Installation	16
5.5.1	Location of the Connection Terminals	17
	Figure 5 – Location of the Connection Terminals	17
5.5.1.1	Volume Input (TB1)	18
	Figure 6 – Volume Input TB1 Connections	18
5.5.1.2	Temperature Measurement (TB2)	19
	Figure 7 – Temperature Transducer Connections (TB2)	19
5.5.1.3	Telemetry Output (TB3)	19
	Figure 8 – Telemetry Output Connections (TB3)	20
6.	Maintenance	21
6.1	Replacing the Battery Pack	22
6.2	Pressure Transducer Recalibration	22
6.3	Temperature Transducer Recalibration	23
6.4	Restoring Factory Defaults	23
6.5	Service	23
7.	Appendix A – Ordering Information	24
7.1	Model Part Number Formulation	24
	Figure 9 – Model Part Number Formulation Guide	24
7.2	Worked Examples	24
7.2.1	Example 1	24
7.2.2	Example 2	25
	Table 4 – Model Part Number Formulation Reference Table	25

1. Information

This handbook details the installation and operation of all varieties of the Dresser Roots ® Micro Series Volume Corrector (MC). The MC is manufactured by:

D I UK Limited (Dresser)
Unit 1, Yeoman Industrial Park
Test Lane
Nursling
Southampton
Hampshire
SO16 9JX
United Kingdom

Tel: +44 (0)23 8087 5600

Fax: +44 (0)23 8087 5601

Your local agent / distributor is:

All printed material contained within this handbook is for information only and is subject to change without notice.

This manual uses the words corrector, corrected and uncorrected throughout. The words corrector, corrected and uncorrected should be read in Europe as meaning convertor, converted and unconverted as defined by the most recent standards on volume conversion. The term *drive rate* should be read in Europe as meaning *meter pulse significance*.

In addition, the term *telemetry output pulse* should be read in the USA as meaning *pulse output*.

In the case of the MC T-Only and when a fixed line pressure is applied, the corrected and uncorrected volumes should be read as meaning compensated and uncompensated.

2. General Overview

The Dresser Roots ® Micro Series Volume Corrector (MC) combines 2 devices; an electronic counter and a volume corrector. The MC is compatible with all Roots ® meters and others (contact your distributor for further details). Volume is sensed from low frequency pulses provided by positive volume displacement meters such as the Dresser Roots® rotary meter or a reed switch.

The MC is designed to measure live pressure and temperature to calculate corrected volume. In addition optional features are available and include:

- Data and Audit Logging.
- Trim Table options.

Note: a temperature only version of the MC, the MC T-Only is also available. The MC T-Only measures live temperature and hence the operator has to configure a fixed line pressure value. All functionality, with exception of the live pressure measurement is identical to that of the MC, and the details contained within this handbook should be read as being applicable to both.

The MC utilises E²PROM memory which eliminates the need for back up batteries and hence all set up data, and data and audit log entries (where applicable) will be stored during periods of no power. The data logging facility, when selected provides the operator with 3 independent operator configurable logging periods. The audit logging facility provides a means of tracking up to the latest 32 changes to the configuration parameters. Both the data and audit logs are saved as CSV (comma-delimited) files to allow easy import into spreadsheets such as Microsoft Excel or Lotus 123. For further details regarding the data and audit logging facility consult the MC User Terminal Handbook.

The MC unit is designed (and approved intrinsically safe (I.S.)) for use in hazardous areas. A serial port allows communication with the unit; configuration and interrogation is therefore possible, either directly via a laptop or remotely, via the Micro Modem. The unit can be used with this modem to initiate dial-out calls under alarm conditions as required by the operator.

The MC is set up and calibrated from a laptop computer via the serial port using Dresser's "Micro Corrector User Terminal" software. This will allow:

- Set up
- Calibration
- Data extraction
- Alarm monitoring

2.1 Models Available

The MC is factory built to suit customer order requirements. Options selectable include:

- Pressure measurement (without the pressure option the unit is a MC T-Only).
- External (with respect to the meter) absolute or gauge pressure measurement in the following ranges: 2, 12, and 24. In addition a 30 and a 70 bar absolute pressure transducers are also available.
- Platinum resistance thermometer (PT100) (temperature probe).
- Hardware link protected (read / write link) or password protected - see sections 2.1.1 (*Hardware Link Protected*) and 2.1.2 (*Password Protected*) for more details.

For ordering information refer to Appendix A (*Ordering Information*); see sections [7.1 \(Model Part Number Formulation\)](#) and [7.2 \(Worked Examples\)](#).

2.1.1 Hardware Link Protected

To comply (where applicable) with the *Weights and Measures* legislation (e.g. Canada, Europe) the MC is designed with a hardware protection link which allows a *Read Only* style of communication between the operator's computer and the MC. The protection link is shipped in the *Read / Write* position but can be switched to the *Read Only* position. When in the *Read Only* position it is not possible to make changes to the measurement parameters without physically breaking a seal. Initial set up and configuration of the MC will require the protection link to be placed in the *Read / Write* position, refer to section [5.4.1 \(Setting the Weights and Measures Link\)](#).

2.1.2 Password Protected

If the password protected method is required the physical position of the *Weights and Measures* protection link is ignored allowing all measurement parameters to be written over the serial link. Password protection is applied to these parameters.

2.1.3 Accessories

The MC Communication Pack consists of a 2m serial link cable terminated in a 7 pin screw locking DIN plug and 9 way "D" connector and application software CD (3.5 ins diskette available on request). The pack is required for commissioning and configuring the MC as well as retrieving logged data.

Other additional accessories available include:

- Replacement temperature probe.
- Replacement alkaline battery pack.
- Additional handbook – English.
- Intrinsically safe Micro Series Modem.
- 5m modem cable.
- Spare hexagon wrenches (Allen keys).
- Quick fix mounting brackets.
- Various MC installation kits consisting of isolation valve, pressure piping and pressure test point.

Please contact your distributor for further details.

3 Specification and Details

3.1 Pressure Measurement

The MC is fitted with 1 pressure transducer (where required). The pressure port is a 1/8" NPT male fitting. The various pressure transducers and associated percentage of accuracy are listed in table 1 (*Pressure Transducer Accuracy Reference Table*).

Table 1 – Pressure Transducer Accuracy Reference Table

Pressure Transducer Range	Details
2 Bar A / 30 PSI A	MC accuracy < 0.5% reading between 0.8 Bar A and 2 Bar A over temperature range -40°C to 60°C. / MC accuracy < 0.5% reading between 12 PSI A and 30 PSI A over temperature range -40°F to 140°F.
12 Bar A / 175 PSI A	MC accuracy < 0.5% reading between 2 Bar A and 12 Bar A and <0.5% of 2 Bar A below 2 Bar A over temperature range -40°C to 60°C. / MC accuracy < 0.5% reading between 15 PSI A and 175 PSI A and <0.5% of 15 PSI A below 15 PSI A over temperature range -40°F to 140°F.
24 Bar A / 350 PSI A	MC accuracy < 0.5% reading between 4 Bar A and 24 Bar A and <0.5% of 4 Bar A below 4 Bar A over temperature range -40°C to 60°C. / MC accuracy < 0.5% reading between 58 PSI A and 350 PSI A and <0.5% of 58 PSI A below 58 PSI A over temperature range -40°F to 140°F.
30 Bar A / 430 PSI A	MC accuracy < 0.5% reading between 5 Bar A and 30 Bar A and <0.5% of 5 Bar A below 5 Bar A over temperature range -40°C to 60°C. / MC accuracy < 0.5% reading between 70 PSI A and 430 PSI A and <0.5% of 70 PSI A below 70 PSI A over temperature range -40°F to 140°F.
70 Bar A / 1015 PSI A	MC accuracy < 0.5% reading between 13 Bar A and 70 Bar A and <0.5% of 13 Bar A below 13 Bar A over temperature range -40°C to 60°C. / MC accuracy < 0.5% reading between 188 PSI A and 1000 PSI A and <0.5% of 188 PSI A below 188 PSI A over temperature range -40°F to 140°F.
2 Bar G / 30 PSI G	MC accuracy < 0.5% reading (P + Pa) between 0.35 Bar G and 2 Bar G and <0.5% of 0.35 Bar G (P + Pa) below 0.35 Bar G over temperature range -40°C to 60°C. / MC accuracy < 0.5% reading (P + Pa) between 5 PSI G and 30 PSI G and <0.5% of 5 PSI G (P + Pa) below 5 PSI G over temperature range -40°F to 140°F.
12 Bar G / 175 PSI G	MC accuracy < 0.5% reading (P + Pa) between 1 Bar G and 12 Bar G and <0.5% of 1 Bar G (P + Pa) below 2 Bar G over temperature range -40°C to 60°C. / MC accuracy < 0.5% reading (P + Pa) between 15 PSI G and 175 PSI G and <0.5% of 15 PSI G (P + Pa) below 15 PSI G over temperature range -40°F to 140°F.
24 Bar G / 350 PSI G	MC accuracy < 0.5% reading (P + Pa) between 4 Bar G and 24 Bar G and <0.5% of 4 Bar G (P + Pa) below 4 Bar G over temperature range -40°C to 60°C. / MC accuracy < 0.5% reading (P + Pa) between 58 PSI G and 350 PSI G and <0.5% of 58 PSI G (P + Pa) below 58 PSI G over temperature range -40°F to 140°F.

The transducer burst pressure will exceed transducer range +20% for all the transducers provided.

3.2 Temperature Measurement

Temperature measurement is performed by a 4-wire Class A 100 ohm platinum resistance thermometer (temperature probe) supplied as an option with the MC. It is housed in a stainless steel probe body 50mm x 6.0mm dia. (2 ins x 1/4 ins dia) and the probe head is 25mm x 4mm dia. (1 ins x 1/6 ins dia). An armoured cable option is also available; this is housed in a stainless steel probe body 82mm x 6.0mm dia. (3 1/5 ins x 1/4 ins dia.) and the probe head is 56mm x 4mm dia. (2 1/5 ins x 1/6 ins dia). The wiring connections are made to a terminal block inside the MC.

MC accuracy for temperature is better than 0.5°C (0.9°F) over the temperature range -40°C to 60°C (-40°F to 140°F).

For connection details refer to section [5.5.1.2 \(Temperature Measurement \(TB2\)\)](#).

3.3 Volume Input

The MC accepts low frequency pulses from positive displacement meters such as the Dresser Roots® rotary meters. The meter must be fitted with a LF pulser such as the Roots® Solid State pulser or a dry LF Reed Switch. If the meter is fitted with a mechanical drive a Dresser Mechanical Pickup Adapter will convert the mechanical drive to a suitable pulse from the MC.

The value of the input pulses depends on the drive rate (pulse significance) and its associated *revolutions / units* (rev/m³ or rev/ft³) value. For further details consult the MC User Terminal Handbook.

For connection details refer to section [5.5.1.1 \(Volume Input \(TB1\)\)](#).

3.4 Telemetry Output

There are 3 isolated outputs (uncorrected, corrected and fault), and 2 ground terminals. These ground terminals are isolated from the other ground terminals of the MC. Each output is an open drain connection capable of sinking 10mA and withstanding up to 15 Volts (5 Volts max. above +40°C or +104°F). An external “pull up” resistor or current source is normally required to ensure that the circuit will function correctly. The significance of the pulse outputs are operator configurable from within the User Terminal, and may be set independently for uncorrected and corrected volume to 0.1 / 1 / 10 / 100 / 1000 as required by the operator and as defined by meter type.

The outputs are connected to a terminal block (TB3) mounted internally and provide:

- Uncorrected volume pulses.
- Corrected volume pulses.
- Fault / Alarm indication.

The uncorrected and corrected outputs are isolated from each other (via *TGND2* (uncorrected) and *TGND1* (corrected)). The fault output shares the *TGND1* ground terminal with the corrected output.

The “ON” duration of the pulses at outputs 1 and 2 may be configured to 125mS, 187mS or 315mS to suit the driven equipment. The Fault / Alarm indication (when configured) will pulse at approximately 1Hz when a fault condition is present.

The connection details for the telemetry output are shown in section [5.5.1.3 \(Telemetry Output \(TB3\)\)](#).

3.5 Units of Measurement

The MC units are selectable during operator set up and can be set to imperial, metric or a combination of both in the same configuration, for example °C and cu ft. Refer to the MC User Terminal Handbook for further details.

3.6 Size

Consideration should be taken to leave sufficient space below the corrector for running the cabling and pressure piping and to allow access to the serial communication port. A drawing showing the overall dimensions of the MC and location of the connections is shown in Figure 1 (*MC Dimension Considerations*).

For protection against static damage, it is essential that anti-static precautions are taken when the corrector is opened for installation or maintenance.

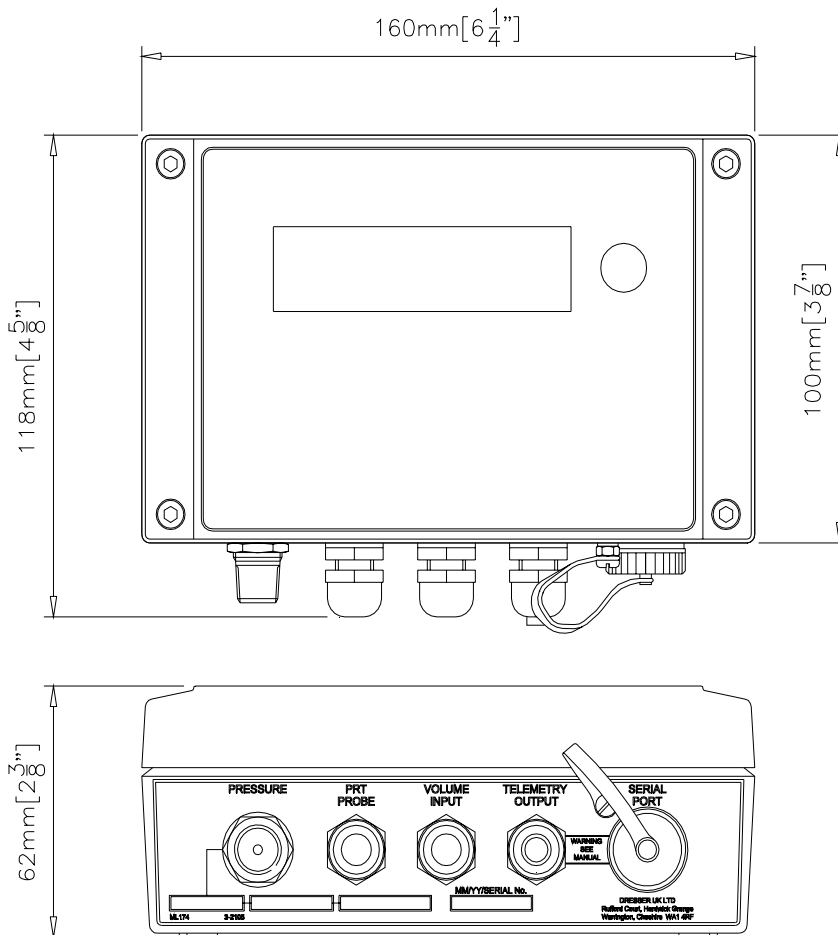

Figure 1 - (MC Dimension Considerations)

3.7 Serial Port

The MC is fitted with an external 7 pin screw locking DIN connector for the serial port connections. Logic levels are 5 – 12V into the MC with a 5V nominal output from the MC (RS232 / RS232C levels).

3.8 Display

The LCD display is permanently active and operational over the temperature range -40°C to 60°C (-40°F to 140°F).

Depending on the particular model option chosen and the operator’s configuration of the unit, the front panel selector button enables the MC to display the following parameters:

- Corrected Volume.
- Uncorrected Volume.
- Flow Rate.
- Correction Factor.
- Drive Rate.
- Line Pressure.
- Temperature.
- Uncorrected Volume Under Fault.
- Corrected Residual.
- Uncorrected Residual.
- Firmware Version.
- Atmospheric Pressure.*
- Base Pressure.
- Pressure Factor.
- Supercompressibility.
- Battery Voltage.
- Current Date.
- Current Time.
- Test Screen.

*Only where applicable, i.e. if transducer is gauge.

It is possible to specify which parameters are displayed on the LCD and which parameter is displayed by default. When shipped, the MC will display all parameters with the Corrected Volume being default.

In alarm and / or fault conditions a message may be displayed on the LCD indicating the nature of the alarm and / or fault, see Table 2 (*LCD and Alarm Conditions*). For further information regarding the LCD consult the MC User Terminal Handbook.

Table 2 – LCD and Alarm Conditions

LCD Alarm Code	Alarm Condition	Additional Symbols Displayed
HP AL	High Pressure alarm	N/A
LP AL	Low Pressure alarm	N/A
Ht AL	High Temperature alarm	N/A
Lt AL	Low Temperature alarm	N/A
HF AL	High Flow alarm	N/A
LF AL	Low Flow alarm	N/A
LCD Fault Code	Fault Condition	Additional Symbols Displayed
Lo bAtt	Low Battery	Battery icon
P FLt	Pressure Fault	Alarm bell icon
T FLt	Temperature Fault	Alarm bell icon
Int FLt	Internal Operations Fault	Alarm bell icon

3.9 Memory

The MC has a non-volatile memory and on battery failure will retain all of the totals obtained within the last hour of operation and all set up data. These will be available and ready for use as soon as power is restored.

Data logs (order dependant) are continually stored in the memory; the total number of logs depends on the configuration of both the log parameters and logging periods, a data log may contain any of the following information:

- Corrected Volume.
- Uncorrected Volume.
- Correction Factor.
- Uncorrected Volume under Fault.
- Line Pressure.
- Temperature.
- Average Corrected Flow Rate.
- Peak Corrected Flow Rate.

For further information regarding the data logs consult the MC User Terminal Handbook.

3.10 Internal Supply

The MC is powered by an internal battery pack giving a normal life of 5 years. The actual length of the battery life will depend on the conditions of use. The state of the battery is monitored and a low battery alarm is given at least 2 months before the batteries are exhausted. It is recommended that the front panel selector button is pressed before changing the battery (see section [6.1 \(Replacing the Battery Pack\)](#)).

Short term power is supplied via a super capacitor to allow the unit to continue to function during battery replacement.

For safety reasons, only the whole battery pack must be replaced.

3.11 Environment

The MC may be operated over the following ranges:

Temperature:	-40°C to 60°C (-40°F to 140°F).
Humidity:	0 – 95% (condensing).
EMC:	EN50081-1 and EN50082-2 Meets FCC class B requirements.
Ingress:	IP66 and NEMA 4X for dust and water penetration, i.e. fully weatherproof.

4 Safety

The MC is intrinsically safe.

EEx ia IIC T4 (-40°C < T amb < 60°C).

BAS No's. Ex98E2081, Ex98E2082, ATEX BAS98ATEX1083X

The connection of the MC to other instruments must be carried out in accordance with the Intrinsic Safety System Diagram shown in Figure 2 (*Intrinsic Safety System Diagram for EECS Compliance*). Use Figure 2 (*Intrinsic Safety System Diagram for EECS Compliance*) to achieve compliance with EECS requirements, with consideration to the following notes:

1. The installation must comply with the appropriate national installation conditions, e.g. in the UK BS 5345: Part 4:1977 or BS EN 60079-14.
2. The external circuits must be capable of withstanding an A.C. test voltage of 500V to earth or frame of the equipment, for a period of 1 minute, without breakdown.
3. Wiring for each external circuit may be achieved by separate cables or by separate circuits within a Type A or Type B multicore cable (as defined in clause 5.3 of EN50039).
4. The cables from the temperature probe and volume reed connections must not exceed 6m in length.
5. The capacitance and inductance or inductance to resistance (L / R) ratio of the cable connected to the telemetry output must not exceed the values shown in Table 3 (*Capacitance and Inductance or Inductance to Resistance Table*).
6. The serial port may only be connected to a computer when both the computer and MC can be regarded as being located in a non-hazardous area. The computer must be powered from a self contained battery and must not contain voltages in excess of 25V. The interconnecting cable must contain only 3 cores, connected to pins 1, 2 and 7 of the serial port connector. Pins 4 and 6 may be joined within the connector. Each conductor must have a minimum 0.25mm radial insulation.
7. The serial port may be connected to the I.S. modem (Cert No. BAS99ATEX7049) at any time in accordance with Figure 2 (*Intrinsic Safety System Diagram for EECS Compliance*), and then the cable must comply with note 5.

Table 3 – Capacitance and Inductance or Inductance to Resistance Table

Group	Capacitance C _o in μF	Inductance L _o in mH	OR	L/R ratio L _o /R in μH/ohm
IIC	0.102	0.4		78
IIB	0.84	2.7		363
IIA	2.97	5.3		775

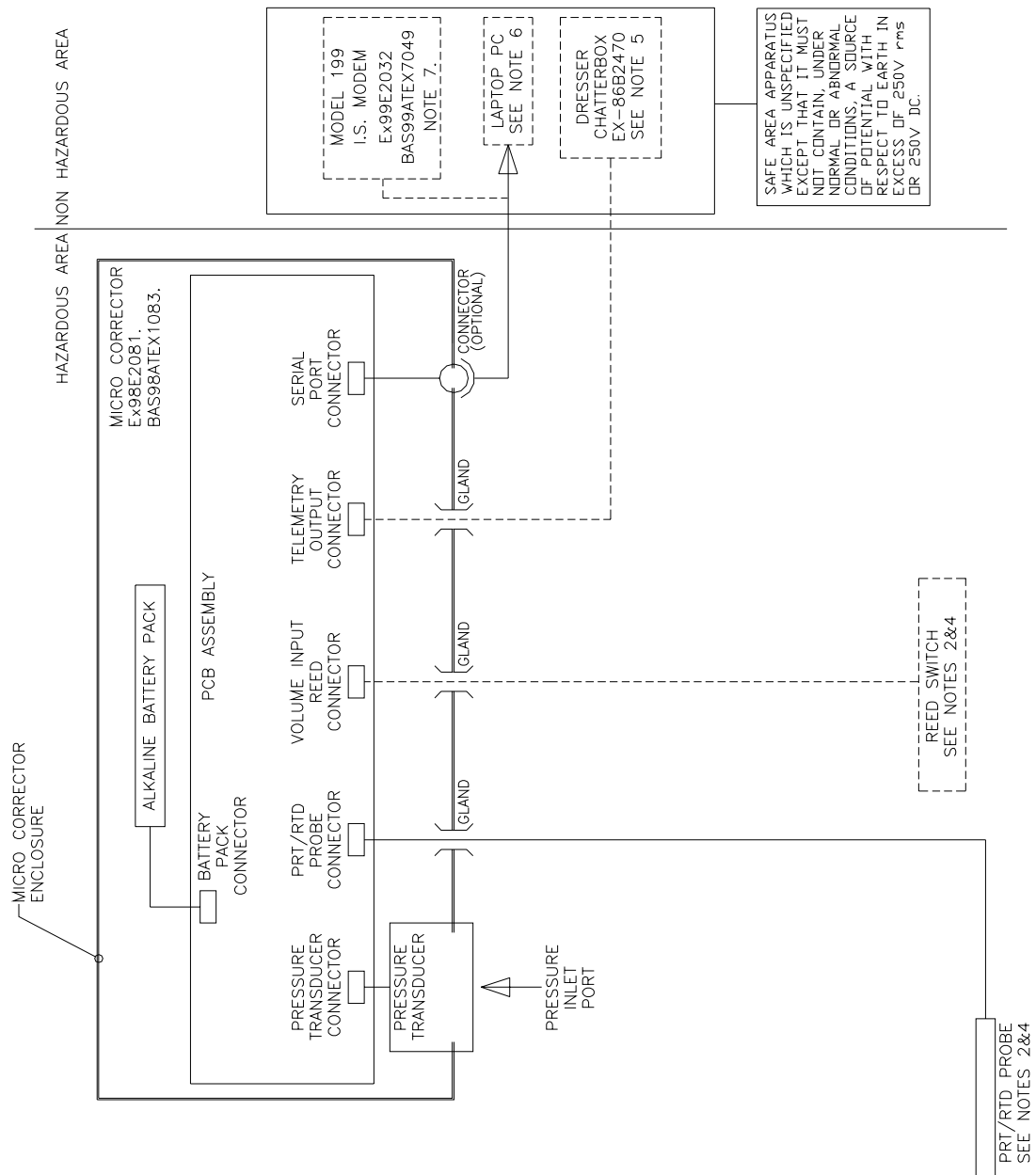

Figure 2 – Intrinsic Safety System Diagram for EECS Compliance

5 Installation

5.1 Unpacking

The following items are supplied with the MC:

	Quantity
• MC Handbook	1
• 3mm hexagon wrench (Allen key)	1
• Spacer	4
• M6 x 20 panel mounting screw	4
• Calibration certificate	1
• Temperature probe (subject to order)	1

The User Terminal is supplied with an additional handbook for guidance of use of the software. This is included in the User Terminal CD.

5.2 Safety Requirements

Where an MC installation must meet Intrinsic Safety requirements, refer to the Intrinsic Safety System Diagram (*Figure 2*) and section 4 *Safety* before commencing installation. It is essential to follow any National Codes of Practice dealing with Intrinsically Safe installations. All Intrinsically Safe circuits must be segregated from non-I.S. circuits. The transducers used in and with the MC are intrinsically safe.

In line with the system drawings the MC must only be powered by the approved Dresser battery pack.

Connection to intrinsically safe equipment not detailed in the system drawing must be properly assessed by the user and the manufacturer (Dresser) will not take responsibility for the overall safety of the system.

The serial port may only be connected to an intrinsically safe modem as shown by the system approval drawing. For commissioning and reading data the serial port may also be connected to a lap top computer under the following conditions:

- Lap top computers, generally, are not intrinsically safe. Therefore, before using an uncertified lap top in the hazardous area, a gas test should be performed to prove that no potentially hazardous gas mixture exists in the area. If this is not possible the lap top must not be used in the hazardous area.
- The lap top computer must be powered by batteries alone and these must be incapable of supplying more than 25 Volts. No connection is to be made to an external supply (e.g. charger) even if non-operational. (The presence of the connection can itself create a hazardous condition).

An intrinsically safe barrier (or Dresser Micro Modem) must be installed between a PC in a non-hazardous area and the MC in the hazardous area.

The temperature probe is only suitable for use at atmospheric pressure and therefore must be used in conjunction with a thermowell which is capable of withstanding the line pressure.

All individual wires connected to the circuit board must have at least 0.25mm (1/100 ins) of insulation.

5.3 EMC Compatibility

To ensure that the performance specifications are not significantly affected by electromagnetic interference, it is essential that:

All conductors are adequately shielded using braided screens and that these screens are terminated as recommended in this manual.

Except where stated otherwise, the length of external connections should not exceed 3m (9.57ft).

If equipment which is not approved by the manufacturer (Dresser) is connected to the MC, it is the operator's responsibility to ensure that this equipment is installed and operated in a manner which will ensure that the system is compliant with the relevant EMC standards.

For protections against static damage, it is essential that anti-static precautions are taken when the MC is opened for installation or maintenance.

5.4 Mechanical Installation

The MC is designed to mount to a vertical surface. The MC mounting holes are tapped M6 and the unit may be mounted on a 1.6mm (1/16 in) panel using the 4 off M6 x 20mm (3/4 ins.) screws supplied. Alternatively, 4 off M4 (6-32 in.) cap head machine screws of a suitable length with nuts can be used for very thick panels. For mounting on a wooded panel or similar surface, 4 off No 6 screws of 25mm (1inch) length may be used. The mounting hole pattern is shown in Figure 3 (*MC Mounting Hole Pattern*).

Please contact your distributor for information regarding mounting the MC to an ID Drive.

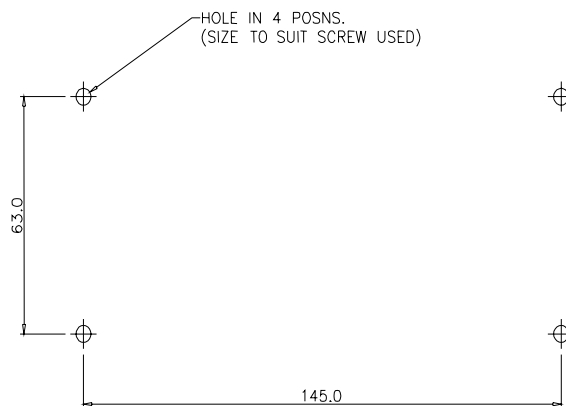

Figure 3 – MC Mounting Hole Pattern

5.4.1 Setting the *Weights and Measures* Link

If operator configuration is required to set up the unit the read / write link will need to be switched to the *Read / Write* position. To set the *Read / Write* link:

1. If the MC is in a hazardous area the setting of the *Weights and Measure* Link should NOT be carried out as the PCB protection plate is removed. The set up procedure should be carried out prior to installation.
2. Remove the 4 screws securing the MC front using the 3mm hexagon wrench (Allen key) supplied. If the 3mm hexagon wrench is not available a 7/64 ins wrench will work but may “cam out” (strip) the head making future loosening and tightening difficult.
3. Lift the front panel forward to expose the PCB protection plate that covers the main circuit board.
4. Remove the 2 PCB protection plate retaining screws (breaking and *Weights and Measures* seal).
5. Identify the *Read / Write* protection link; remove from the *Read Only* position and replace in the *Read / Write* position. Refer to Figure 4 (*Setting the Weights and Measures Link*)
6. The necessary parameter changes should now be carried out via the User Terminal (for further information consult the MC User Terminal Handbook).
7. Once the necessary parameter changes have been uploaded to the unit remove the *Read / Write* link from *Read / Write* position and replace in the *Read Only* position.
8. Replace the 2 PCB protection plate retaining screws. Any required seal must be replaced by the appropriate authority before re-closing the unit. Normally the unit should be set up before sending it to the approval authority for the first time.
9. The MC front panel should be offered up to the case checking that no wiring is trapped between the panel and body.
10. Re-introduce the 4 front panel fixing screws and tighten these a little by hand until all screws are started. Use of anti-seizing compound is recommended.
11. Carefully hold the front panel against the body to form the seal and tighten the 4 securing screws using a 3mm hexagon wrench (Allen key). Ensure that cables are retained within enclosure and not trapped in the lid seal.

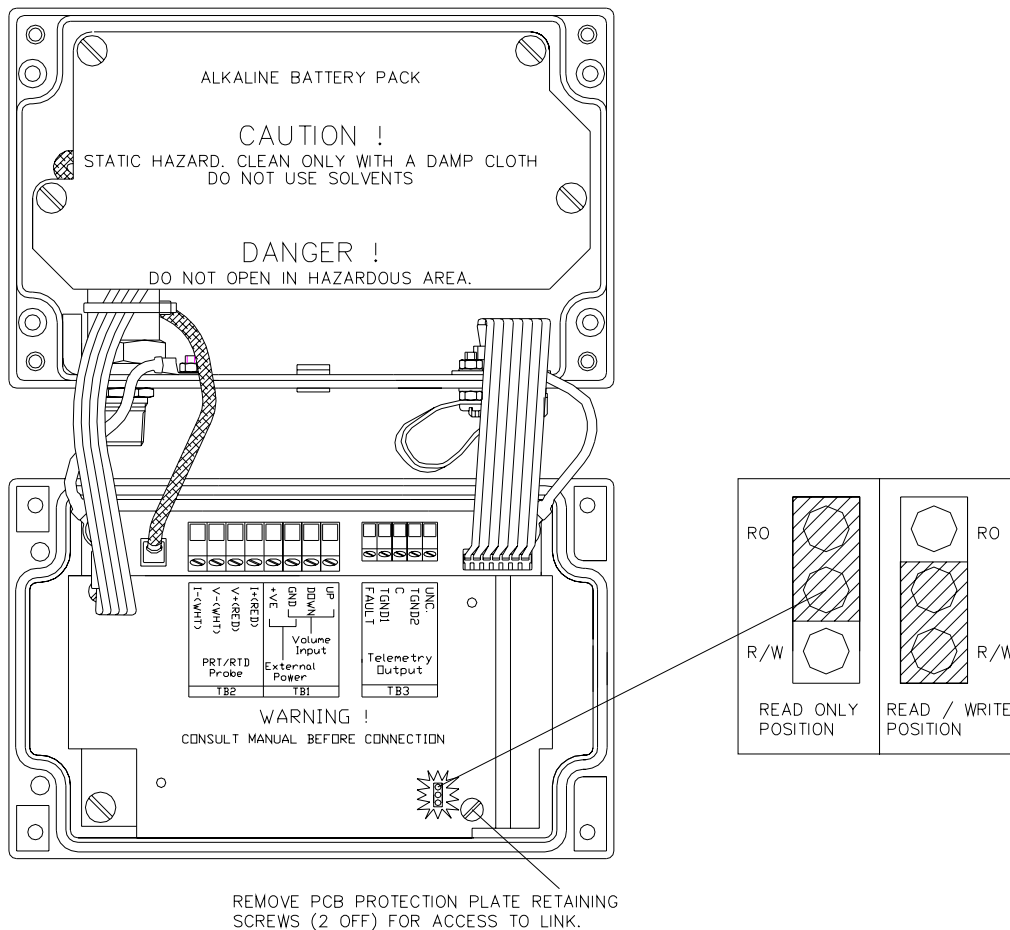

Figure 4 – Setting the *Weights and Measure Link (Hardware Link).*

5.5 *Electrical Installation*

Electrical installation should be performed by a person competent and knowledgeable about installation of intrinsically safe equipment and totally conversant with the National Code of Practice. The person must have undergone formal training on the subject.

For protection against static damage it is essential that anti-static precautions are taken when the MC is opened for installation or maintenance.

5.5.1 Location of the Connection Terminals

When the MC case is opened, the location of the connections terminals will appear as in Figure 5 (*Location of the Connection Terminals*):

1. Remove the 4 screws securing the MC front using the 3mm hexagon wrench (Allen key) supplied. If the 3mm hexagon wrench is not available a 7/64 ins wrench will work but may “cam out” (strip) the head making future loosening and tightening difficult.
2. Lift the front panel forward to expose the PCB protection plate/
3. Carry out the electrical installation as required (refer to sections [5.5.1.1 \(Volume Input \(TB1\)\)](#), [5.5.1.2 \(Temperature Measurement \(TB2\)\)](#) and [5.5.1.3 \(Telemetry Output \(TB3\)\)](#)), and once complete the MC front panel should be replaced and secured:
4. The MC front panel should be offered up to the case checking that no wiring is trapped between the panel and body.
5. Re-introduce the 4 front panel fixing screws and tighten these a little by hand until all screws are started. Use of anti-seizing compound is recommended.

Note: If the case is to be wired and sealed by the *Weights and Measures* authority, the 4 spacers supplied should be fitted under each head of the lid securing screws so that the wiring holes are accessible when the screws are fully tightened.

6. Carefully hold the front panel against the body to form the seal and tighten the 4 securing screws using a 3mm hexagon wrench (Allen key). Ensure that cables are retained within enclosure and not trapped in the lid seal.

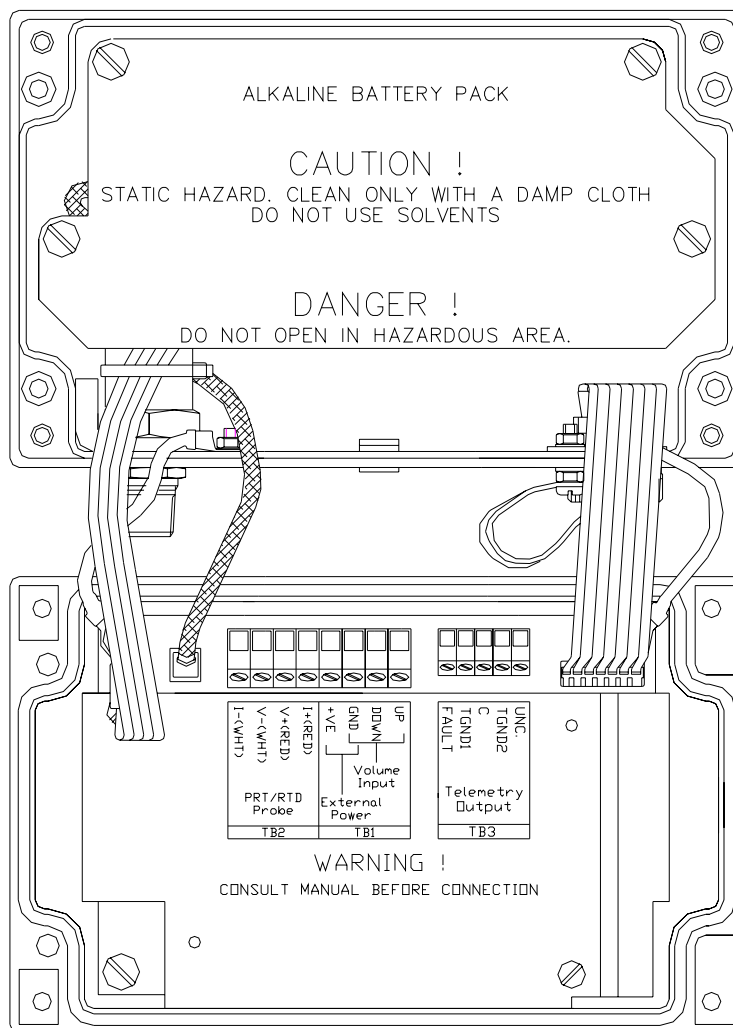

Figure 5 – Location of the Connection Terminals

5.5.1.1 Volume Input (TB1)

The source of the volume input should be connected to the *GND* and *W2/REED* Volume Input terminals of *TB1*, as shown in Figure 6 (*Volume Input (TB1) Connections*).

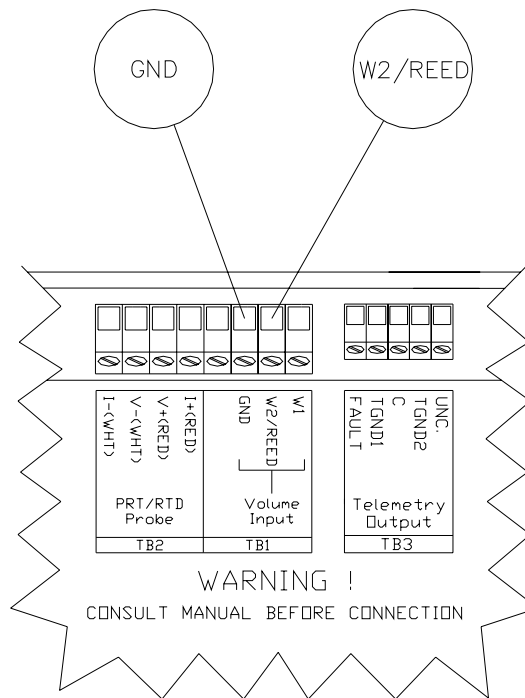

Figure 6 – Volume Input TB1 Connections

5.5.1.2 Temperature Measurement (TB2)

The temperature measurement is accomplished via a temperature probe. Current is injected through a pair of connections and the voltage measured across the other pair.

The wires should be connected to the *PRT/RTD Probe* terminals of *TB2*, as shown in Figure 7 (*Temperature Transducer Connections*).

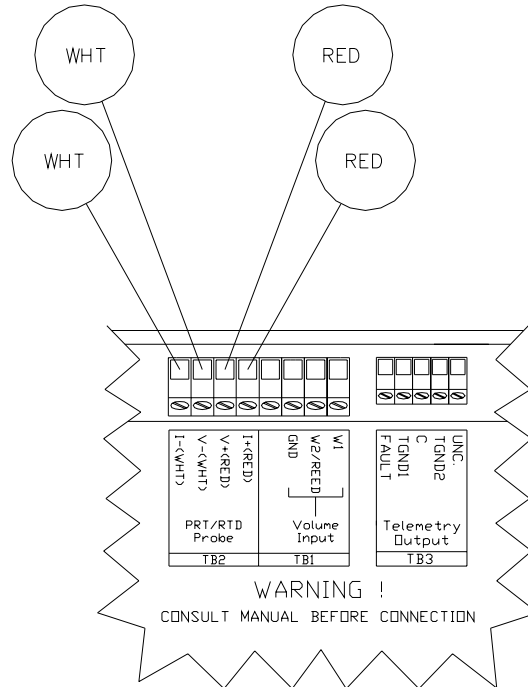

Figure 7 – Temperature Transducer Connections (TB2)

If an alternative sensor is used the wire colours may differ but there should be 2 pairs of wires which are essentially connected directly together inside the probe. A wire from each pair must be connected to the “I” terminals and the other wire from the same pair to the corresponding “V” terminal.

5.5.1.3 Telemetry Output (TB3)

Figure 8 (*Telemetry Output Connection (TB3)*) shows the connections for the telemetry output. Other Dresser approved product, such as the Chatterbox (isolation unit) may be connected to the telemetry outputs. Any equipment connected to the telemetry output must be individually assessed to ensure that the system is safe. Connection to intrinsically safe equipment not detailed in the system drawing (see [Figure 2 \(Intrinsic Safety System Diagram for EECS Compliance\)](#)) must be properly assessed by the user and the manufacturer (Dresser) will not take responsibility for the overall safety of the system.

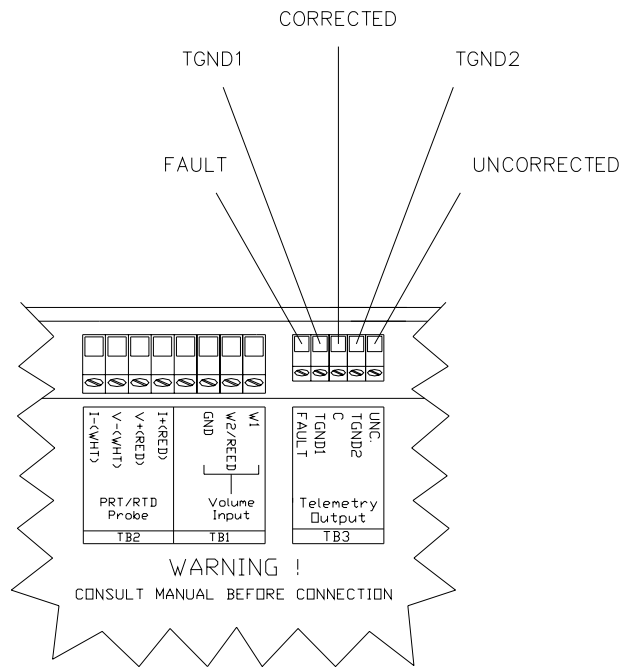

Figure 8 – Telemetry Output Connections (TB3)

6. Maintenance

There is no requirement for routine maintenance of the MC. A pressure check may be performed by applying a known test pressure to the pressure transducer and reading the pressure value from the front panel display of the MC. The error as a percentage of reading should be calculated as follows:

$$100 \times ((P_{\text{ind}} - P_{\text{true}}) / P_{\text{true}})$$

Where P_{ind} is the indicated pressure reading on the display and P_{true} is the known measured pressure. Any difference should be less than 0.7% or such other value defined by local *Weights and Measures* requirements (for P_{true} higher the 20% of full scale). If this value is exceeded the MC should be returned to the distributor so that the cause of the inaccuracy may be investigated. For further details refer to section [6.2 \(Pressure Transducer Recalibration\)](#).

The temperature calibration may also be performed by immersing the temperature probe into a container of liquid of a known temperature. For further details refer to section [6.3 \(Temperature Transducer Recalibration\)](#).

6.1 Replacing the Battery Pack

If the low battery indication is active, the battery pack should be changed within the next 2 months.

MC's should not be left with discharged packs inside them as discharged cells are more prone to leak than are new or partially used cells. If the MC is to be stored for any length of time, the battery pack should be removed and stored separately.

If the internal battery voltage is low, the battery icon will be displayed when the front panel button is pressed. The icon will be present until display test is selected or the default corrected total display is set or the battery voltage rises above the low threshold. Note: The low battery fault latch will only be set when the battery voltage has been low for 24 consecutive hours.

Please contact your distributor for a replacement battery pack.

Before replacing the battery pack press the front panel selector button on the MC. This operation ensures that the latest corrected and uncorrected totals are stored in the permanent memory of the MC. A super capacitor will maintain normal operation of the unit during battery replacement.

For protection against static damage, it is essential that anti-static precautions are taken when the MC is opened.

The battery pack affects the intrinsic safety of the MC and must be replaced with the correct Dresser battery pack. To replace the battery pack:

1. Press the front panel selector button on the front of the MC.
2. Unscrew the 4 screws retaining the front panel of the MC using a hexagon wrench or suitable Allen key (as described in section [5.5 Electrical Installation](#)).
3. Unplug the battery connector from the main circuit board mounted behind the front panel.
4. Use a normal slotted screw driver to remove the 4 screws holding the battery pack.
5. Remove the old battery pack.
6. Place the new battery pack in to position and replace the 4 screws.
7. Plug the new battery pack into the main circuit board, such that the battery plug engages correctly with the connector locking ramp on the circuit board.
8. Check that the MC displays the default parameter of the LCD and the normal operation has resumed.
9. Carefully dress the battery lead and the other wirings so that they will not be trapped between the enclosure and front panel.
10. Replace and retighten the screws holding the front panel as described in section [5.4 Mechanical Installation](#).

Note: The battery pack contains alkaline manganese cells. Observe any local regulations on disposal of this type of battery.

6.2 Pressure Transducer Recalibration

Recalibration of the pressure transducer should not be required however, the MC may be pressure calibrated by the operator, using the serial port of the MC and the User Terminal software. It is possible to calibrate either the zero only or both the zero and the span.

Note: During the pressure calibration process multiple temperature readings are automatically compared over a period to ensure that the readings are stable. If stability is not obtained the calibration process will not be successful.

For further details regarding the pressure calibration refer to the MC User Terminal Handbook, alternatively contact your distributor.

6.3 *Temperature Transducer Recalibration*

Temperature recalibration should not be required however, the MC may be temperature calibrated by the operator, using the serial port of the MC and the User Terminal software.

To obtain temperature calibration points use one of the following methods:

Use temperature controlled baths with the MC temperature probe and a calibrated thermometer for determining the bath temperatures. As an alternative use a vacuum flask filled with liquid which is well stirred, and place the temperature probe and calibrated thermometer in this.

OR

Simulate the temperature probe using a calibrated resistance box set to values corresponding to 2 different temperatures. If this option is chosen the temperature probe must be disconnected from the MC and the resistance box must be connected as a 4 wire resistor in its place.

Note: During the temperature calibration process multiple temperature readings are automatically compared over a period to ensure that the readings are stable. If stability is not obtained the calibration process will not be successful.

For further details regarding the temperature calibration refer to the MC User Terminal Handbook, alternatively contact your distributor.

6.4 *Restoring Factory Defaults*

It is possible to restore the factory defaults for pressure and temperature from within the User Terminal. For further details consult the MC User Terminal Handbook, alternatively contact your distributor.

6.5 *Service*

There are no user replaceable parts with the exception of the temperature probe and the battery pack.

Repair of the circuit board itself should not be attempted as this may invalidate I.S. approval of the product.

7. Appendix A – Ordering Information

7.1 Model Part Number Formulation

The MC is available in several models, and the part number is made to reflect these models. The part number format is detailed in Figure 9 (*Model Part Number Formulation Guide*).

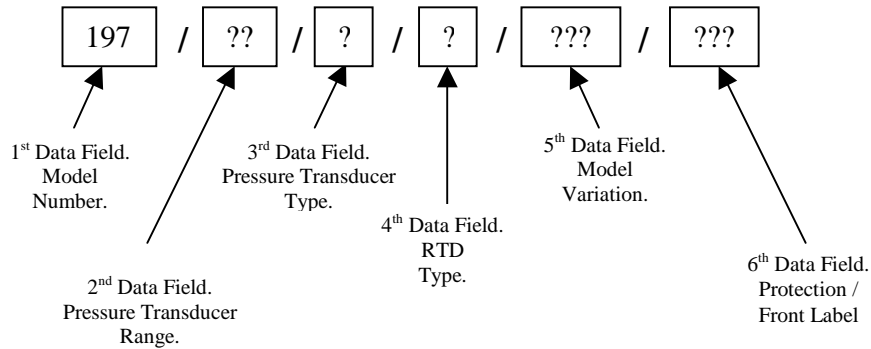

Figure 9 – Model Part Number Formulation Guide

Table 4 (*Model Part Number Formulation Reference Table*) identifies the various codes representing the various MC forms. This can be used to identify the specific requirements of the model type of MC identified previously.

7.2 Worked Examples

7.2.1 Example 1

Customer A would like to order a 12 Bar absolute MC with data logging and a 3 meter non-armoured temperature probe. The unit should be hardware link protected with an English language label. The required part number is built as follows:

Model number	See table 4 – 1 st data field	197
Pressure Transducer Range	See table 4 – 2 nd data field	12
Pressure Transducer Type	See table 4 – 3 rd data field	A
RTD Type	See table 4 – 4 th data field	0
Model Variation	See table 4 – 5 th data field	PTZL
Protection / Front label	See table 12 – 6 th data field	EU

The part number that Customer A should order: **197/12/A/0/PTZL/EU**

7.2.2 Example 2

Customer B would like to order a 2 Bar gauge MC, with data logging and a 1.5 meter armoured temperature probe. The unit should be password protected with a USA label. The required part number is built as follows:

Model number	See table 4 – 1 st data field	197
Pressure Transducer Range	See table 4 – 2 nd data field	12
Pressure Transducer Type	See table 4 – 3 rd data field	G
RTD Type	See table 4 – 4 th data field	2
Model Variation	See table 4 – 5 th data field	PTZL
Protection / Front label	See table 4 – 6 th data field	US

The part number that Customer B should order: **197/12/G/2/PTZL/US**

Table 4 – Model Part Number Formulation Reference Table

Data Field	Options	Part No. Code
1 st Data Field Model Number?	MC	197
2 nd Data Field Pressure Transducer Range?	T-Only (no pressure transducer) 2.0 Bar 12.0 Bar 24.0 Bar 30.0 Bar* 70.0 Bar* *Available in Absolute transducers only.	00 02 12 24 30 70
3 rd Data Field Transducer Type?	Absolute Gauge	A G
4 th Data Field RTD Type?	6.0 Non Armoured 10ft Armoured cable 9" Armoured 1.5m Non Armoured 1.5m Armoured 3.0m Armoured 3.0m Non Armoured ID Mount ID Mount with Counter Not Required	9 7 6 4 2 1 0 I C N
5 th Data Field Model Variation	Pressure, Temperature, Supercompressibility (Z), & Log Temperature Log	PTZL TLOG
6 th Data Field Configuration / Front Label?	Hardware link protected (<i>Weights and Measures</i> Protection) / English Label Password protected / USA Label Hardware link protected (<i>Weights and Measures</i> Protection) / USA Label	EU US EUS