

# Style 31 Line Caps

For close-off, testing and capping “dead-ends” for future branch extensions

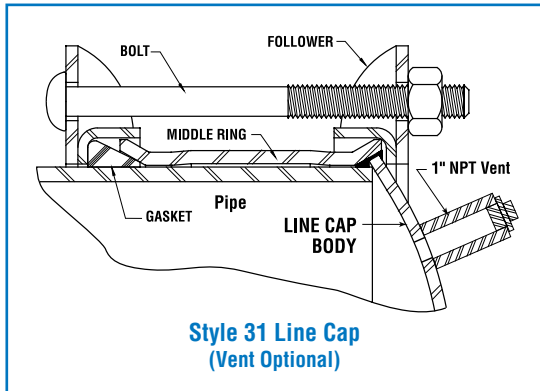

Style 31 Line Cap  
(Vent Optional)

Dresser Style 31 Line Caps are used to close off sections of a pipeline during construction and testing, and to cap off dead-ends in the line for future branch connections. Style 31 Line Caps are made from Style 38 Dresser coupling parts with a convex steel dished head welded into one end of the middle ring. One follower ring is welded to the cap itself, and only one gasket is required.

The Style 31 is regularly supplied with a 1" NPT vent and plug off-center. When ordering, please specify whether vent is to be provided.

The Dresser Style 31 Line Cap is also available in an insulating design with insulating gasket, insulating sleeve and pipe-end separator.

**WARNING: Style 31 Line Caps must NOT be used under pressure WITHOUT ANCHORAGE OR BLOCKING sufficient to withstand the entire longitudinal thrust due to internal pressure.**

## Materials of Construction

**Followers:** AISI C1012 or ASME SA36  
(Ductile Iron or Malleable Iron for 1/2" thru 1-1/2")

**Middle Ring:** ASTM A513, ASTM A635 or ASME SA675 GR60

**Bolts:** AWWA C 111/ANSI A21.11

**Gasket:** Grade 27 BUNA S (Armored)

**NOTE: See inside back cover for Style 1031 Line Cap Plugs**

## Style 31 Line Caps

### Sizes and Specifications for Steel Pipe

Pipe Nominal Size (ID)	Outside Pipe Diameter (OD)	Middle Ring Thickness & Length (A&B)	Bolts No./Diam. x Length (D&E)	Working* Pressure Lbs. per Sq.In.	Approx. Weight Each (Lbs.)
2	2.375	.187 x 5	3-5/8 x 8-1/4	150	12
3	3.500	.188 x 5	4-5/8 x 6	150	12
4	4.500	.188 x 5	4-5/8 x 6	150	18
6	6.625	1-1/4 x 5	6-5/8 x 6	150	30
8	8.625	1-1/4 x 5	6-5/8 x 6	150	37
10	10.750	1-1/4 x 5	8-5/8 x 6	150	39
12	12.750	1-1/4 x 5	8-5/8 x 6	150	47
14	14.000	1-1/4 x 7	10-5/8 x 10-3/4	150	73
16	16.000	1-1/4 x 7	10-5/8 x 10-3/4	150	86
18	18.000	1-1/4 x 7	12-5/8 x 10-3/4	150	98
20	20.000	3/8 x 7	12-5/8 x 10-3/4	150	113
24	24.000	3/8 x 7	15-5/8 x 10-3/4	150	187

### Sizes and Specifications for Cast-Iron Pipe

Pipe Nominal Size (ID)	Outside Pipe Diameter (OD)	Middle Ring Thickness & Length (A&B)	Bolts No./Diam. x Length (D&E)	Working* Pressure Lbs. per Sq.In.	Approx. Weight Each (Lbs.)
2	2.500	.187 x 5	3-5/8 x 8-1/4	150	12
3	3.800	.188 x 5	4-5/8 x 8-1/4	150	14
3	3.960	.203 x 5	4-5/8 x 8-1/4	150	18
4	4.800	.229 x 5	4-5/8 x 8-1/4	150	22
4	5.000	.229 x 5	4-5/8 x 8-1/4	150	23
6	6.900	1/4 x 5	6-5/8 x 8-1/4	150	32
6	7.100	1/4 x 5	6-5/8 x 8-1/4	150	37
8	9.050	1/4 x 5	6-5/8 x 8-1/4	150	42
8	9.300	1/4 x 5	6-5/8 x 8-1/4	150	45
10	11.100	3/8 x 7	8-5/8 x 10-3/4	150	71
10	11.400	3/8 x 7	8-5/8 x 10-3/4	150	72
12	13.200	3/8 x 7	8-5/8 x 10-3/4	150	100
12	13.500	3/8 x 7	8-5/8 x 10-3/4	150	106
14	15.300	3/8 x 7	10-5/8 x 10-3/4	150	120
14	15.650	3/8 x 7	10-5/8 x 10-3/4	150	124
16	17.400	3/8 x 7	10-5/8 x 10-3/4	150	136
16	17.800	3/8 x 7	10-5/8 x 10-3/4	150	147
18	19.500	3/8 x 7	12-5/8 x 10-3/4	150	163
18	19.920	3/8 x 7	12-5/8 x 10-3/4	150	167
20	21.600	3/8 x 7	12-5/8 x 10-3/4	150	183
20	22.060	3/8 x 7	14-5/8 x 10-3/4	150	192
24	25.800	3/8 x 7	15-5/8 x 10-3/4	150	230
24	26.320	3/8 x 7	15-5/8 x 10-3/4	150	235

**NOTE: All Style 31 Line Caps supplied with 1" vents as standard. Larger sizes are available. Consult factory for your particular requirements. \*Higher pressures available per application.**