

Style 128 Flange Adapter

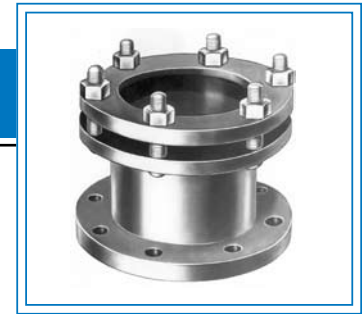

Fabricated to order from high-strength steel, **Dresser Style 128 Flange Adapters** afford the engineer a complete size range up to 24" diameter in steel and cast-iron sizes. ANSI B16.5 Class 150 flanges are standard. Other types and classes can be provided on request.

The compression end of the adapter has a Dresser coupling type design utilizing a wedge gasket for an efficient, leak-proof seal. Insulating designs can also be furnished. Larger sizes up to 96" are available upon request.

Materials of Construction

Follower: AISI C1012 or ASME SA36

Body & Flange: ASTM A513, ASTM A635 or ASME SA675 GR60

Bolts & Nuts: Alloy to AWWA C 111/ANSI A21.11

Gasket: Grade 27 BUNA S

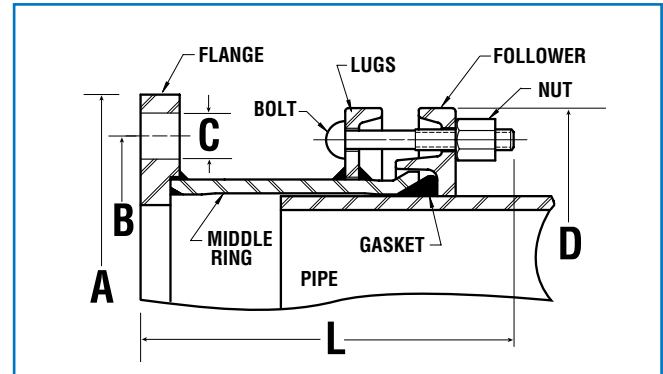

Style 128 Flange Adapter* Sizes and Specifications for Steel Pipe

Nominal Size (Steel)	Outside Diameter (Inches)	Body Thickness	Follower End Bolts Number Diam. & Length	Overall Flange Diameter (A)	Bolt Circle Diameter (B)	No. of Bolt Holes x Diameter (C)	Overall Follower Diameter (D)	Approx. Overall Length (L)	Approx. Shipping Weight (Lbs)
2	2-3/8	.156	3-5/8 x 4	6	4-3/4	4 x 3/4"	6-1/4	8-5/8	14
3	3-1/2	.156	4-5/8 x 4	7-1/2	6	4 x 3/4"	7-3/8	8-13/16	19
4	4-1/2	.188	4-5/8 x 4	9	7-1/2	8 x 3/4"	8-3/4	8-13/16	25
5	5-9/16	1/4	4-5/8 x 4	10	8-1/2	8 x 7/8"	9-5/8	9-9/16	30
6	6-5/8	1/4	6-5/8 x 4	11	9-1/2	8 x 7/8"	11-1/4	9-5/8	38
8	8-5/8	1/4	6-5/8 x 4	13-1/2	11-3/4	8 x 7/8"	13-1/4	9-3/4	52
10	10-3/4	1/4	8-5/8 x 4	16	14-1/4	12 x 1"	14-5/8	9-13/16	58
12	12-3/4	1/4	8-5/8 x 4	19	17	12 x 1"	16-5/8	9-7/8	79
	14	1/4	8-5/8 x 4	21	18-3/4	12 x 1-1/8"	18	10	89
	16	3/8	10-5/8 x 4	23-1/2	21-1/4	16 x 1-1/8"	20	10-1/16	103
	18	1/4	10-5/8 x 4-1/2	25	22-3/4	16 x 1-1/4"	22	10-11/16	112
	20	3/8	12-5/8 x 4-1/2	27-1/2	25	20 x 1-1/4"	24-1/16	10-13/16	127
	24	3/8	14-5/8 x 4-1/2	32	29-1/2	20 x 1-3/8"	28	11	184

Style 128 Flange Adapter* Sizes and Specifications for Cast-Iron Pipe

Nominal Size (CIP)	Outside Diameter (Inches)	Body Thickness	Follower End Bolts Number Diam. & Length	Overall Flange Diameter (A)	Bolt Circle Diameter (B)	No. of Bolt Holes x Diameter (C)	Overall Follower Diameter (D)	Approx. Overall Length (L)	Approx. Shipping Weight (Lbs)
3	3.74 - 4.02	.188	4-5/8 x 4	7-1/2	6	4 x 3/4"	7-3/4	8-11/16	25
4	4.74 - 5.06	.229	4-5/8 x 4	9	7-1/2	8 x 3/4"	9	9-7/16	30
6	6.84 - 7.16	1/4	4-5/8 x 4	11	9-1/2	8 x 7/8"	11-3/16	9-1/16	36
8	8.99 - 9.36	1/4	6-5/8 x 4	13-1/2	11-3/4	8 x 7/8"	13-1/2	9-1/16	50
10	11.04 - 11.46	3/8	8-5/8 x 4	16	14-1/4	12 x 1"	15-9/16	9-3/16	69
12	13.14 - 13.56	3/8	8-5/8 x 4-1/2	19	17	12 x 1"	17-13/16	9-11/16	95

*Rated 150 psi as standard