

## 2" Standard Single Port

Flangeless CL 150 – 600



**2" Standard Single Port Flangeless Flowgrid® Valve with Series 20 Pilot**

### SECTIONAL VIEW

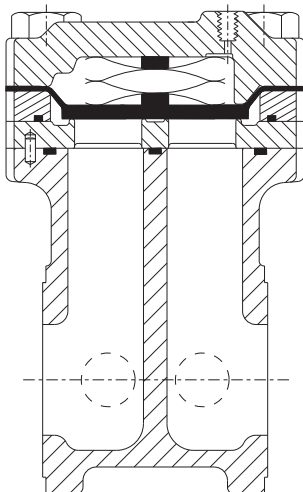

### OVERPRESSURE PROTECTION

The Flowgrid® Valve is bi-directional and has a full ANSI rating on both the inlet and outlet. Overpressure protection is required only if the pressure can exceed the flange or body rating.

The pilots, like most regulators, may have an outlet pressure rating lower than the inlet pressure rating. If this is the case then some external form of overpressure protection must be provided for the pilot.

Anytime the Flowgrid® valve or pilot system is exposed to pressure in excess of its rating it should be inspected for damage.

The 2" Standard Single Port Flangeless Flowgrid® Valve is an economical and easy to maintain pilot operated valve for both gas and liquid applications. This space saving valve has a face to face dimension of only 4.187". this dimension is the same as the obsolete REDQ™ Model 82 and current Model 83 making the Flowgrid® Valve an ideal replacement. The valve can be converted into a 2" Large Single Port for extra capacity simply by changing the Spring Case, Diaphragm, Spacer, and Throttle Plate.

### SPECIFICATIONS

<b>Size</b>	2"
<b>Body Style</b>	Standard Single Port (2")
<b>End Connections</b>	2" CL150, 300, 600 Flangeless
<b>Temperature</b>	Working -20°F to 150°F Emergency -40°F to 175°F
<b>Max. Operating Differential</b>	800 psi
<b>Max. Emergency Differential</b>	1000 psi
<b>Min. Differential</b>	Refer to graph on page 2
<b>Cracking Differential</b>	Refer to graph on page 2
<b>Max. Inlet Pressure</b>	1480 psig*
<b>Outlet Pressure Range</b>	Limited By Pilot
<b>Flow Direction</b>	Bi-Directional**
<b>Body Taps</b>	Two 1/4" - 18NPT

\* Limited by pilot or flange rating

\*\* Reverse flow by changing pilot connections and reversing spring case

### MATERIALS OF CONSTRUCTION

<b>Body &amp; Spring Case</b>	ASTM A 216 GR WCB Carbon Steel
<b>Throttle Plate</b>	17 - 4PH Stainless Steel or A515 Carbon Steel with ENC Coating
<b>Diaphragm</b>	Nitrile/Nylon*
<b>O-Ring &amp; Seals</b>	Nitrile, Optional (Viton)
<b>Bolting</b>	ASTM A 193 GR B-7 or Equal
<b>Spring</b>	301 Stainless Steel

\*Refer to diaphragm selection chart on page 2

### STOCK NUMBERS

2" Std Single Port Flangeless	Stock #	Weight
<b>150# Flangeless</b>	FG-15	29 lbs.
<b>300# Flangeless</b>	FG-15	29 lbs.

## DIMENSIONS

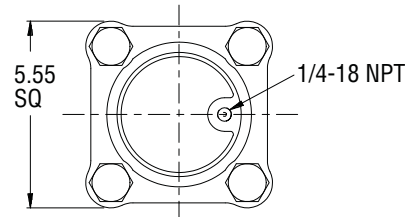
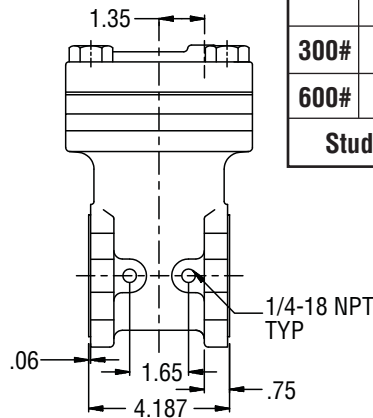
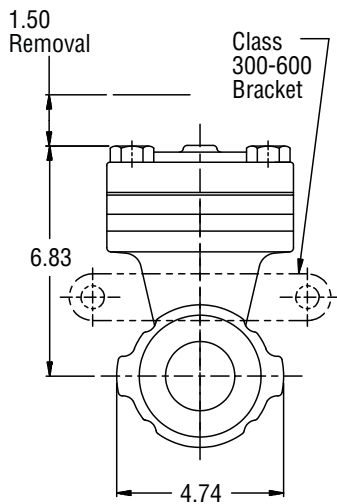

Class	Bolt Circle	Bolt Size	Quantity	Stud Length	Bracket Stud Length	Quantity
150#	4.75	5/8-11UNC	4	8.50	Not Required	Not Required
300#	5.00	5/8-11UNC	6	8.50	11.0	2
600#	5.00	5/8-11UNC	6	8.50	11.0	2

**Stud Material: A193 Grade B7    Nut Material: A194 Grade 2H**

## FLOW COEFFICIENTS AND CONSTANTS

2" Standard Single Port Flangeless Valve				Swage Factor	
Percent Capacity	Cv	C1	Cg	1.5:1	2:1
100%	32	35	1120	0.98	0.97
75%	27	30	827	0.99	0.98
50%	23	27	620	1.00	0.98
35%	13	26	338	1.00	1.00

**NOTE:** Allow a 5% factor of safety when calculating relief capacity

## MINIMUM PRESSURE DIFFERENTIAL VS. CAPACITY

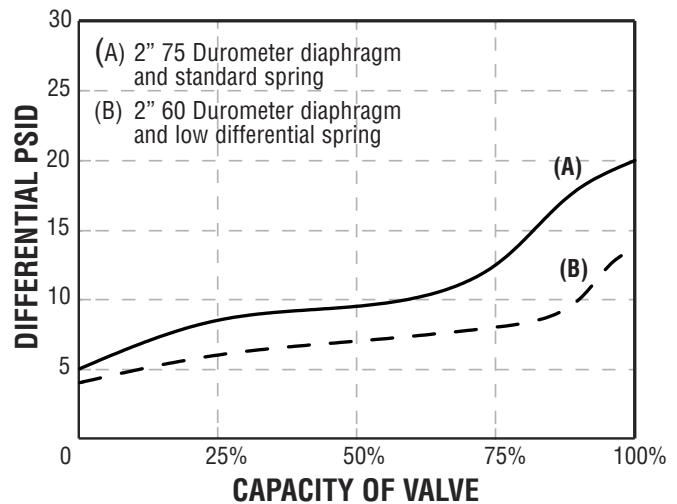

## DIAPHRAGM SELECTION

Compound	Temp. Range (Degrees F)	Maximum Differential	Characteristics	Recommended Applications
75 Duro	-20 to 150	1000 psid	Best All Around Material	60 psid to Max. Differential
60 Duro	-25 to 150	300 psid	Best Shutoff at Low Differential Pressure	Low Differential (100 psid or less) or Low Temperature
80 Duro High ACN	-5 to 175	1000 psid	Higher Abrasion and Swelling Resistance	High Differential (400 psid or higher) or Abrasive Conditions with Distillates
80 Duro Low ACN	-20 to 150	1000 psid	Higher Abrasion Resistance and Low Temperature Flexibility	High Differential (400 psid or higher) or Abrasive Conditions at Low Temperatures

**Mooney  
Dresser, Inc.**  
2822 S. 1030 W.  
Salt Lake City, Utah 84119  
Phone: 801.487.2225 Fax: 801.487.2587  
www.mooneycontrols.com

