

2" Added Capacity Port

Flanged CL 150, 300 & 600
NPT & SWE CL 600

The 2" x 3" Flowgrid® Valve is an economical and easy to maintain pilot operated valve for both gas and liquid applications. The valve is designed to be used in conjunction with a self contained pilot control system as pictured. This valve combines a 2" body with a 3" port producing a very strong piping installation with low regulator outlet velocity. It is ideal for skid mounted, vault and enclosure installations.

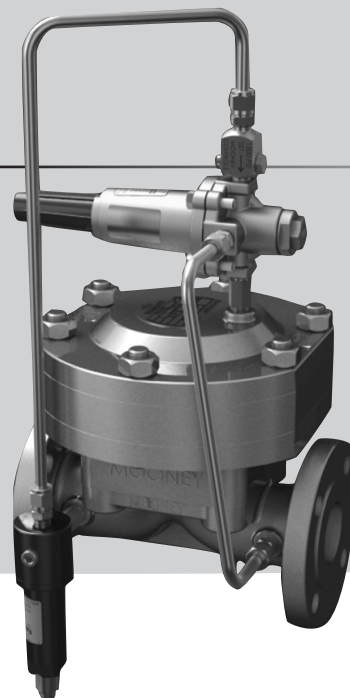

Specifications

Size	2"
Body Style	Single Port (2")
End Connections	2" CI 150, 300, 600 Flanged 2" CI 600 NPT, SWE
Temperature	Working -20°F to 150°F Emergency -40°F to 175°F
Maximum Operating Differential	800 psig
Maximum Emergency Differential	1000 psig
Minimum Differential	Refer to Graph on pg 2
Cracking Differential	Refer to Graph on pg 2
Maximum Inlet Pressure	1480 psig*
Outlet Pressure Range	Limited by Pilot
Flow Direction	Bi-Directional**
Body Taps	Two 1/4" - 18 NPT

* Limited by pilot or flange rating

** Reverse flow by changing pilot connections and reversing spring case

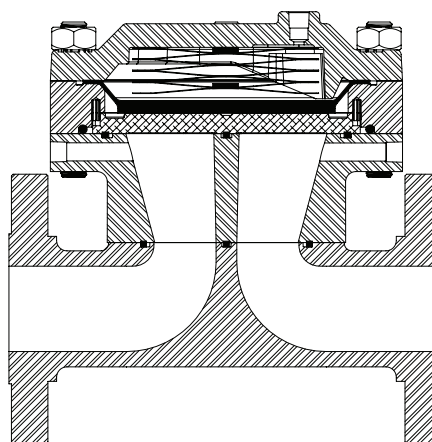

Sectional View

Stock Numbers

2" x 3" Adapter	Stock Number	Weight
150 # Flange	FG-119	78 lbs
300# Flange	FG-120	82 lbs
600# Flange	FG-121	88 lbs
NPT CL 600	FG-117	68 lbs
SWE CL 600	FG-118	68 lbs

Materials of Construction

Body & Spring Housing	ASTM A 216 GR WCB Carbon Steel
Throttle Plate	17 - 4PH Stainless Steel or A515 Carbon Steel with ENC Coating
Diaphragm	Nitrile/Nylon*
O-Ring & Seals	Nitrile
Bolting	ASTM A 193 GR B-7 or Equal
Spring	301 Stainless Steel

* Refer to diaphragm selection chart on page 2

Dimensions

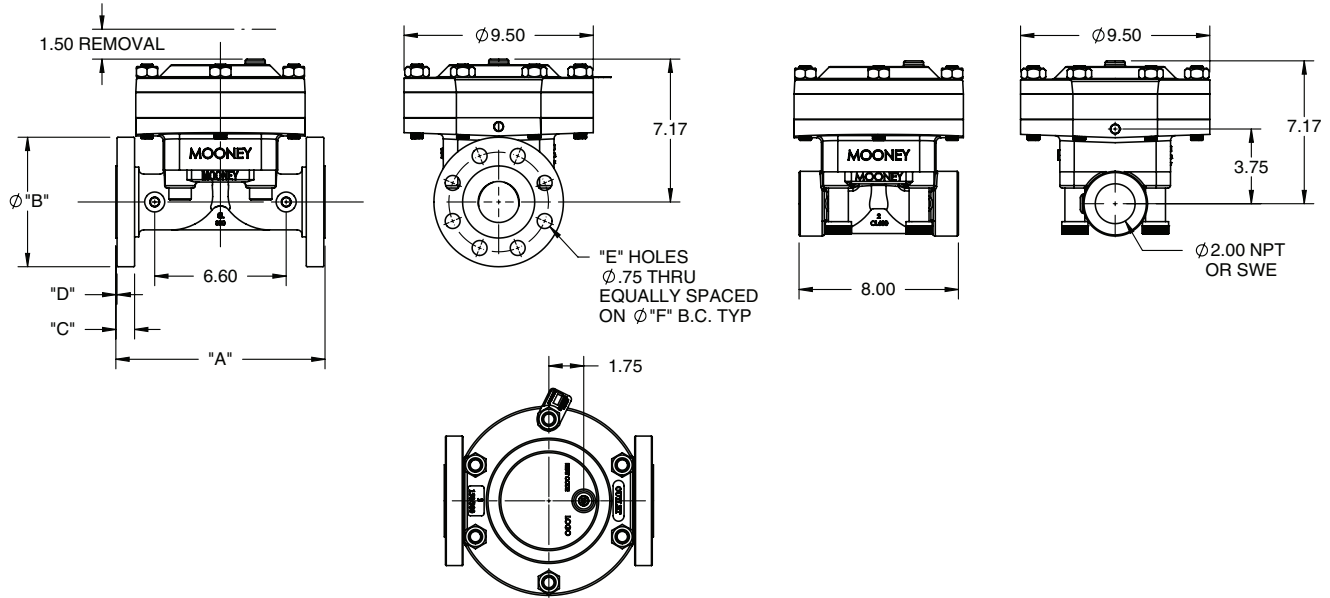

Flange Dimensions

Flange Class	A	B	C	D	E	F
Class 150	10.00	6.00	.75	.06	4	4.75
Class 300	10.50	6.50	.88	.06	8	5.00
Class 600	11.25	6.50	1.25	.25	8	5.00

Flow Coefficients and Constants

Percent	2" Added Capacity Single Port			Swage Factor	
	C_v Preliminary	C_1	C_g	1.5:1	2:1
100%	56	35	1970	0.96	0.93

* Preliminary data

Minimum Pressure Differential vs. Capacity

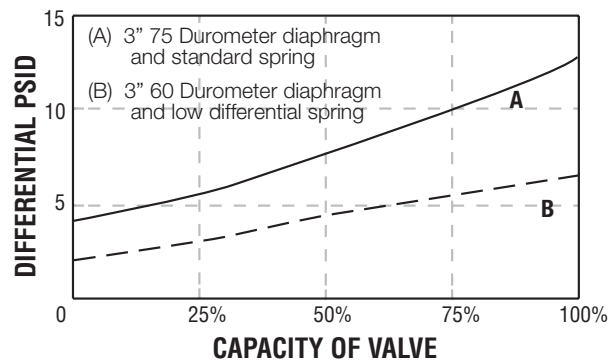

* Preliminary data

Diaphragm Selection

Compound	Temp. Range (Degrees F)	Maximum Differential	Characteristics	Recommended Applications
75 Duro	-20 to 150	1000 psid	Best All Around Material	60 psid to Max. Differential
60 Duro	-25 to 150	300 psid	Best Shutoff at Low Differential Pressure	Low Differential (100 psid or less) or Low Temperature
80 Duro High ACN	-5 to 175	1000 psid	Higher Abrasion and Swelling Resistance	High Differential (400 psid or higher) or Abrasive Conditions with Distillates
80 Duro Low ACN	-20 to 150	1000 psid	Higher Abrasion Resistance and Low Temperature Flexibility	High Differential (400 psid or higher) or Abrasive Conditions at Low Temperatures

Dresser, Inc.

2822 S. 1030 W.
Salt Lake City, Utah 84119
Phone: 801.487.2225 Fax: 801.487.2587
www.dresser.com/mooney

