

SERIES 20/20S/20H/ 20HS PILOT

Installation, Operation & Maintenance

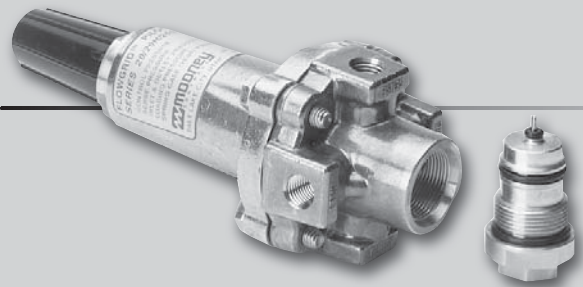

Scope

This manual provides installation, operation and maintenance instructions for the Series 20/20S/20H/20HS Pilots. The manual is divided into the following sections:

Contents

Product Description.....	1	Unloading and Loading Valve Schematics	5
Materials of Construction	2	Installation	5-6
Specifications	2-3	Maintenance.....	6-11
Pilot Markings.....	3	Warranty.....	12
Nameplate Information	3		

Product Description

The SERIES 20 PILOT is a reversible pressure control regulator designed for use on Flowgrid® and FlowMax® valves. It can be used for pressure reducing (PRV), backpressure (BPV or Relief), and differential pressure applications. The Series 20 Pilot is designed for both Gas and Liquid applications.

Series 20 - Brass construction with 3 to 450 PSI control pressure range.

Series 20H - High pressure brass construction with a 200 to 900 PSI control pressure range.

Series 20S - Stainless steel construction with a 3 to 450 control pressure range.

Series 20HS - High pressure, Stainless steel construction with a 200 to 900 PSI control pressure range.

The parts in all constructions are interchangeable. The high pressure constructions (Series 20H and 20HS) differ from the Series 20 and 20S with the addition of a diaphragm spacer assembly that reduces the effective area of the diaphragm and increases the spring range of the black and green springs.

General Description

(Refer to page 2, Figure 1)

Spring Housing (1): The Pilot Spring Housing is provided with a 1/4 inch NPT vent connection which may be piped to a safe area or pressure loaded for remote control of the pressure setting. The Spring Housing may also be pressurized for use in differential pressure control or remote control applications. The Main Spring may be changed by simply removing the Closing Cap (1A).

Body Insert Assembly (2): A removable Body Insert Assembly (Cartridge), at the bottom of the Pilot Body, contains the inner valve mechanism. The inner valve is reversible so that the Main Spring will either open the valve (Pressure Reducing mode) or close the valve (Back Pressure or Relief mode). The cartridge may be replaced with a spare unit for fast trouble shooting or repair. The Body Insert Assembly is also field repairable.

Inlet and Loading Ports (3): The inlet port is common with the loading port through an internal passage in the pilot. A Restrictor is normally connected directly to the inlet port. The loading port is used to connect and mount the pilot to the loading chamber of the valve to be operated.

Sensing Port (4): The Series 20 pilot has separate sensing and outlet (discharge) connections. The sensing connection is “static” which means that there is no flow in the sensing line and the true pipeline pressure is measured at the diaphragm.

Outlet Port (5): The Outlet (discharge) port must be connected to the valve outlet or outlet pressure system. Separate Sensing and Outlet ports make piping easier and facilitates piping working monitor and standby monitor systems using a variety of piping and control schemes.

Diaphragm Spacer Assembly (6): The addition of this assembly converts the Series 20 & 20S Pilot into the high pressure Series 20H & 20HS. It reduces the pilot diaphragm area and increases the spring range of the black and green springs.

NOTE: The pilot is designed for use with an external restrictor (refer to PRINCIPLE OF OPERATION SECTION of this manual). The restrictor may be a needle valve or rotary scratch valve such as the TYPE 24 Flowgrid® Restrictor and would normally be installed in the pilot INLET connection (3).

Table 1

Materials of Construction Series 20 and 20S	
Body & Spring Housing	Forged Brass or 304 Stainless Steel
Body Insert & Closing Cap	Brass or 304 Stainless Steel
Orifice	304 Stainless Steel
Plug & Stem	Nitrile/304 Stainless Steel
Diaphragm	Nitrile/Nylon or Viton/Nylon
O-Rings	Nitrile or Viton

Table 2

Specifications All Series 20 Pilots	
Body Style	Pressure Reducing (PRV) & Back Pressure (BPV)
Orifice Size	0.15 Inches
Connections	1/4" NPTF
Temperature	Working 20° F to 150° F Emergency -40°F to 200°F
Maximum Inlet Pressure	1500 psig
Maximum Loading Pressure	1500 psig
Maximum Outlet Pressure	1500 psig
Maximum Emergency Sensing Pressure	1000 psig
Maximum Spring Housing Pressure	1000 psig
Set Pressure Range	*3-900 psig

*Refer to Table 4 (page 3) for specific spring ranges.

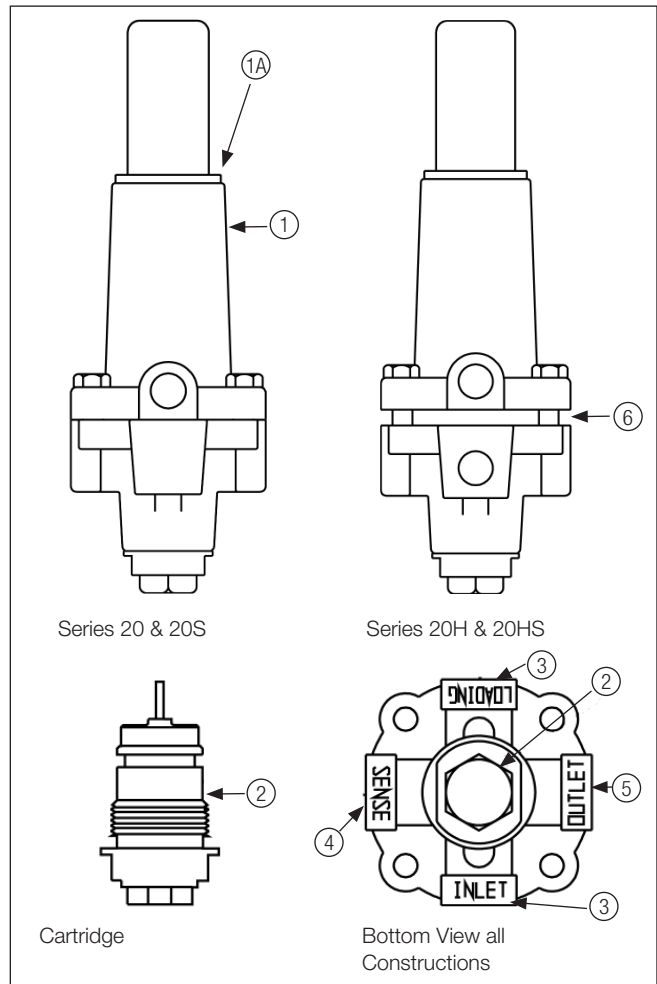

Figure 1

Table 3

Materials of Construction Series 20H & 20HS	
Body & Spring Housing	Forged Brass or 304 Stainless Steel
Body Insert & Closing Cap	Brass or 304 Stainless Steel
Diaphragm Spacer Assembly	304 Stainless Steel
Orifice	304 Stainless Steel or Delrin*
Plug & Stem	Nitrile/304 Stainless Steel Viton/304 Stainless Steel 304 Stainless Steel
Diaphragm	Nitrile/Nylon or Viton/Nylon
O-Rings	Nitrile or Viton

*Delrin Orifice used in High Pressure BPV applications only.

Table 4

Specifications			
Series	Spring Range	Color	Part Number
20 & 20S	3 - 12 psi	Red	040-014-01
	10 - 40 psi	Cadmium	040-011-01
	25 - 90 psi	Blue	040-012-01
	60 - 200 psi	Purple	040-008-01
	100 - 260 psi	Black	040-009-01
	200 - 450 psi	Green	040-020-01
20H & 20HS	200 - 520 psi	Black*	040-009-01
	400 - 900 psi	Green*	040-020-01

*Spacer on Adjustment Screw Required

PILOT MARKINGS

1. Location of the Pilot nameplate.
2. Location of spring range nameplate. The factory marks the nameplate to indicate which spring is installed at manufacture date. If the spring is changed make sure to note it on the nameplate.
3. The month and year the pilot is manufactured is noted on the Spring Case, Body, and Body Insert of the pilot.

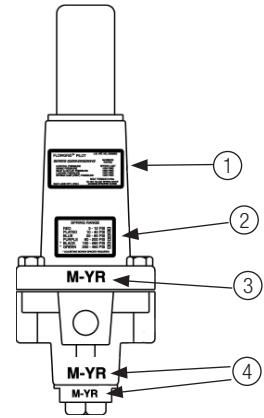

Figure 2

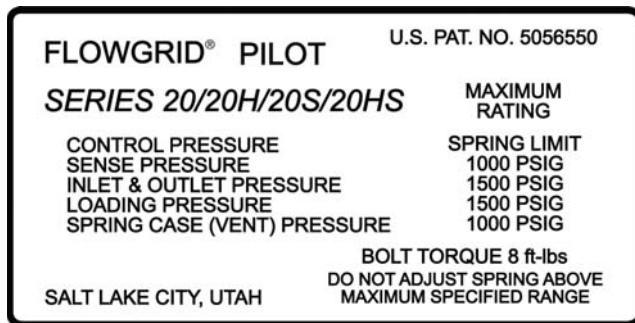

Figure 3 - Nameplate for Series 20, 20H, 20S, & 20HS Flowgrid® Pilots.

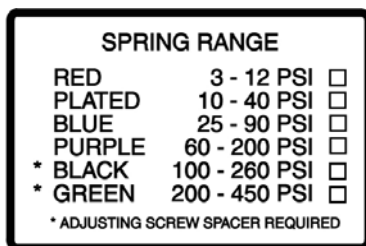

Figure 4 - Spring Range Nameplate for Series 20 & 20S Flowgrid® Pilots.

Item	Definition
Flowgrid® Pilot	Trademarked name of pilot.
SERIES...	Model number of pilot.
Control Pressure	The control pressure is limited to the spring range of the spring on the pilot (Refer to Fig.4 for Series 20 & 20S pilots)
Sense Pressure	Maximum allowable pressure in sense
Inlet & Outlet Pressure	Maximum allowable pressure (psig) to the Inlet and Outlet ports.
Loading Pressure	Maximum allowable pressure (psig) to the Loading port.
Spring Case (Vent) Pressure	Maximum allowable pressure (psig) to the Spring Case (Vent) port.
Bolt Torque	Recommended bolt torque for spring case in foot pounds.
Red, Cadmium, Blue, Purple, Black and Green	Each spring is color coded to indicate the control pressure range
Adjusting...	The black and green springs require a spacer on the adjusting screw to avoid over compression.

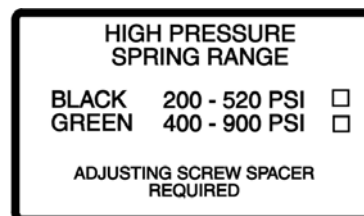
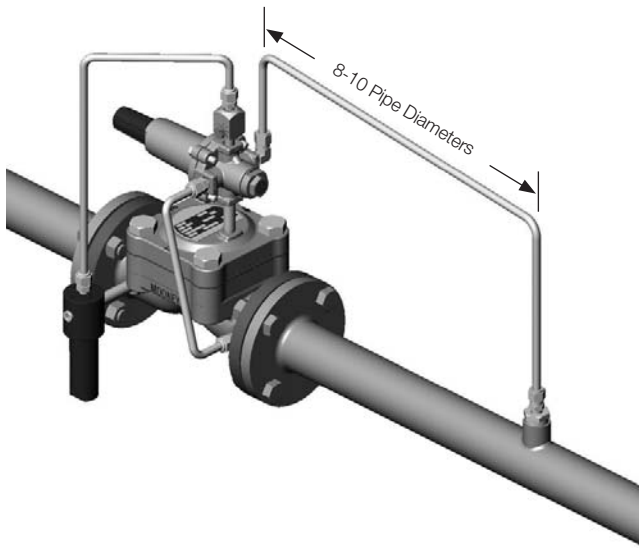
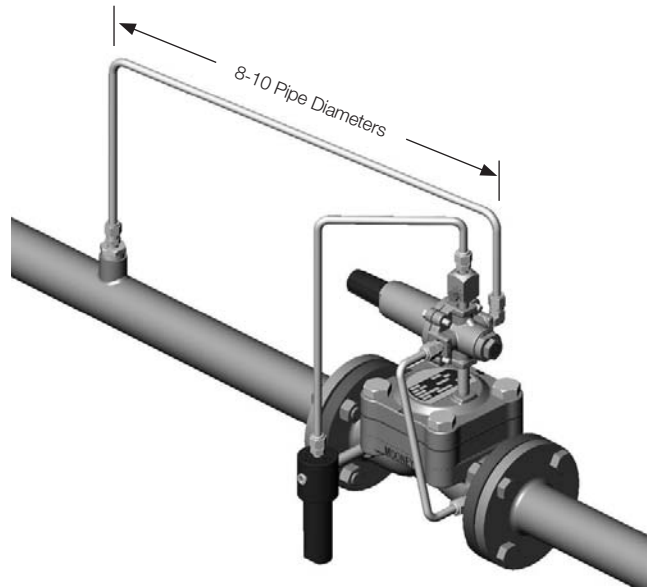

Figure 5 - Spring Range Nameplate for Series 20H & 20HS Flowgrid® Pilots.

Series 20 Pilot – Unloading and loading type valve



Unloading Type Valve
(Pressure Reducing Valve)



Unloading Type Valve
(Back Pressure Valve)

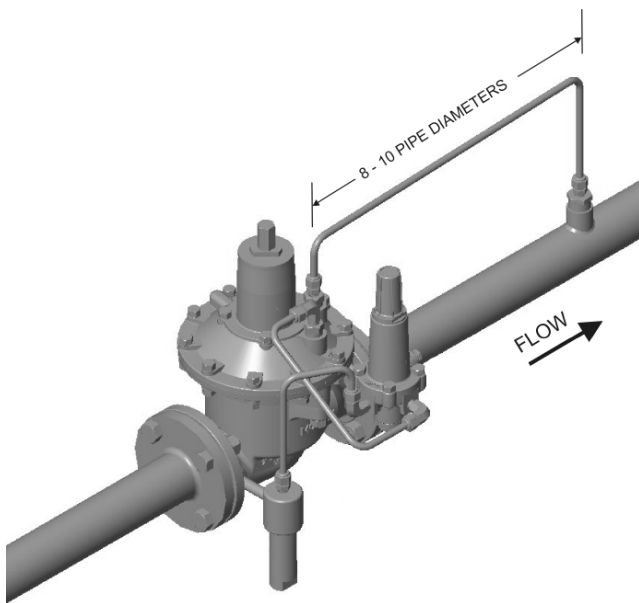

Loading Type Valve
(Pressure Reducing Valve)

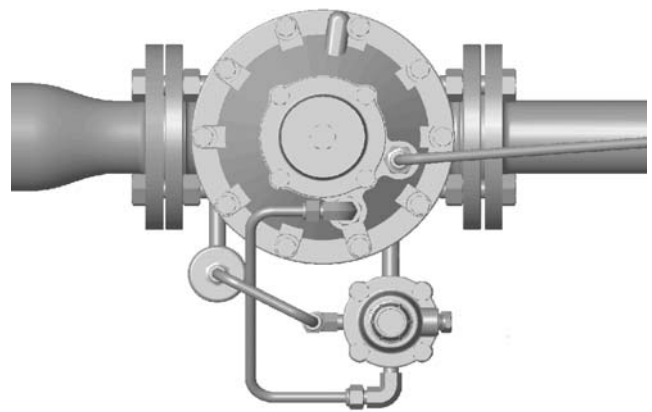

Typical Top View

Series 20 Pilot – Unloading and loading type valve installation

WARNING

Personal injury, equipment damage, or leakage due to explosion of accumulated gas or bursting of pressure containing parts may result if this valve/ regulator is overpressured or is installed where service conditions could exceed the limits given in the specification of this manual or on the nameplate, or where conditions exceed any ratings of the adjacent piping or piping connections. Verify the limitations of both valve and pilot to ensure neither device is overpressured. To avoid such injury or damage, provide pressure relieving or pressure limiting devices (as required by the U.S. code of Federal Regulations, by the National Fire Codes of the National Fire Protection Association, or by other applicable codes) to prevent service conditions from exceeding those limits. Additionally, physical damage to the regulator, pilot, or tubing can cause personal injury and/or property damage due to explosion of accumulated gas. To avoid injury and damage, install the valve in a safe location.

WARNING

Gas Regulators installed in confined or enclosed spaces should be provided with adequate ventilation to prevent the possibility of gas buildup or accumulation from leaks and venting. Leaks or vented gas may accumulate causing personal injury, death, or property damage. Pilot spring cases and the regulator enclosure should be vented to a safe area away from air intakes, or any hazardous location. The vent lines and stacks must be protected against condensation and plugging.

- 1. PERSONNEL:** Installation of the Series 20 Pilot the Flowgrid® Valve or any other manufacture's valve should be made by qualified personnel familiar with high-pressure piping and Pilot-operated Regulators.
- 2. PRIOR INSPECTION:** Inspect the Pilot for any damage that might have occurred in shipping.
- 3. CONTROL ACTION:** Inspect to make sure the Body Insert Assembly (Cartridge) is in the correct operational mode. Remove the Body Insert Assembly and measure the stem extension from the Body Insert. (Refer to the Maintenance section of this manual - Figure 20 & Figure 22, page 9.)

Pressure Reducing Mode (PRV): the stem extends 0.32 inches.

Back Pressure Mode (BPV): the stem extends 0.45 inches.

If incorrect, follow the Body Insert Assembly disassembly and assembly instructions in the Maintenance section of this manual.

- 4. ORIENTATION:** The Series 20 Pilot may be installed in any position - the best position being one that provides easiest access for pilot adjustment and valve maintenance.
- 5. PILOT MOUNTING:** Apply pipe dope to a short (1-1/2 inch long) 1/4 inch NPT Schedule 80 seamless pipe nipple and mount the pilot by connecting the loading connection on the pilot to the spring case or loading connection on the valve to be controlled. When mounting the Flowgrid® valve it is best if the pilot OUTLET connection is on the same side as the 1/4-inch NPT connections on the valve body. (Refer to the PIPING SCHEMATICS section of this manual).

NOTE: To avoid galling when stainless steel to stainless steel connections are made, use a lubricant (such as NEVER SEEZ by Bostik1). For best results Lightly lubricate the female threads. Mixing the lubricant with pipe dope is also acceptable. When tightening do not exceed more than 1/4 turn past the point the threads start to bind.

- 6. RESTRICTOR:** Mount a rotary scratch type restricting valve (such as the TYPE 24 RESTRICTOR) to the INLET port on the Flowgrid® Pilot. (Refer to PIPING SCHEMATICS section of this manual)
- 7. PILOT SUPPLY LINES:** Run a 3/8-inch tubing or 1/4-inch pipe supply line from the upstream piping or from the valve body connection on the inlet side of the valve to the pilot restrictor. The pilot supply connection should have a full and clean opening.
- 8. A FILTER** in the pilot supply line is recommended to remove dirt and other particulates that could affect the restrictor or variable orifice in the pilot. Refer to the **Type 30** Filter I/O/M manual for installation instructions.

NOTE: A shutoff valve is not required in the supply to the pilot, but if one is installed it should be a full opening type.

9. PILOT DISCHARGE UNLOADING TYPE VALVES

ONLY: Run 3/8 inch tubing or 1/4 inch pipe from the pilot OUTLET port to the downstream piping or to the connection provided on the outlet of the Flowgrid® valve as shown in the piping schematics. (Refer to page4).

STANDBY MONITOR-Note: To ensure full capacity of a Standby Monitor regulator station, it is important that the pilot discharge of the upstream regulator be connected downstream of the station if the minimum pressure drop (across the entire station) is below 60 psig.

10. PILOT GAS HEATERS (OPTIONAL): Pilot supply gas can be heated to prevent the formation of ice or hydrates in the pilot system. Pilot supply gas heaters should be connected after the pilot filter (if one is used).

11. CONTROL LINES: Control lines should be run from the SENSE Port of the Flowgrid® Pilot mounted on the valve to a point 8 to 10 pipe diameters away from the valve (refer to Piping Schematics).

Use Table 5 as a guide for the ideal tubing to use. Reduce as necessary to connect to the pilot.

Table 5

Pilot Regulator with:	Outlet Pressure		
	Inches to 2 psi	2 psi to 5 psi	5 psi & above
Static Sense Line (No Flow)*	1/2" Pipe minimum	1/2" Tubing	3/8" Tubing
Sense Line with Flow**	3/4" to 1" Pipe	1/2" Pipe	1/2" Tubing

*The Flowgrid® Series 20 Pilot has a static sense line.

** The Sense line of the FlowMax Actuator has flow.

NOTE: The control line connection should be away from areas of turbulence (such as valves, reducers, and elbows) and should have a full opening into the pipe, free from burrs, drill peels, and weld slag. Shutoff valves are not required in the control line(s), but if installed, they should be of the full opening type.

12. VENT VALVES AND GAUGE CONNECTIONS:

Troubleshooting recommendation. To aid in maintenance and troubleshooting, shut off and vent valves should be installed in tubing connections.

Maintenance

Pilot parts are subject to normal wear and must be inspected and replaced as necessary. The frequency of inspection and replacement of parts depends on severity of service conditions and/or the requirements of local, state, and federal regulations. Be certain that the name plates are updated to accurately indicate any field changes in equipment, materials, service conditions, or pressure settings.

WARNING

Before disassembly make sure the regulator and pilot have been isolated from the process by closing block valves on the inlet and outlet sides of the regulator. Safely release pressure and process fluid from the regulator body and pilot system. Failure to properly complete these steps may result in personal injury and property damage.

1. After depressurizing the pilot and main valve unscrew and remove Body Insert Assembly.
2. Remove the Stem O-ring from the pilot body using a suitable tool and being careful not to scratch the O-ring Groove.



Figure 12 - A paper clip easily pops the O-Ring out of the pilot body.

NOTE: A spare Body Insert Assembly may be installed and the regulator returned to service if time is a factor. Make sure the Stem O-Ring is still in place in the Pilot Body before installing the new Body Insert Assembly or, if removed, slip a new O-Ring over the Stem of the Body Insert Assembly prior to installing it in the Pilot Body.

Maintenance (cont'd)

Pilot Disassembly - All Series 20 pilots

3. Remove the Bottom Cap from the Body Insert and remove the internal parts. The Orifice Assembly can be easily pushed out of the Body Insert using a heavy paper clip or .045 diameter wire.

NOTE: Do not damage the O-Ring sealing surface of the Body Insert.

4. Inspect all parts for wear or damage. Replace as necessary.
5. **Pilot Diaphragm:** Release all spring tension by unscrewing Adjusting Screw. Remove Closing Cap, Spring Follower, and Main Spring. Remove Spring Housing Screws and remove Diaphragm Assembly. Disassemble Diaphragm Assembly and inspect Diaphragm. Replace if necessary.



Figure 13 - The orifice can be pushed out of the Body Insert (Cartridge) using a paper clip.

Pilot Assembly - Series 20 & 20S

(Refer to Page 10 for the Series 20H & 20 HS Assembly Instructions)

1. Diaphragm Assembly: Install the Pilot Diaphragm with convex side toward Diaphragm Plate and Main Spring (Refer to Figure 14). Tighten nut on the Diaphragm Retainer to approximately 5 to 6 ft-lbs torque.

NOTE: Overtightening will distort the Pilot Diaphragm.

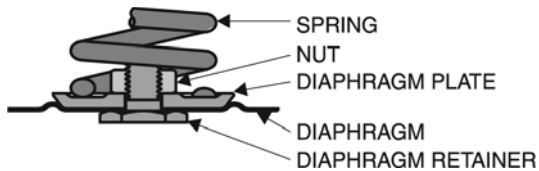

Figure 14 - Diaphragm Assembly for the Flowgrid® Series 20 & 20S Pilot.

2. Place Diaphragm Assembly in the pilot body with the diaphragm touching the grooved sealing surface of the pilot body. (Refer to Figure 15)



Figure 15 - Placing Diaphragm Assembly on Pilot Body.

Maintenance (cont'd)

Pilot Assembly - Series 20 & 20S

- Place Spring Housing on Pilot Body with vent connection in desired position. It is recommended that the vent connection face down when the pilot is mounted on the regulator so that condensation will drain away instead of accumulating and possibly freezing.



Figure 16 - Placing the Spring Housing on the Pilot Body.

- Install Spring Housing Cap Screws. Use cap screws supplied and tighten evenly to 10 ft-lbs torque.
- Install Spring and Spring Follower. Lubricate Spring Follower with a Petroleum Oil Grease such as Lubriplate NO. 105¹.



Figure 17 - Installing the Spring with lubricated Spring Follower.

- PILOTS WITH THE RED, CADMIUM, BLUE, AND PURPLE SPRINGS:** Install Closing Cap with Adjusting Screw and Sealing Nut and O-Ring.



Figure 18 - Installing the closing cap assembly for Pilot with the Red, Cadmium, Blue, and Purple Springs.

- PILOTS WITH BLACK AND GREEN SPRING:** Install Closing Cap with Adjusting Screw, Spacer, Sealing Nut, and O-Ring. The spacer prevents the Black and Green springs from being over compressed.



Figure 19 - Installing the closing cap assembly with spacer (to prevent spring over compression) for Pilots with the Black and Green Springs.

Maintenance (cont'd)

Body Insert (Cartridge) Assembly - All Pilots

Pressure Reducing (PRV) Mode

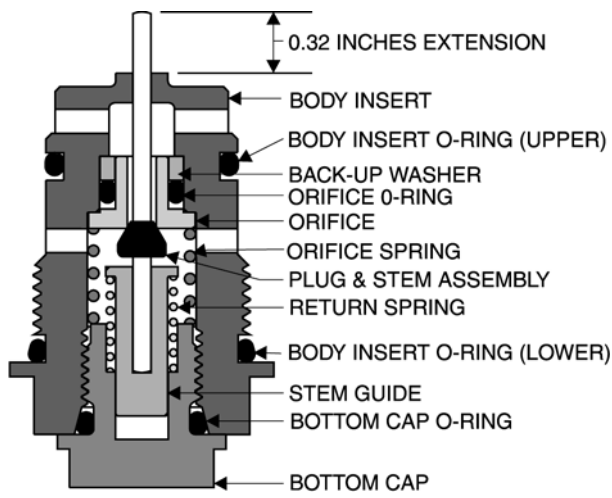

Figure 20

7A. Refer to Figure 20 & 21. Stack the following parts on the bottom cap in the order shown in the drawing:

- Return Spring
- Stem Guide
- Orifice Spring
- Plug and Stem
- Orifice
- Orifice O-Ring
- Back-up Washer



Figure 21 - Stack the Return Spring, Stem Guide, Orifice Spring, Plug and Stem, Orifice, Orifice O-Ring, and Back-up Washer on the Closing Cap.

Back Pressure or Relief (BPV) Mode

7B. Refer to Figure 22 & 23. Stack the following parts on the

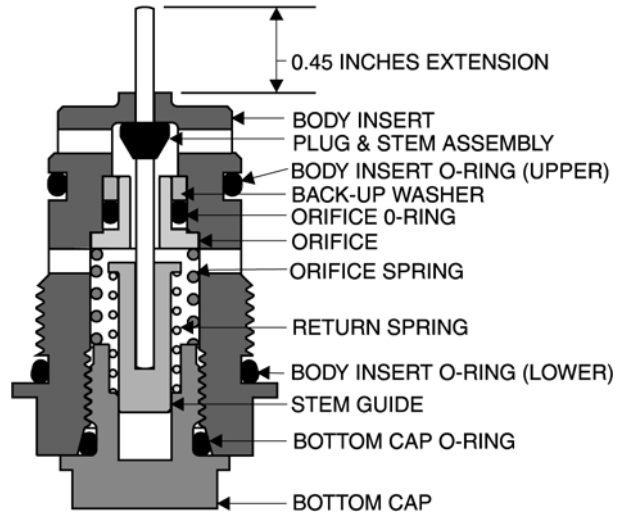

Figure 22

bottom cap in the order shown in the drawing:

- Return Spring
- Stem Guide
- Orifice Spring
- Orifice
- Orifice O-Ring
- Back-up Washer
- Plug and Stem

NOTE: The plug on the Stem will be ABOVE the Orifice Assembly for a Back Pressure or Relief Mode (Refer to Figure 22).

The plug will be BELOW the Orifice for the Pressure Reducing Mode (Refer to Figure 20).

The Orifice has a seating surface on both ends. The flange end of the Orifice must sit on the Orifice Spring.

Maintenances (cont'd)

Pilot Assembly (cont'd) - Series 20 & 20S



Figure 23 - In the back pressure mode the plug/stem assembly is inverted.

8. Lubricate both Body Insert O-Rings with Parker O-Lube1 (or equivalent Petroleum based Lubricant) and install on Body Insert (Cartridge).
9. Body Insert Assembly: Lift Bottom Cap complete with valve mechanism and insert into Body Insert. The Orifice Spring should snap the Orifice into place as the Bottom Cap is screwed into place. Check the assembly by pushing the Stem against a hard surface to make sure it moves freely and returns to the extended position.

Measure the stem extension.

Pressure Reducing mode: 0.32 inches

Back Pressure or Relief mode: 0.45 inches

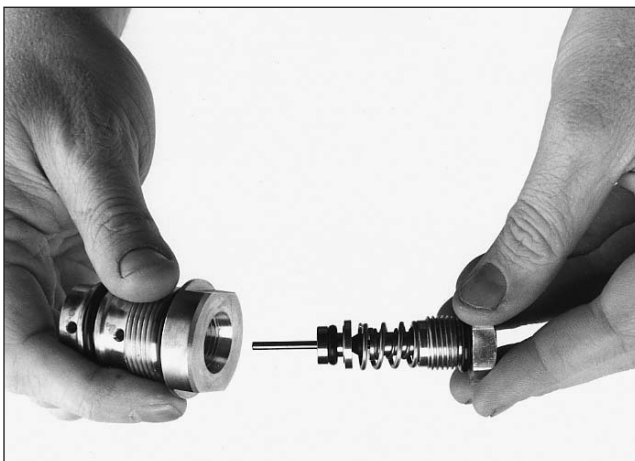

Figure 24 - Insert the assembly into the Body Insert - the orifice should "snap" into place.

10. Lubricate Stem O-Ring with Parker Super-O-Lube1 (or equivalent Silicon Lubricant) and slip over Stem.

11. Insert Body Insert into Pilot Body and screw into place snugly.

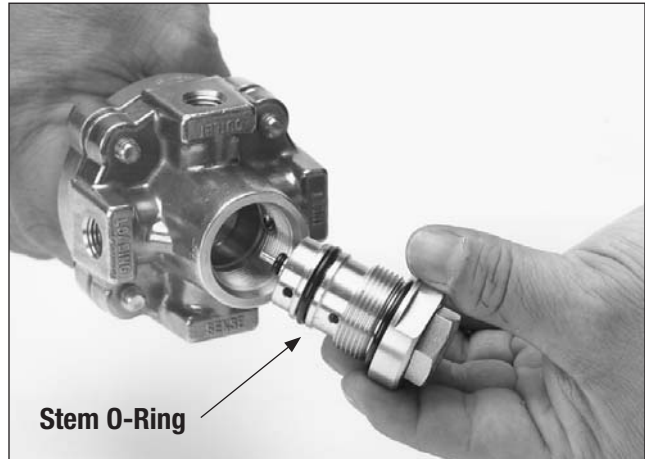

Figure 25 - Insert Body Insert (Cartridge) with lubricated Stem O-Ring into the Pilot Body.

NOTE: Over tightening an O-Ring Joint will not improve the seal. Screw in until metal parts make contact and snug slightly.

12. Pilot Assembly is now complete.

Pilot Assembly (cont'd) - Series 20H & 20HS

NOTE: The high pressure constructions (Series 20H & 20HS) differs for the Series 20 & 20S with the addition of a diaphragm spacer assembly that limits the effective area of the diaphragm and doubles the spring range of the black and green springs.

1. **Diaphragm Assembly:** Install the Pilot Diaphragm with convex side toward Diaphragm Plate and Main Spring (Refer to Figure 26). Tighten nut on the Diaphragm Retainer to approximately 5 to 6 ft-lbs torque.

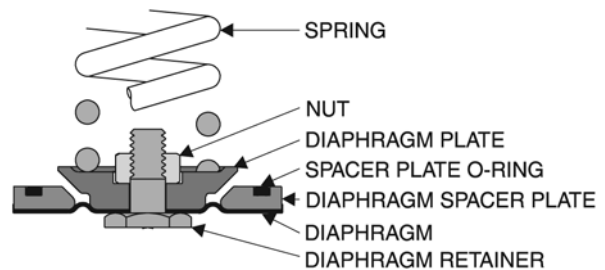

Figure 26- Insert Body Insert (Cartridge) with lubricated Stem O-Ring into the Pilot Body.

NOTE: Over tightening will distort the Pilot Diaphragm.

Maintenances (cont'd)

Pilot Assembly (cont'd) Series 20H & 20HS

- Place Diaphragm Assembly in the pilot body with the diaphragm touching the grooved sealing surface of the pilot body and the O-Ring facing up. (Refer to Figure 26 & Figure 27).



Figure 27 - Placing high pressure Diaphragm Assembly on Pilot Body.

- Place Spring Housing on Pilot Body with vent connection in desired position. The recommended position is with the vent connection facing down when the pilot is mounted on the regulator so that condensation will drain away instead of accumulating and possibly freezing. (Refer to Figure 16).
- Install Spring Housing Cap Screws. Use Cap Screws supplied and tighten evenly to 10 ft-lbs torque.

- Install Spring and Spring Follower.

NOTE: The Flowgrid® SERIES 20H & 20HS use only the Black and Green Springs.

- Follow assembly directions for Series 20 & 20S Pilot for steps 6B through 10. **Note the exception to Step 7 for the Series 20H & 20HS below.**
- The Series 20H and 20HS Pilots in back pressure mode require a delrin orifice and all stainless steel stem/plug in the Body Insert (Cartridge). Assemble the orifice assembly the same way you would the Back Pressure Body Insert (Cartridge) with the stainless steel orifice and stainless/nitrile stem/plug assembly. (Refer to Figure 22 & Figure 28).

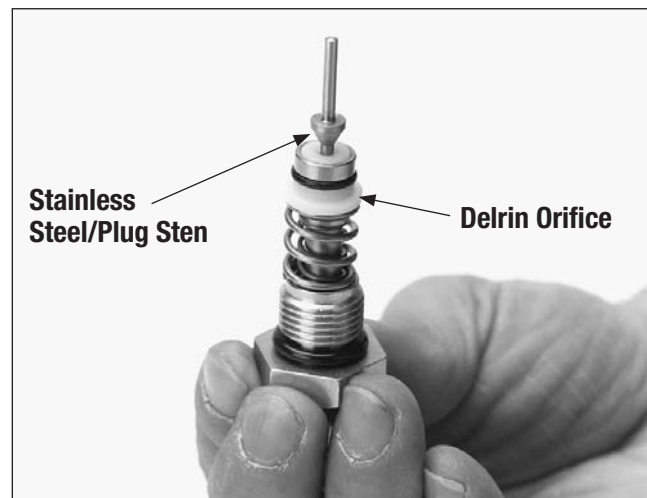

Figure 28 - The Series 20H & 20HS use a Delrin Orifice and Stainless Steel Plug/Stem assembly in the Back Pressure mode. The white Delrin material distinguishes itself from the standard stainless steel orifice.

PRODUCT SUPPORT

Local support is available through our manufactures representative and distributor network. Contact the factory or refer to our web site for your support representative contact information. Factory support is available from 8:00AM to 4:30 PM MST Monday through Friday. Limited after hours support is also available. Complete product specifications, parts lists, and flow calculation software is available on our web site.

www.dresser.com/mooney 801-487-2225 USA.

WARRANTY

LIMITED WARRANTY: Seller warrants title and that the goods manufactured by the Seller will be free from defects in materials and workmanship under normal use and service until the expiration of the earlier of twelve (12) months from the date of initial operation or eighteen (18) months from the date of shipment by Seller. Resale goods shall carry only the warranty extended by the original manufacturer to the original purchaser. If, within thirty (30) days after Buyer's discovery of any warranty defects, Buyer notifies Seller in writing, Seller shall, at its option, promptly repair or replace F.O.B. point of manufacture, that portion of the goods found by Seller to be defective. Goods repaired and parts replaced during the original warranty period shall be in warranty for the remainder of the original warranty period. This warranty is the only warranty made by Seller and can only be amended by a written instrument signed by an officer of Seller. Subject to this warranty and except as expressly provided **IN SALES LITERATURE, DRESSER MOONEY CONTROLS, DRESSER, INC. MAKES NO REPRESENTATION OR WARRANTY OF ANY KIND, EXPRESS OR IMPLIED, AS TO MERCHANTABILITY, FITNESS FOR PARTICULAR PURPOSE, OR ANY OTHER MATTER WITH RESPECT TO ANY OF THE PRODUCTS.**

While the information in this manual is presented in good faith and believed to be accurate, Dresser Pressure Regulation Group, Dresser, Inc. does not guarantee satisfactory results from reliance on such information. Dresser Pressure Regulation Group, Dresser Inc. reserves the right, without notice, to alter or improve the designs or specifications of the products described herein.

About Dresser® products

Dresser brand products are highly engineered, technically superior and are designed to help global customers meet and exceed requirements for mission critical energy applications.

About Dresser, Inc.

Dresser, Inc. is a leader in providing highly engineered infrastructure products for the global energy industry. The company has leading positions in a broad portfolio of products, including valves, actuators, meters, switches, regulators, piping products, natural gas-fueled engines, retail fuel dispensers and associated retail point-of-sale systems, and air and gas handling equipment. Leading brand names within the Dresser portfolio include Dresser Wayne® retail fueling systems, Waukesha® natural gas-fired engines, Masoneilan® control valves, Consolidated® pressure relief valves, and Roots® blowers. It has manufacturing and customer service facilities located strategically worldwide and a sales presence in more than 100 countries.

Mooney

Dresser, Inc.

2822 S. 1030 W.
Salt Lake City, Utah 84119
Phone: 801.487.2225 Fax: 801.487.2587
www.dresser.com/mooney



www.dresser.com