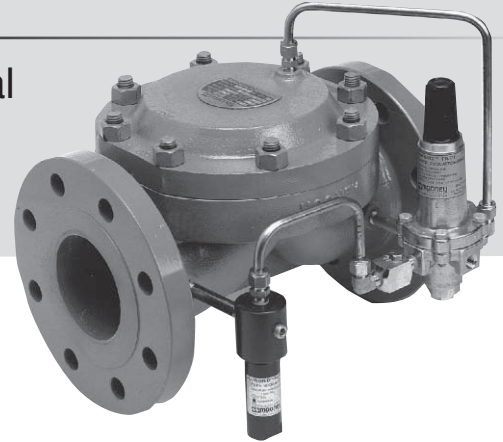


# Flowgrid® Regulator

## Installation/Operation/Maintenance Manual



### Table of Contents

Product Description.....	1	Piping Details.....	7-10
Valve Markings .....	3	Start-up and Operation.....	11
Nameplate Information .....	3	Maintenance .....	13-14
Principles of Operation .....	4-5	Troubleshooting.....	15
Hydrostatic Testing.....	5	Warranty.....	16
Installation .....	6-7		

### Scope

This manual provides installation, operation, and maintenance instructions for the Flowgrid® valve and regulator. Instructions for the Series 20 Pilot will be found in a separate manual.

### Product Description

The Flowgrid® valve is an easy to maintain valve designed to be used primarily with a self contained pilot system. The Flowgrid® valve has several unique features that add to its versatility such as:

- In line maintenance.
- Replaceable trim.
- Reversible trim parts.
- Dual flow elements for added capacity or redundancy.
- Non stretching fabric reinforced diaphragm for stability and fast response at all temperatures.

- Positive spring shutoff.
- Two-stage pressure drop to minimize noise and provide cavitation protection.

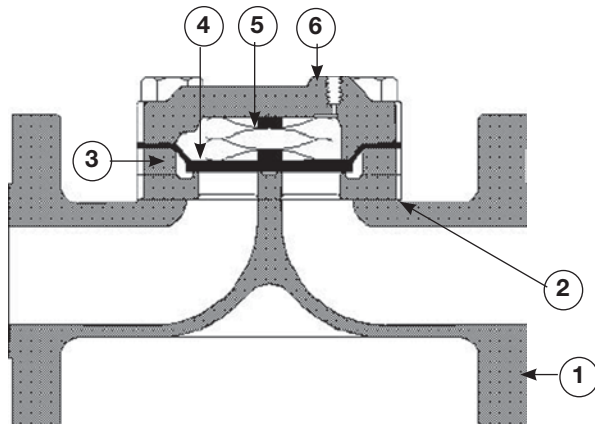
Refer to Figure 1 (Page 2).

All Flowgrid® valves have six main parts (excluding bolting and O-rings); the body, throttle plate, spacer, diaphragm, main spring, and spring case. Although parts vary in size and design, all valves share the same principle of operation.

The body (1) is available with single or dual ports. The dual port design (figure 3) can provide redundant control if equipped with dual pilots or be used with a single pilot for maximum capacity.

**Table 1**

Materials of Construction	
Body & Spring Case	ASTM A 216 WCB Carbon Steel
Spacer	ASTM A 216 WCB Carbon Steel
Throttle Plate	17-4PH Stainless Steel
Diaphragm	Nitrile/Nylon Optional (Viton/Nitrile)
O-Ring & Seals	Nitrile Optional (Viton)
Bolting	ASTM 193 GR B-7 or Equal
Spring	301 Stainless Steel



**Figure 1**

The **throttle plate (2)** supports the diaphragm and provides a machined surface that the diaphragm seals against for bubble tight shutoff. Restricted capacity plates of 35%, 50%, and 75% are available.

The **spacer (3)** creates a space between the throttle plate and the diaphragm which forms a flow path inside the valve.

The **fabric-reinforced diaphragm (4)** is the main working part of the Flowgrid® valve. The diaphragm functions as both an actuator and the valve throttling element.

It is designed to provide stability, rangeability, and fast response without stretching. It will not “take a set” and is thick for durability and wear resistance.

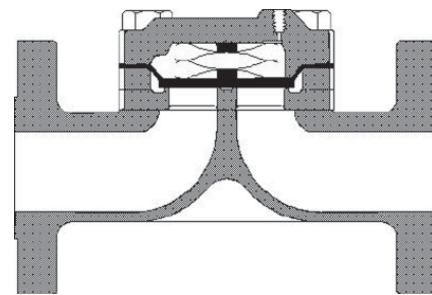
The **main spring (5)** provides high frequency response, proportional action for stability and a consistent minimum differential regardless of temperature. It also provides a positive closing force, which is important in monitor regulation application.

The **spring case (6)** is shaped to retain the main spring. It provides a low volume cavity where loading pressure from the pilot system is placed on top of the diaphragm to control flow through the regulator.

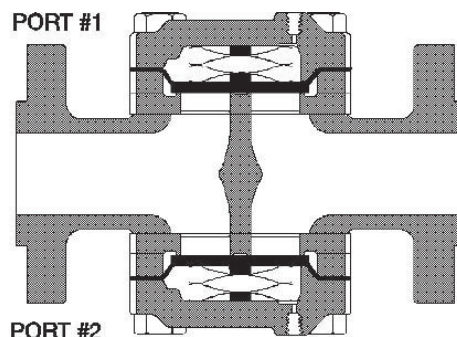
**Table 2**

Specifications	
<b>Sizes</b>	1 inch thru 12 inch
<b>Body Style</b>	Single Port and Dual Port
<b>End Connections</b>	Screwed, Socket Weld Flanged, Flangeless & Butt weld
<b>Temperature*</b>	-20°F to 150°F (-29°C to 66°F)
<b>Maximum Operating Differential</b>	800 psi
<b>Maximum Emergency Differential</b>	1000 psi (unless limited by body rating)
<b>Minimum Differential</b>	Refer to individual product specification sheets
<b>Cracking Differential</b>	Refer to individual product specification sheets
<b>Maximum Inlet Pressure</b>	1480 psig (limited by flange or pilot rating)
<b>Outlet Pressure Range</b>	Limited by pilot
<b>Flow Direction</b>	Bi-Directional*
<b>Body Taps</b>	1/4" - 18 NPT

\*Reverse flow by changing pilot connections and reversing spring case.

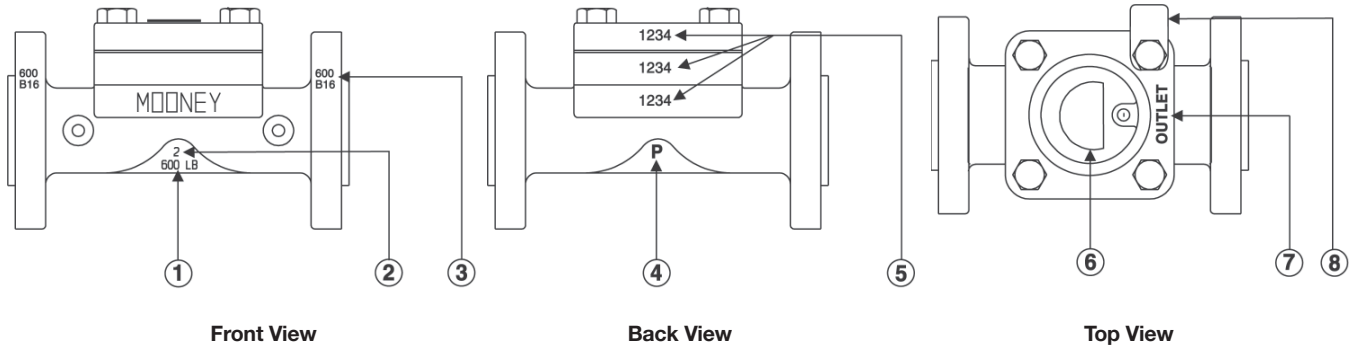


**Figure 2**



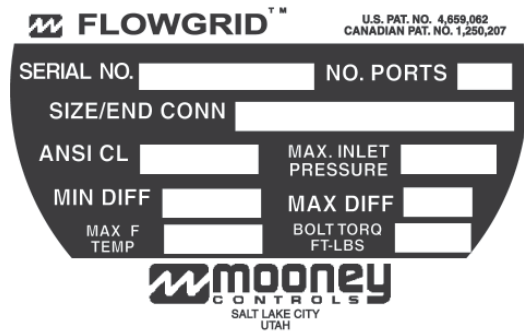
**Figure 3**

## Valve Markings



1. American National Standards Institute (ANSI) pressure class rating of the valve.
2. Line size of body.
3. ANSI pressure class rating of the flange.
4. Indication that the valve has been hydrostatically tested according to code requirements.
5. The serial number is stamped on the spring case, spacer\*, and Body.
6. The Nameplate location.
7. The flow direction is marked on the spring case ("INLET" or "OUTLET"). Proper alignment assures that the diaphragm guide on the Spring Case is aligned toward outlet side of the valve.
8. The % Capacity tag indicates the capacity of the throttle plate (100%, 75%, 50%, & 35%) in the valve.  
NOTE: On all 1" valves and 2" standard valves the throttle plate itself is stamped.

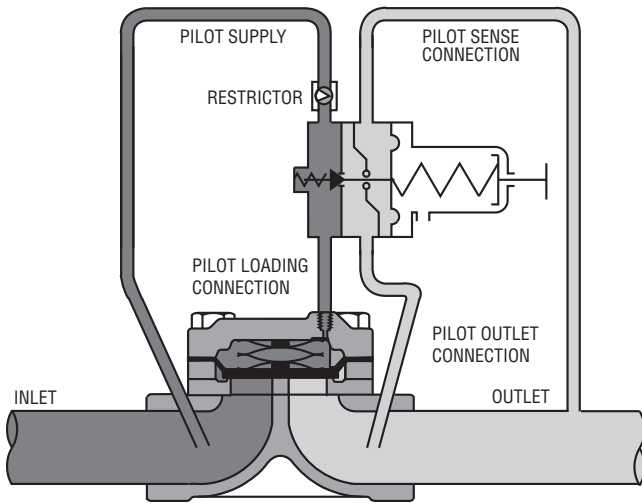
## Nameplate Information



Item	Definition
<b>Flowgrid®</b>	Registered name of valve
<b>BLANK</b>	CE Marking
<b>SN</b>	Serial number assigned to valve
<b>FG</b>	Flowgrid® Model description
<b>SIZE/END CONN</b>	Line size of body and type of end connection
<b>ANSI CL</b>	American National Standards Institute pressure class
<b>MAX INLET PRESSURE</b>	Maximum inlet pressure (psig)
<b>YR</b>	Year manufactured
<b>DIFF/MIN/MAX</b>	Minimum differential required to fully open valve Maximum allowable operating pressure differential (psig)
<b>MAX F TEMPERATURE</b>	Maximum Operating Temperature in degrees Fahrenheit
<b>BOLT TORQ FT-LBS</b>	Recommended bolt torque for spring case in foot pounds

## Principal of Operation

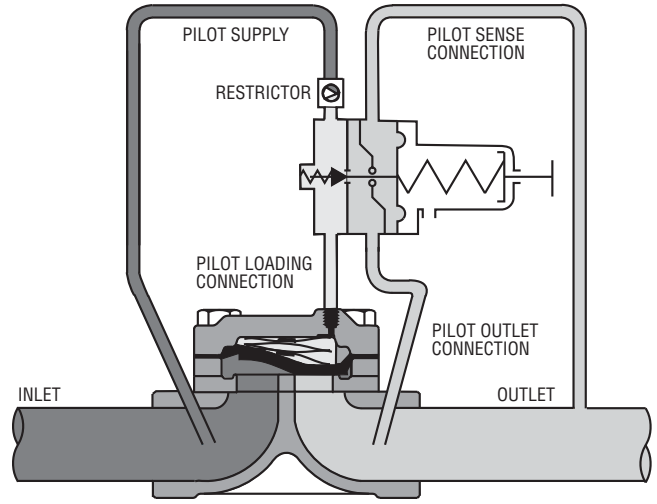
### Pressure Reducing Application (PRV)



**Figure 4. Pressure Reducing Configuration Fully Closed**

At no flow, when the outlet pressure is greater than the set point of the pilot regulator, the pilot is closed and full inlet pressure loads the spring case through the pilot loading connection. In this condition the diaphragm is closed tightly against the throttle plate. The pressure differential across the outlet half of the diaphragm adds to the spring force in closing the Flowgrid® valve (Refer to Figure 4).

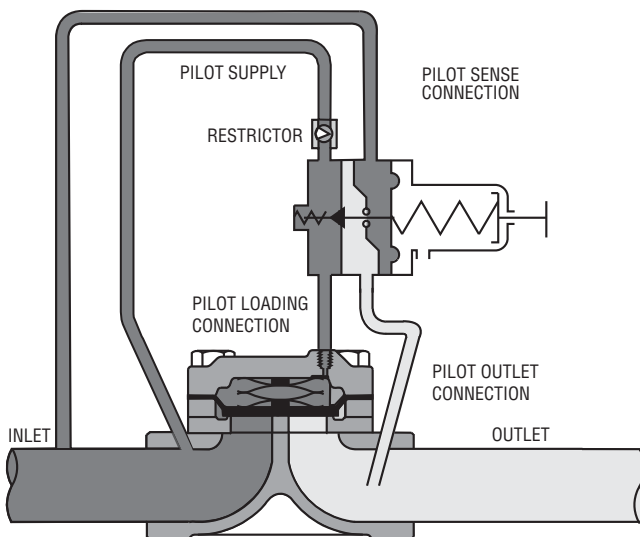
As demand for flow occurs in the downstream system the outlet pressure drops, causing the pilot regulator to open and start bleeding pressure out of the spring case faster than it can enter through the restrictor. Reducing the pressure above the diaphragm allows the inlet pressure to progressively lift the diaphragm off the throttle plate, opening the valve and satisfying the demand for flow in the downstream system. (Refer to Figure 5).



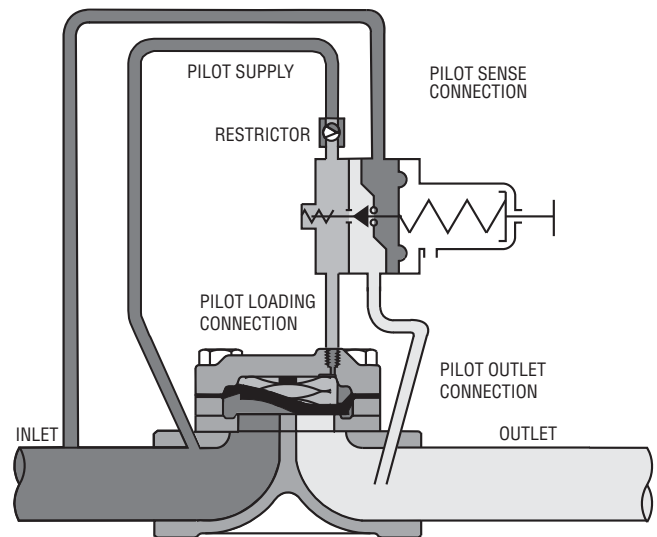
**Figure 5. Pressure Reducing Configuration Partially Open**

When demand for flow ceases or is reduced, the downstream pressure increases causing the pilot regulator to close. Inlet pressure continues to pass through the restrictor until the control pressure equals the inlet pressure. The spring force, plus the pressure differential across the outlet half of the diaphragm closes the diaphragm against the throttle plate, shutting off the flow (Refer to Figure 4).

Adjustment of the restrictor affects the response rate, stability, and sensitivity of the regulator. Smaller restrictor openings result in higher gain (sensitivity) and slower closing speeds. Larger openings result in lower gain (greater proportional band), greater stability and faster closing speeds.



**Fig 6. Back Pressure Configuration Fully Closed**



**Fig 7. Back Pressure Configuration Partially Open**

A back pressure regulator or relief valve controls upstream pressure instead of downstream pressure. The control action in the pilot is the reverse of a pilot for a pressure reducing valve (increasing pressure in the sense chamber opens the pilot valve). At no flow, when the inlet pressure is less than the set point of the pilot regulator, the pilot is closed and full inlet pressure loads the spring case through the pilot loading connection. In this condition, the diaphragm is closed tightly against the throttle plate. The pressure differential across the outlet half of the diaphragm adds to the spring force in closing the Flowgrid® valve (Refer to figure 6).

As inlet pressure increases above the set point of the pilot regulator, it will open and start bleeding pressure out of the spring case faster than it can enter through the restrictor. Reducing the pressure above the diaphragm allows inlet

pressure to progressively lift the throttling element off the throttle plate opening the valve and satisfying the demand for flow in the upstream system (Refer to Figure 7).

When upstream pressure decreases, causing the pilot regulator to close, pilot supply pressure continues to pass through the restrictor until the control pressure equals the inlet pressure. The spring force, plus the pressure differential across the outlet half of the throttling element closes the diaphragm against the throttle plate, shutting off the flow (Refer to Figure 6).

Adjustment of the restrictor affects the response rate, stability, and sensitivity of the regulator. Smaller restrictor openings result in higher gain (sensitivity) and slower closing speeds. Larger openings result in lower gain (greater proportional band), greater stability and faster closing speeds.

## Hydrostatic Testing

All Flowgrid® valves are hydrostatically tested at the factory prior to shipment according to ISA-S75.19-1989 and MSS-SP-61 standards. If it is necessary to retest the valve, follow one of the procedures listed below to prevent damage to the diaphragm.

### OPTION 1

1. Disconnect and remove all control line(s) and the pilot from the Flowgrid® Valve.
2. Loosen main spring case nuts in a crisscross pattern. The main spring will lift the spring case as the nuts are removed.
3. Remove main spring and diaphragm from valve.

### FOR ALL 1", 2", 4", AND 6" (AND 10"-V6) FLOWGRID® VALVES

4. Replace diaphragm with a used diaphragm that has the thick padded area cut out leaving the outer sealing surface (see below).



← This area removed

### FOR 3" AND 4" x 3" FLOWGRID® VALVES

4. Remove diaphragm but leave diaphragm O-ring in place. Make sure O-ring is properly seated.
5. Reassemble spring case on Flowgrid® valve.
6. Tighten main bolts in increments using a crisscross pattern. Torque bolting as indicated on valve nameplate (or refer to Table 5 Page 14).
7. Plug spring case loading port, pilot inlet and outlet taps on Flowgrid® valve.
8. Refer to Table 3 for the maximum hydrostatic test pressure of each Flowgrid® valve.
9. After hydrostatic test is completed follow the Disassembly, Cleaning, and Assembly procedures in the MAINTENANCE section of this manual.

### OPTION 2

1. Disconnect and remove all control line(s) and pilot from the Flowgrid® valve.
2. Pipe regulator with the inlet, outlet, and loading connections all common so that pressure is equalized in the entire valve during the hydrostatic test. See Figure 8.
3. Refer to Table 3 for Maximum hydrostatic test pressure of each Flowgrid® valve.
4. After hydrostatic test is completed follow the Disassembly, Cleaning, and Assembly procedures in the MAINTENANCE section of this manual.

Table 3

### Maximum Hydrostatic Test Pressures

End Connection	Maximum Hydrostatic Test Pressure (psi)
Screwed & Socket Weld	2225
150# Flange & Flangeless	450
300# Flange & Flangeless	1125
600# Flange & Flangeless	2225
Flowgrid 250***	375

\*\* The Flowgrid® 250 is a ductile iron construction.

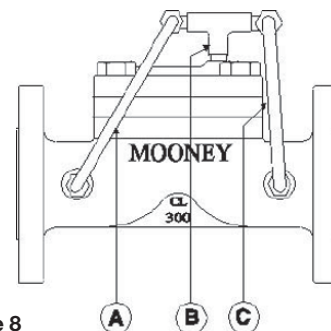


Figure 8

- A. Inlet connection on valve body joined to "Tee".
- B. "Tee" connected to loading connection on spring case.
- C. Outlet of "Tee" connected to outlet connection on valve

## Installation

- PERSONNEL:** Installation of the Flowgrid® valve/regulator should be made by qualified personnel familiar with high pressure piping and pilot operated regulators.

### WARNING

Personal injury, equipment damage, or leakage due to explosion of accumulated gas or bursting of pressure containing parts may result if this valve/regulator is overpressured or is installed where service conditions could exceed the limits given in the specification of this manual or on the nameplate, or where conditions exceed any ratings of the adjacent piping or piping connections. Verify the limitations of both valve and pilot to ensure neither device is overpressured. To avoid such injury or damage, provide pressure relieving or pressure limiting devices (as required by Title 49, Part 192, of the U.S. code of Federal Regulations, by the National Fire Codes of the National Fire Protection Association, or applicable codes) to prevent service conditions from exceeding those limits. Additionally, physical damage to the valve/regulator could break the pilot off the main valve, causing personal injury and/or property damage due to explosion of accumulated gas. To avoid such injury and damage, install the regulator in a safe location.

- PRIOR INSPECTION:** Inspect the main valve, pilot, and tubing for any damage that might have occurred in shipping. Make sure the body, pilot lines, and inlet piping are clear and free from foreign material.
- ORIENTATION:** The Flowgrid® valve may be installed in any position - the best position being one that provides easiest access for pilot adjustment and valve maintenance.
- SCREWED END VALVES:** Apply pipe compound to the male threads starting one or two threads back from the end prior to assembling the joint.
- FLANGED END VALVES:** Use suitable line gaskets and good bolting practices with flanged bodies. A crisscross pattern of incrementally tightening the line bolts is recommended.
- WELD END BODIES:** Remove the Spring Case and all trim parts including diaphragm and O-rings before welding a butt weld and/or a socket weld end Flowgrid® valve. Electric arc welding is recommended to minimize heat build-up on the body assembly. Reassemble valve (refer to the MAINTENANCE section of this manual for Disassembly and Assembly procedures) and pressurize with air to check for leaks prior to putting the valve in service.

### WARNING

Gas Regulators installed in confined or enclosed spaces should be provided with adequate ventilation to prevent the possibility of gas buildup or accumulation from leaks and venting. Leaks or vented gas may accumulate causing personal injury, death, or property damage. Pilot spring cases and the regulator enclosure should be vented to a safe area away from air intakes, or any hazardous location. The vent lines and stacks must be protected against condensation and clogging.

- PILOT SUPPLY LINES:** Run a 3/8-inch or 1/2-inch pilot supply line from the valve body connection on the inlet side of the Flowgrid® valve to the pilot supply Filter or directly to the pilot Restrictor.

**NOTE:** A shutoff valve is not required in the supply to the pilot, but if one is installed it should be a full opening ball valve type.

- A TYPE 30 FILTER** in the pilot supply line is recommended to clean dirt and other particulates that could affect the restrictor or variable orifice in the pilot. Use a 1/4" nipple to mount the filter to the body tap on the Flowgrid® valve.
- FILTER OUTLET:** Run 3/8 inch tubing or 1/4- inch pipe from the filter OUTLET port to the INLET side of the restrictor in the pilot system of the regulator. The TYPE 30/30A/30S FILTER has two OUTLET ports for ease of tubing. Block the other port with the plug provided or mount a gage to monitor inlet pressure if desired.

**NOTE:** To avoid galling when stainless steel to stainless steel connections are made use a lubricant (such as NEVER SEEZ by Bostik). For best results Lightly lubricate the female threads. Mixing the lubricant with pipe dope is also acceptable. Do not exceed more than 1/4 turn past the point the threads start to bind.

- PILOT GAS HEATERS (OPTIONAL):** Pilot supply gas can be heated to prevent the formation of ice or hydrates in the pilot system. Pilot supply gas heaters should be connected after the pilot filter (if one is used). Do not directly heat to entire Flowgrid® valve to prevent freezing; internal rubber components can be heated beyond their max temperature rating causing potential damage.
- CONTROL LINES:** Control lines should be run from the pilot mounted on the Flowgrid® valve to a point 8 to 10 pipe diameters away from the valve (Refer to Piping Schematics). Use Table 4 as a guide for the ideal tubing to use. Reduce as necessary to connect to the pilot.

	Outlet Pressure		
<b>Pilot Regulator with:</b>	Inches W.C. to 2 psi	2 psi to 5 psi	5 psi & above
<b>Static Sense Line (No Flow)*</b>	1/2" Pipe minimum	1/2" Tubing	3/8" Tubing
<b>Sense Line with Flow*</b>	3/4" to 1" Pipe	1/2" Pipe	1/2" Tubing

\*The Flowgrid® Series 20 Pilot has a static sense line.

**NOTE: The control line connection should be away from areas of turbulence (such as valves, reducers, and elbows) and should have a full opening into the pipe free from burrs, drill peels, and weld slag. Shutoff valves are not required in the control line(s), but if installed, they should be of the full opening type.**

**12. PILOT discharge:** Run 3/8 inch tubing from the pilot OUTLET port to the downstream piping or to the connection provided on the outlet of the Flowgrid® valve as shown in the piping schematics. (Refer to pages 7-11).

**STANDBY MONITOR-NOTE:** To ensure full capacity of a Standby Monitor regulator station, it is important that the pilot discharge of the upstream regulator be connected downstream of the station if the minimum pressure drop (across the entire station) is below 60 psig. (Refer to page 9 and page 12).

**13. VENT VALVES AND GAUGE CONNECTIONS:** Vent valves and gauge connections are recommended in the inlet and outlet piping to the Flowgrid® valve. A gauge connection may be installed on the loading pressure

connection to the Spring Case of the Flowgrid® valve. These would be a great convenience during start up, maintenance, and operation.

**14. INTERSTAGE PIPING (WORKING MONITOR):**

On Working Monitor regulator stations the recommended length of the interstage piping is 6 pipe diameters or 36-inches, whichever is greater. It is also recommended that the interstage piping be swaged up 1 pipe diameter over the nominal port size of the valve. (Refer to page 10).

**FOR EXAMPLE:**

1. If a station has two 3" Single Port Flowgrid® valves, the interstage piping should be at least 36-inches in length and swaging up to a 4-inch pipe.
2. If the station has two 2" x 1" Flowgrid® valves, (this valve has two inch flanges with a one inch port) the interstage piping should be at least 36-inches in length and a 2 inch pipe diameter.

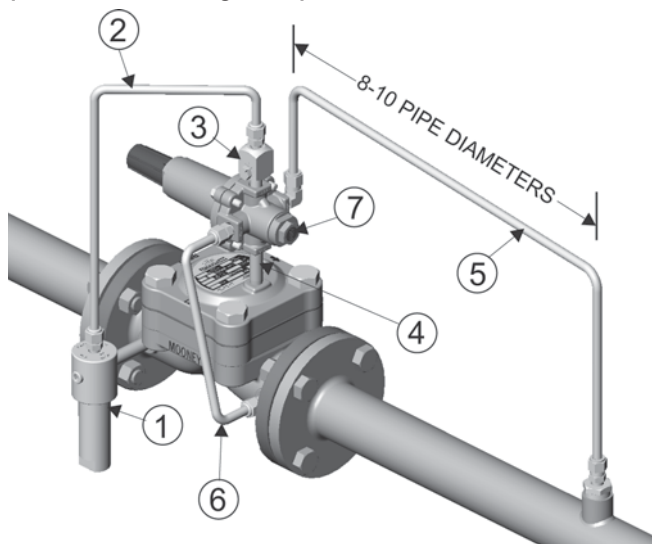
**Piping Schematics**

1. Single Port Regulator (PRV).
2. Single Port Regulator (BPV).
3. Dual Port Regulator/Single Pilot/(PRV).
4. Dual Port Regulator/Single Pilot/(BPV).
5. Dual Port Regulator/Dual Pilot/(PRV).
6. Dual Port Regulator/Dual Pilot/(BPV).

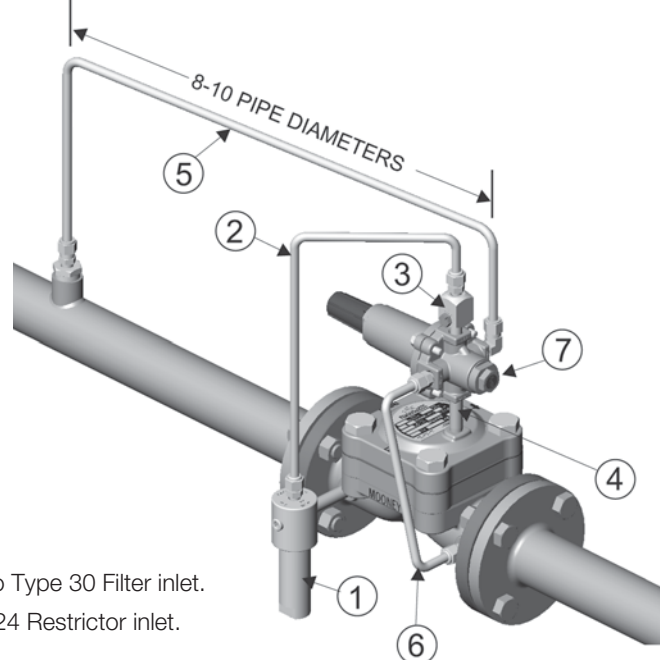
7. Standby Monitor with differential greater than 60 psig.
8. Standby Monitor with differential less than 60 psig.
9. Working Monitor.

All drawings show installations with the Series 20 Flowgrid® pilot equipped with Type 24 restricting valve & Type 30 Filter. Consult factory for installation schematics of other manufacturer's pilot on the Flowgrid® valve.

**Single Regulator/ Single Pilot (Pressure Reducing Valve)**



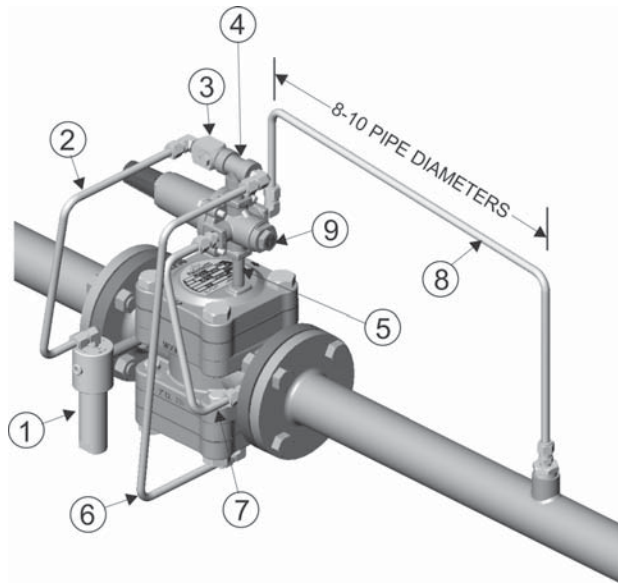
**Single Regulator/ Single Pilot (Back Pressure Valve)**



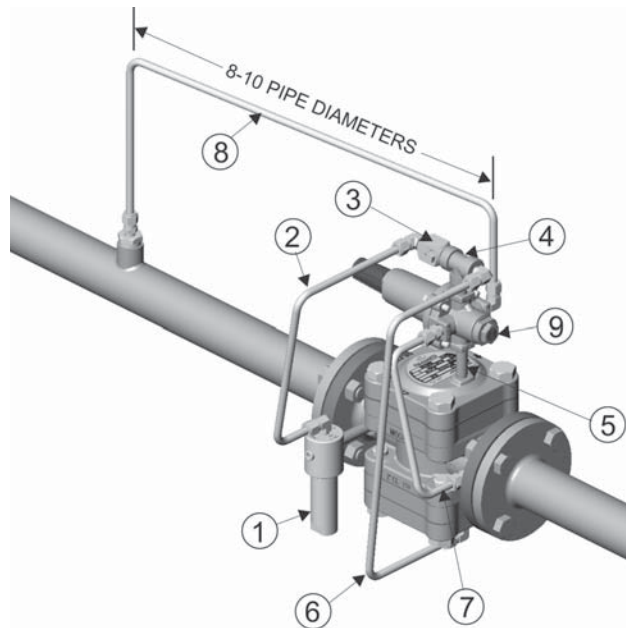
1. Filter supply connected from inlet connection on valve body to Type 30 Filter inlet.
2. Pilot supply from outlet connection on Type 30 Filter to Type 24 Restrictor inlet.
3. Type 24 Restrictor mounted to Inlet port of Series 20 Pilot.
4. Loading Port of Series 20 Pilot connected to Loading connection on Spring Case of Flowgrid® valve.
5. Sense line connecting Sense port on Series 20 Pilot to upstream (BPV) or downstream (PRV) piping.
6. Outlet port of Series 20 Pilot connected to Outlet connection of Flowgrid® valve.
7. Pilot cartridge in PRV mode (pressure reducing) BPV (back pressure / relief) mode.

## Piping Schematics (cont.)

### Dual Port/ Single Pilot (Pressure Reducing Valve)

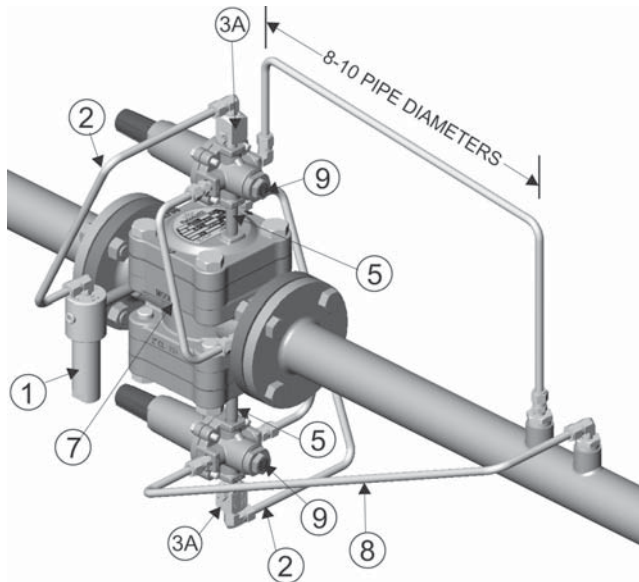


### Dual Port/Single Pilot (Back Pressure Valve)

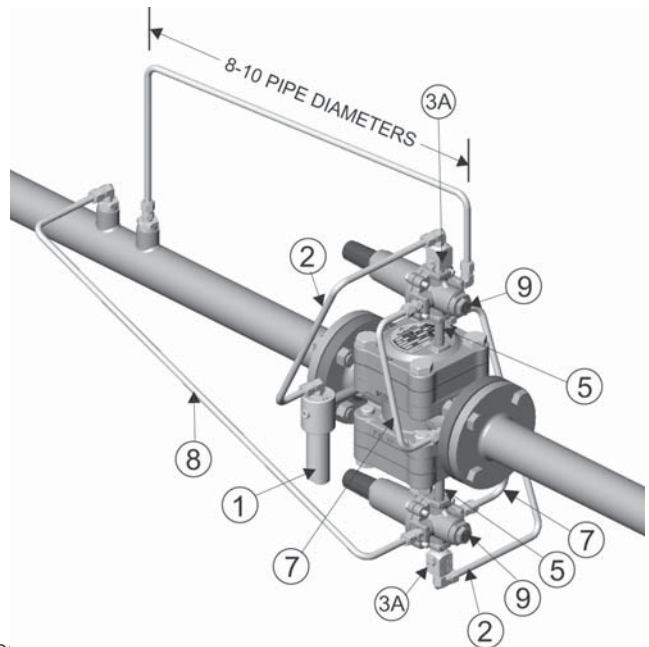


### Dual Port/Dual Pilot (Pressure Reducing Valve)

**NOTE:** The dual port regulator offers redundant control with two separate control loops. Ports #1 & #2 are piped identically.



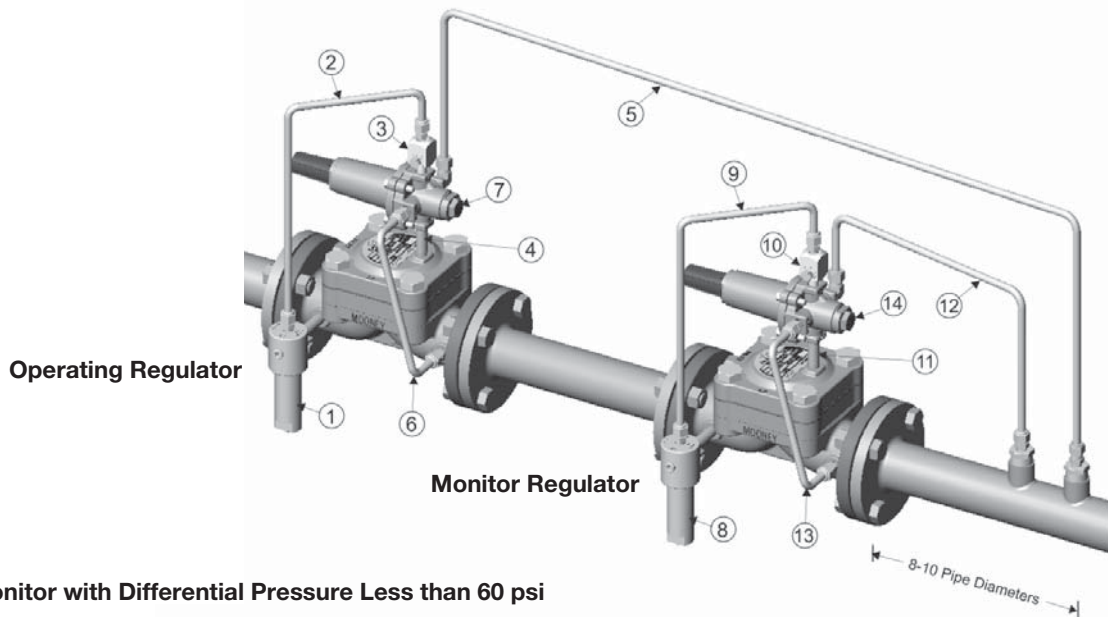
### Dual Port/Dual Pilot (Back Pressure Valve)



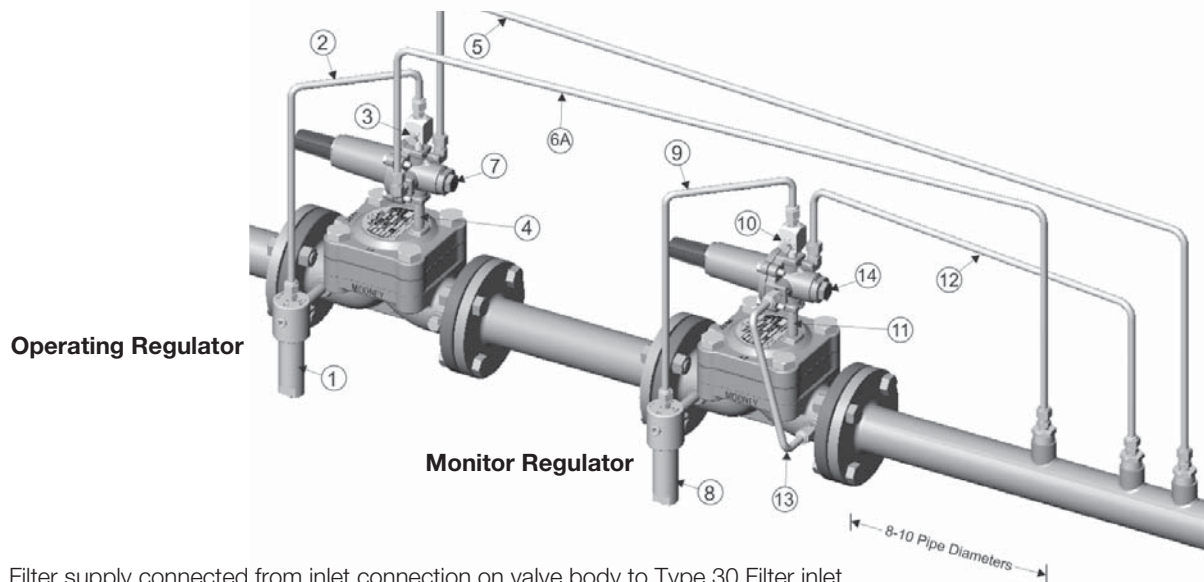
1. Filter supply connected from inlet connection on valve body to Type 30 Filter inlet.
2. Pilot supply from outlet connection on Type 30 Filter to Type 24 Restrictor inlet.
3. Type 24 Restrictor mounted to "Tee" connection.
- 3A. Type 24 Restrictor mounted to Inlet port of Series 20 Pilot.
4. Tee mounted to Inlet Port of Series 20 Pilot.
5. Loading Port of Series 20 Pilot connected to Loading connection on Spring Case (Port #1) of Flowgrid® Valve.
6. From "Tee" to Spring Case (Port #2) of Flowgrid® valve.
7. Outlet port of Series 20 Pilot connected to Outlet connection of Flowgrid® valve.
8. Sense line connecting Sense port on Series 20 Pilot to downstream (PRV) or upstream (BPV) piping
9. Pilot cartridge in PRV mode (pressure reducing) BPV (back pressure/relief) mode.

## Piping Schematics (cont.)

### Standby Monitor with Differential Pressure Greater than 60 psi



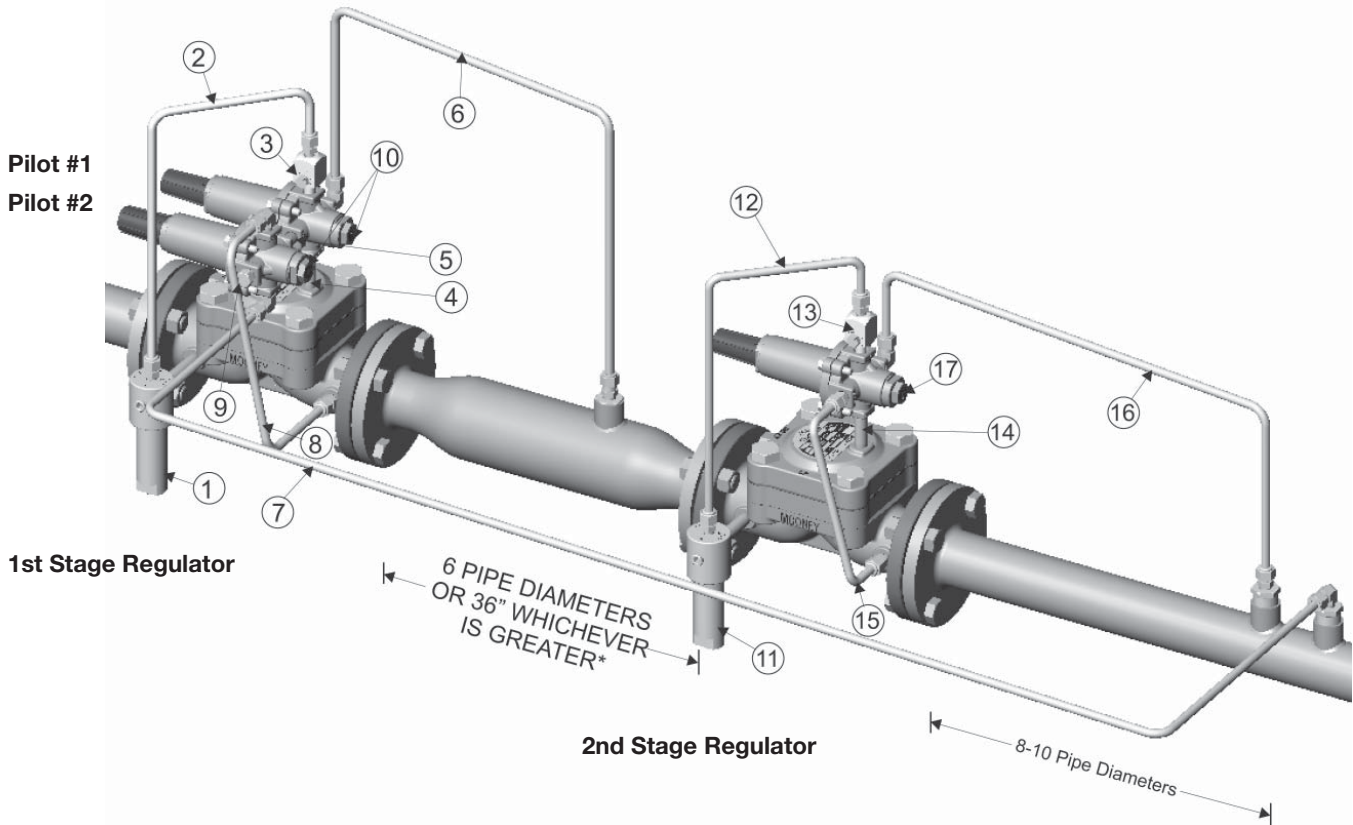
### Standby Monitor with Differential Pressure Less than 60 psi



1. Filter supply connected from inlet connection on valve body to Type 30 Filter inlet.
2. Pilot supply from outlet connection on Type 30 Filter to Type 24 Restrictor inlet.
3. Type 24 Restrictor mounted to Inlet port of Series 20 Pilot.
4. Loading Port of Series 20 Pilot connected to Loading connection on Spring Case of Flowgrid® valve.
5. Sense line connecting Sense port on Series 20 Pilot to downstream piping.
6. Outlet port of Series 20 Pilot connected to Outlet connection of Flowgrid® valve.
- 6A. Outlet port of Series 20 Pilot connected to downstream piping.
7. Pilot cartridge in PRV mode.
8. Pilot supply from inlet connection on valve body to Type 30 Filter inlet.
9. Pilot supply from outlet connection on Type 30 Filter to Type 24 Restrictor inlet.
10. Type 24 Restrictor mounted to Inlet port of Series 20 Pilot.
11. Loading Port of Series 20 Pilot connected to Loading connection on Spring Case of Flowgrid® valve.
12. Sense line connecting Sense port on Series 20 Pilot to downstream piping.
13. Outlet port of Series 20 Pilot connected to Outlet connection of Flowgrid® valve.
14. Pilot cartridge in PRV mode.

## Piping Schematics (cont.)

**Working Monitor** (Refer to schematic on page 14)



### 1st Stage Regulator

1. Filter supply connected from inlet connection on valve body to Type 30 Filter inlet.
2. Pilot supply from outlet connection on Type 30 Filter to Type 24 Restrictor inlet.
3. Type 24 Restrictor mounted to Inlet port of Series 20 Pilot (#1).
4. Loading Port of Series 20 Pilot (#1) connected to Loading connection on Spring Case of the Flowgrid® valve.
5. Outlet port of Series 20 Pilot (#1) connected to Inlet port of the monitor Series 20 Pilot (#2).
6. Sense line connecting sense port on Series 20 Pilot to interstage piping.
7. Sense line connecting sense port on the monitor Series 20 Pilot (#2) to downstream piping.
8. Outlet port of Series 20 Pilot (#2) connected to Outlet connection of Flowgrid® valve.
9. Loading port on the monitor Series 20 pilot (#2) is plugged.
10. Pilot cartridges in PRV mode.

### 2nd Stage Regulator

11. Filter supply connected from inlet connection on valve body to Type 30 Filter inlet.
12. Pilot supply from outlet connection on Type 30 Filter to Type 24 Restrictor inlet.
11. Pilot supply tubing from inlet connection on valve body to Type 24 Restrictor inlet.
13. Type 24 Restrictor mounted to Inlet port of Series 20 Pilot (#3).
14. Loading Port of Series 20 Pilot (#3) connected to Loading connection on Spring Case of the Flowgrid® valve.
15. Outlet port of Series 20 Pilot (#3) connected to Outlet connection of Flowgrid® valve.
16. Sense line connecting Sense port on Series 20 Pilot (#3) to downstream piping.
17. Pilot (#3) cartridge in PRV mode.

**NOTE: In a working Monitor system with less than 25 psig differential across the second stage regulator the pilot supply (11) may be connected to the piping upstream of the first stage regulator. This will improve the shutoff of the second stage regulator.**

## Start Up and Operation

The following procedures are suggested for start up of the Flowgrid® valve/regulator. Start up of the Flowgrid® valve/regulator should be made by qualified personnel familiar with high pressure systems and pilot operated regulators.

### WARNING

**The instruction manual for the PILOT(S) being used should be consulted to ensure that the installation and start up instructions for the pilot are followed. Some pilots can be damaged if not installed and put into operation correctly.**

#### Pressure Reducing Regulator

1. Adjust the pilot restrictor to an intermediate opening (a “4” setting on the Mooney Type 24 Restrictor).
2. Back off on the pilot adjusting screw to fully relieve all the spring compression.
3. If installed, open hand valve(s) in the control line(s), and the pilot supply line.
4. Crack open downstream block valve or open vent in piping downstream of the Flowgrid® valve.
5. Slowly open the upstream block valve to pressurize the Flowgrid® valve and pilot system. The Flowgrid® valve should lock up (shut off) with zero pressure downstream.
6. Use vent in the downstream piping or slowly open the outlet block valves.
7. Slowly increase the pilot spring setting until some flow is achieved through vent or into downstream system. Adjust the pilot restrictor for stability and performance as follows:
  - a. If the system is stable, adjust the pilot restrictor to a more closed position (towards MIN setting). Change the flow rate or increase the pilot setting to check the operation of the system during an upset.
  - b. If the system is stable, repeat step (a) until the system is unstable (oscillating).
  - c. Now readjust the restriction to a more open position (towards MAX setting) where the system is stable.
  - d. Vary the flow rate over as wide a range as possible to make sure the system will be stable under all flow conditions.

**NOTE: Adjustment of the restrictor affects the response rate, stability, and sensitivity of the regulator. CLOSING the pilot restrictor (moving adjustment towards MIN setting) will result in higher gain (narrow the proportional band), more sensitivity, and slower closing speeds. OPENING the pilot restrictor (moving the adjustment towards MAX setting) will result in less gain (widen the proportional band), less sensitivity, and faster closing speeds.**

8. Slowly increase the pilot spring setting until the desired downstream pressure is achieved.
9. Slowly close the downstream block valve or vent to check the Flowgrid® valve for lockup (shut off).
10. Slowly open the downstream block valve.

#### Back Pressure Regulator or Relief Valve

1. Adjust the pilot restrictor to an intermediate opening (a “4” setting on the Mooney Type 24 Restrictor).
2. Increase pilot spring compression to maximum or some margin above desired setting.
3. If installed, open hand valves(s) in the control line(s), and the pilot supply line.
4. Check that the Flowgrid® valve is vented to atmosphere or the downstream system is ready to accept flow.
5. Open the downstream block valve or open vent in piping downstream of the Flowgrid® valve.
6. Slowly crack open the upstream block valve to pressurize the Flowgrid® valve and pilot system.

The Flowgrid® valve should lock up (shut off) with zero pressure downstream.
7. Slowly decrease the pilot spring setting until some flow is achieved. The flow may only be through the pilot system.
8. Adjust the pilot restrictor for stability and performance as follows:
  - a. If the system is stable, adjust the pilot restrictor to a more closed position (towards MIN setting). Change the flow rate or increase the pilot setting to check the operation of the system during an upset.
  - b. If the system is stable, repeat step (a) until the system is unstable (oscillating).
  - c. Now readjust the restriction to a more open position (towards MAX setting) where the system is stable.
  - d. Vary the flow rate over as wide a range as possible to make sure the system will be stable under all flow conditions.

**NOTE: Adjustment of the restrictor affects the response rate, stability, and sensitivity of the regulator.**

CLOSING the pilot restrictor (moving adjustment towards MIN setting) will result in higher gain (narrow the proportional band), more sensitivity, and slower closing speeds. OPENING the pilot restrictor (moving the adjustment towards MAX setting) will result in less gain (widen the proportional band), less sensitivity, and faster closing speeds.

9. Slowly adjust the pilot spring setting until the desired upstream pressure (relief setting) is achieved.

## Standby Monitor

**NOTE:** This procedure is based on the 1st Regulator being the operating regulator and the 2nd regulator being the monitor regulator.

1. Set operating pilot (#1) spring at the MAXIMUM setting.
2. Set monitor pilot (#2) spring to the MINIMUM (zero) setting.
3. Slowly open inlet block valve. Purge, if necessary, any pressure in the station. Full inlet pressure should be present at the Monitor Regulator and the Monitor Regulator should be closed.
4. Open vent or downstream block valve.
5. Increase the pilot spring setting of the Monitor Regulator until the desired monitor override setting is reached. Lock in pilot setting.
6. With some flow going through the station, start to lower the operating pilot setting of the Operating Regulator until the desired outlet pressure is achieved.

**NOTE:** When the set point of the Operating Regulator becomes less than the set point of the Monitor regulator, the interstage pressure will drop from approximately full inlet pressure to 5-10 PSI above the outlet pressure at low flow rates.

## Checking Standby Monitor Operation

1. With flow going through the station, slowly increase the setting of the Operating Regulator. When the pressure reaches the setpoint of the Monitor Regulator, the monitor should take control and the interstage pressure should increase to almost full inlet pressure.
2. Reduce the setting of the Operating Regulator back to the required outlet pressure. The interstage pressure should drop to 5-10 PSI above the outlet pressure as the Operating Regulator takes control.

**NOTE:** When the differential across the entire station (P1-P2) is less than 60 PSIG then pipe alternate outlet as shown above. This applies to the Series 20 Pilot only; consult with Mooney for applicability to other manufacturer's pilots.

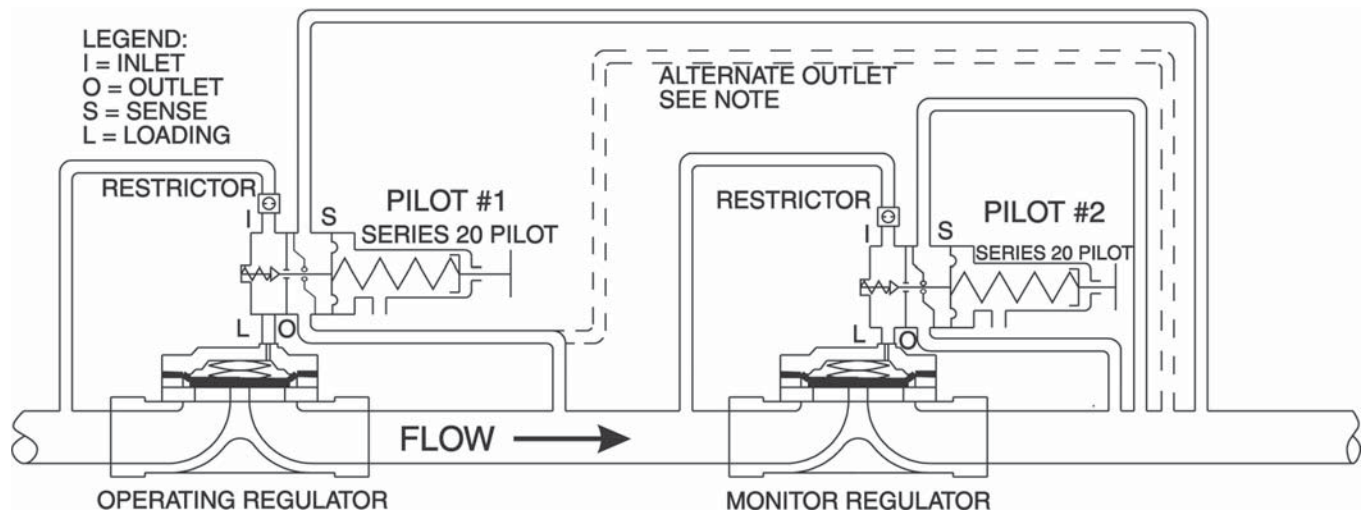


Figure 9. Standby Monitor Schematic

## Standby Monitor

### Working Monitor

1. Purge station and open outlet valve or vent to allow flow through the station.
2. Set pilot (#3) to a high setting above desired setpoint.
3. Set pilot (#1) to a high setting above desired setpoint.
4. Set the Monitor pilot (#2) at a zero setting.
5. Set restrictor on Pilot (#1) at an intermediate opening (a "4" setting on the Mooney Type 24 Restrictor).
6. Slowly open the inlet block valve to station. The 1st Stage Regulator should remain closed as a result of the Monitor Pilot (#2) being set to zero.
7. Increase the setting of the Monitor Pilot (#2) to the desired pressure setting. If the valve is unstable, increase the restrictor opening until it becomes stable
8. Lower the setpoint of the 2nd stage regulator (Pilot #3) to the desired outlet pressure setting. Tune the restrictor on Pilot (#3) at this time. The 1st stage regulator should open or begin to control the interstage pressure at the setpoint of Pilot (#1).
9. Adjust the setpoint of Pilot (#1) to achieve the desired Interstage pressure. Tune the restrictor on Pilot (#1) at this time.
10. Raise the setpoint of Pilot (#3) to verify the setpoint of the Monitor Pilot (#2). Adjust if necessary. Check for system stability and adjust the restrictor on Pilot (#1) if required.
11. Return setpoint of Pilot (#3) to maintain the desired outlet pressure..

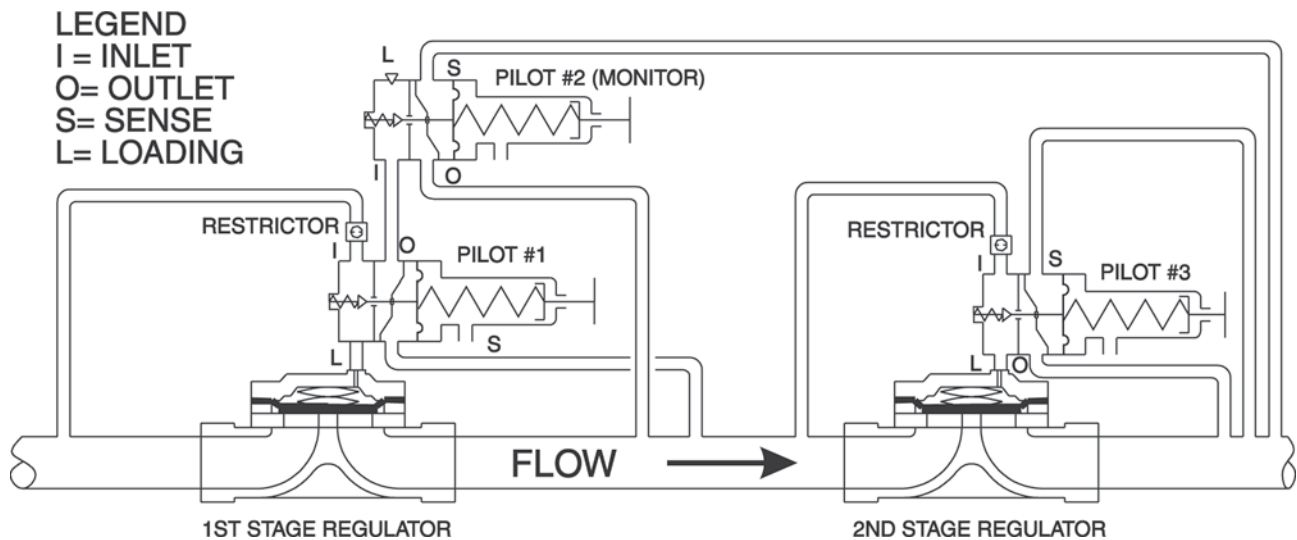


Figure 10. Working Monitor Schematic

**NOTE: In a working Monitor system with less than 25 psig differential across the second stage regulator the pilot supply may be connected to the piping upstream of the first stage regulator. This will improve the shutoff of the second stage regulator.**

## Maintenance

Regulator parts are subject to normal wear and must be inspected and replaced as necessary. The frequency of inspection and replacement of parts depends on severity of service conditions or the requirements of local, state, and federal regulations. Be certain that the name plates are updated to accurately indicate any field changes in equipment, materials, service conditions, or pressure settings.

Before disassembly make sure the regulator has been isolated from the process by closing block valves on the inlet and outlet sides of the regulator. Safely release pressure and process fluid from body and pilot system. Failure to complete these steps can result in personal injury and property damage.

## Maintenance (cont'd)

### Assembly

1. Disconnect control lines(s) and pilot supply line from pilot system.
2. Loosen main spring case nuts in a crisscross pattern. The main spring will lift the spring case as the nuts are removed.
3. Remove spring, diaphragm/throttling element, spacer, throttle plate and O-rings in that order.
4. Inspect all parts for wear and damage. Replace as necessary.

**NOTE: The periphery of the downstream (outlet) portion of the throttling plate is the primary shutoff surface and should be inspected most closely for wear and damage. Nicks and/or wear on the support ribs will usually not affect shutoff.**



The outside “rib” on the downstream side of the throttle plate is where shutoff takes place in the Flowgrid® Valve.

**NOTE: Nitrile O-rings can swell after disassembly of a regulator that has been in service (due to gas permeating the nitrile rubber). This does not necessarily mean they must be replaced. Set O-ring aside for several hours and it will gradually return to normal size. Placing the O-ring(s) on ice will speed the process considerably. Before placing the O-ring back into service inspect for defects.**

### Cleaning

1. DO NOT clean O-ring grooves with sharp metal tools. The bottom of the groove must have a smooth finish to prevent leakage. The mating surface of adjacent parts must also be smooth to prevent leakage.

## Assembly

**NOTE: Do not lubricate diaphragm sealing surface.**

1. Reassemble parts on the body per the assembly drawing in the parts supplement for the particular valve size.

**NOTE: Both the throttle plate and the diaphragm can be turned 180 degrees (not turned upside down) to renew the shutoff capability if the inlet side is in better condition than the outlet.**

2. Tighten main bolts in increments using a crisscross pattern. Torque bolting as indicated on valve nameplate (or refer to Table 4).

## Bolting Torque Values

### Clean Dry Bolts- Non-Lubricated

Table 5

Valve Size	Min. Torque Ft/Lbs
Flowgrid 250***	20
1" (ALL)**	25
2' x 1" (ALL)**	25
2" (ALL)**	60
3" (ALL)**	125
4" x 3" (ALL)**	125
4" (ALL)**	125
6" CL 150 & CL 300 Flanged	125
6" CL 600 Flanged	200
10" CL 150 & CL 300 Flanged	125
10" CL 600 Flanged	200
12" CL 150 & CL 300 Flanged	125
12" CL 600 Flanged	200
All Flowgrid Pilots	10

\*\*\* Refer to WARNING below.

### WARNING

Lubricating and/or overtightening the bolting can damage the Diaphragm in the 1" and 2" sizes of the Flowgrid® valve.

### WARNING

**DO NOT** replace the studs or nuts with any bolt or stud and nut combination that does NOT have an SAE Grade 7 or ASTM Grade B7 rating.

3. Reconnect the pilot system. Follow Start up procedures when returning to operation.

# Troubleshooting

## First Steps

- Verify** the regulator specifications fit the application conditions.  
Min/max inlet pressure, control pressure range & min/max operating differentials should be checked to make sure the valve and pilot are designed to operate in the present conditions.
- Verify** the regulator is piped correctly.  
Even though the regulator may have operated in the past, check that current piping connections match recommendations on pages 7-10.
- Verify** the regulator is sized correctly.  
Regulators operating below 10% or above 80% of their maximum capacity given current application conditions tend to have more problems. Consider reduced capacity trim or a larger regulator in these cases.

## Common Problems

### Regulator does not shut off.

- Refer to the failure mode chart to diagnose potential causes.
- Clean or replace valve and pilot components as necessary.

### Erratic Control.

- Check for damage, debris in the restrictor and control pilot. Replace, clean and lubricate components as necessary. Consider pilot supply filtration (Type 30 Filter).
- Check for the potential of hydrate formation or freezing liquids in the pilot system. If liquids are present consider gas conditioning before the pilot and/or valve, heating the supply gas to the regulator, or heating the pilot supply gas (pilot gas heater).
- Check the sense line location and assure it is away from turbulent locations. Moving the sense line to a new location often solves control problems.
- Check to make sure needle valves are not used on any pilot system connections. Full opening type valves are recommended.
- Check for pilot vent port blockage.

## Instability & Speed of response issues.

- Change restrictor setting. Refer to page 11.
- Check the sense line location and assure it is away from turbulent locations. Moving the sense line to a new location often solves control problems.
- Check to make sure needle valves are not used on any pilot system connections. Full opening type valves are recommended.
- Check for pilot vent port blockage.

### The regulator will not regulate to set point or “droops-off”.

- Check for proper sizing. The regulator may be running out of capacity during peak demand periods.
- Adjust the restrictor to a higher gain (smaller) setting. Refer to page 11.

### The regulator fails open or fails closed.

- Refer to the table below to diagnose failure modes.

Problem	Failure Mode	
	Fail Open	Fail Closed
Damage to the flexible element	X	X
Damage to the flexible element on the upstream side (less likely)		X
Damage to the flexible element on the downstream side (more likely)	X	
Debris between the flexible element and the seat	X	
Blockage of pilot supply pressure	X	
Blockage* of the restrictor	X	
Blockage* of the pilot supply line	X	
Loss of the sense line (PRV pilot)	X	
Loss of the sense line (Relief Pilot)		X
Blockage* of pilot discharge		X
Pilot diaphragm rupture if (PRV pilot)	X	
Pilot diaphragm rupture if (BPV relief pilot)		X
Blockage* of pilot orifice		X

\* Blockage can be caused by debris, hydrates, freezing or damage to the component involved.

## Product Support

Local support is available through our manufactures representative and distributor network. Contact the factory or refer to our web site for your support representative contact information. Factory support is available from 8:00AM to 4:30 PM MST Monday through Friday at 801-487-2225 USA. Limited after hours support is also available. Complete product specifications, parts lists, and flow calculation software is available on our web site: [www.dresser.com/mooney](http://www.dresser.com/mooney)

## Warranty

**LIMITED WARRANTY:** Seller warrants title and that the goods manufactured by the Seller will be free from defects in materials and workmanship under normal use and service until the expiration of the earlier of twelve (12) months from the date of initial operation or eighteen (18) months from the date of shipment by Seller. Resale goods shall carry only the warranty extended by the original manufacturer to the original purchaser. If, within thirty (30) days after Buyer's discovery of any warranty defects, Buyer notifies Seller in writing, Seller shall, at its option, promptly repair or replace F.O.B. point of manufacture, that portion of the goods found by Seller to be defective. Goods repaired and parts replaced during the original warranty period shall be in warranty for the remainder of the original warranty period. This warranty is the only warranty made by Seller and can only be amended by a written instrument signed by an officer of Seller. Subject to this warranty and except as expressly provided **IN SALES LITERATURE, DRESSER MOONEY REGULATORS, DRESSER, INC. MAKES NO REPRESENTATION OR WARRANTY OF ANY KIND, EXPRESS OR IMPLIED, AS TO MERCHANTABILITY, FITNESS FOR PARTICULAR PURPOSE, OR ANY OTHER MATTER WITH RESPECT TO ANY OF THE PRODUCTS.**

While the information in this manual is presented in good faith and believed to be accurate, Dresser Mooney Regulators, Dresser, Inc. does not guarantee satisfactory results from reliance on such information. Dresser Mooney Regulators, Dresser Inc. reserves the right, without notice, to alter or improve the designs or specifications of the products described herein.



**Dresser, Inc.**  
2822 S. 1030 W.  
Salt Lake City, Utah 84119  
Phone: 801.487.2225 Fax: 801.487.2587  
[www.dresser.com/mooney](http://www.dresser.com/mooney)



**Boundless Energy™**