

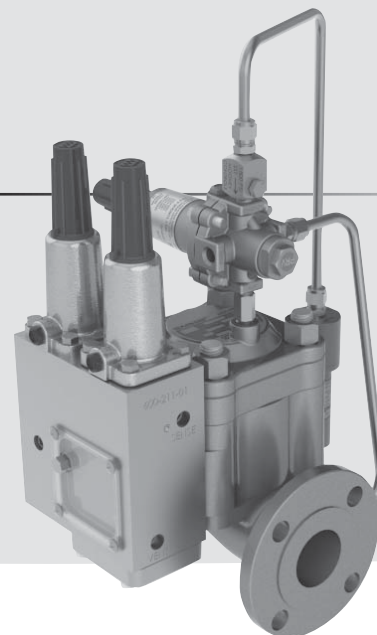

## 2" Flowgrid® 250 Regulator and Shutoff Valve

NPT CL 300 CL 150 RF, CL 300 RF

The 2" Mooney Flowgrid Slam Shut 250 is a combination of a regulator and a slam shut. In addition to pressure regulation, this pneumatically actuated device provides automatic downstream pressure protection. By separating the pneumatic controller and mechanical latching mechanism, shut off occurs only when designated set points are reached. The patent pending design prevents disruptive and costly "accidental shutoffs". Positive shutoff is achieved instantly through the snap acting mechanism, and reset can be completed with common tools.



Flowgrid® Regulator with Integral Shutoff Valve, Series 50D Dual Function Controller.

### Specifications

Size	2"
Body Style	Flowgrid 250 with Slamshut
End Connections	2" NPT CL 300, 2" 2" CL 150 RF Flange, 2" CL 300
Temperature	Working -20°F to 150°F (-29°C to 65°C)
Minimum Differential	Refer to Graph on pg 2
Cracking Differential	Refer to Graph on pg 2
Maximum Inlet Pressure	250 psig (17 bar)
Outlet Pressure Range	Limited by SSV controller and Series 20 Pilot
Flow Direction	Uni-Directional
Taps	Four 1/4" - 18 NPT (one inlet, one center port*, one loading and one downstream)

\*Center port - between flapper valve and regulator

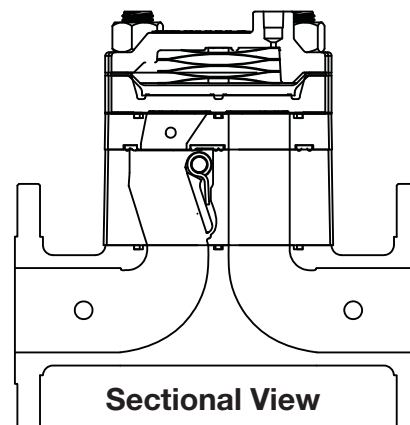

Sectional View

### Materials of Construction

Body	Ductile Iron ASTM A 395
Spring Case	ASTM A 356-T6 Hard Anodized Aluminum
Throttle Plate	ASTM A 356-T6 Hard Anodized Aluminum
Seal Retainer and Flapper Body	17 - 4PH Stainless Steel or A515 Carbon Steel with ENC Coating
Diaphragm	Nitrile/Nylon*
O-Ring and Seals	Nitrile
Studs and Nuts	ASTM A 193 GR B-7 ASTM A 194 GR 2H or Equal
Springs	301 Stainless Steel ASTM A 313-03 17-17 SS
Bushings	Acetal
Restricting Plates	Zinc Plated Carbon Steel

### Stock Numbers

2" Flowgrid 250 & Shutoff Valve	Stock Number	Weight
NPT CL 300	SG-82	55 lbs
150# Flange	SG-83	65 lbs
300# Flange	SG-84	65 lbs

## Dimensions

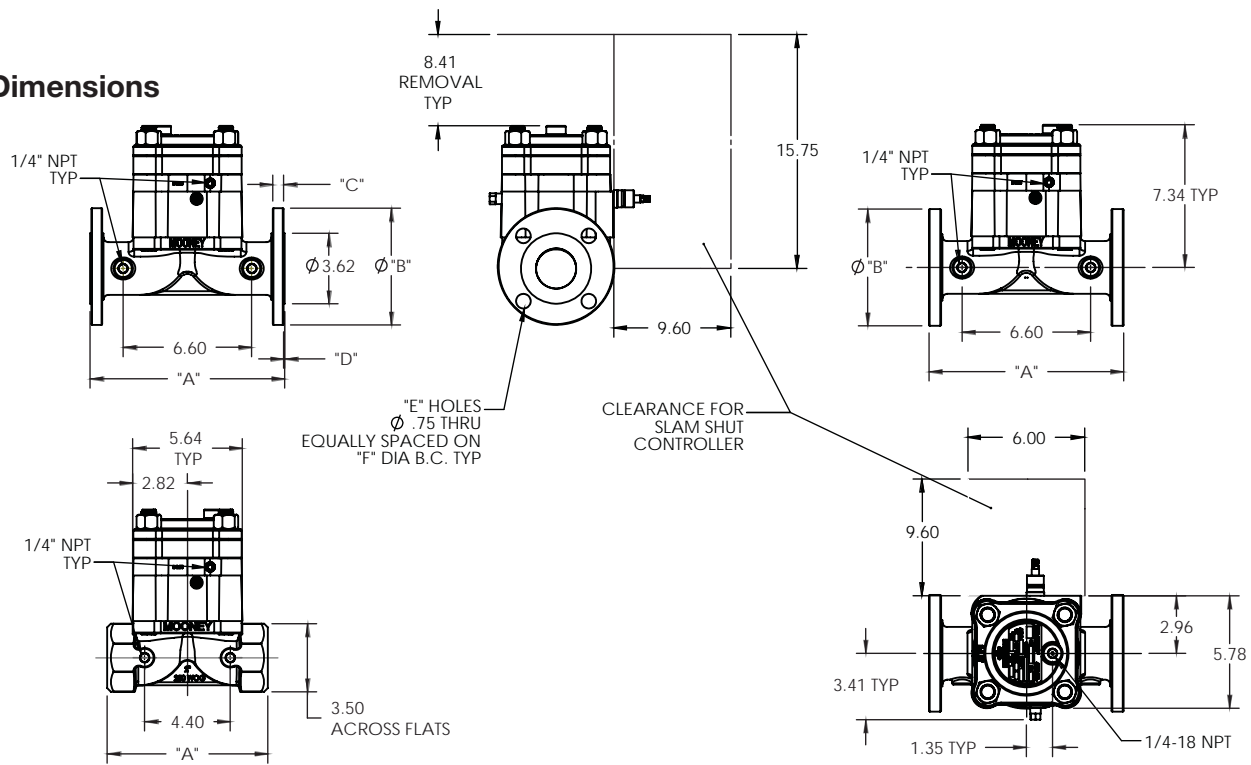

## Flange Dimensions

Flange Class	A	B	C	D	E	F
Class 150	10.00	6.00	.62	.06	4	4.75
Class 300	10.00	6.00	.56	-	4	4.75
NPT/SWE	8.25	-	-	-	-	-

## Flow Coefficients and Constants\*

Percent	2" Flowgrid 250 & Shutoff Valve			Swage Factor	
	C <sub>v</sub>	C <sub>1</sub>	C <sub>g</sub>	1.5:1	2:1
100%	40	40	1600	0.97	0.98
75%	32	38	1230	0.98	0.97
50%	23	35	820	0.99	0.98
35%	16	35	560	1.00	1.00

\* Preliminary Data.

## Minimum Pressure Differential vs. Capacity

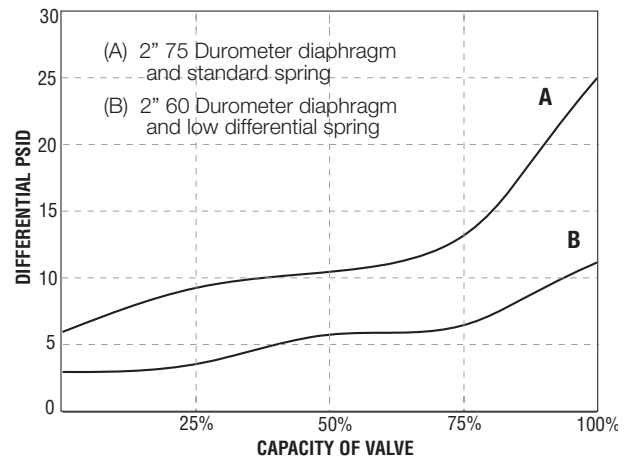

## Diaphragm Selection

Compound	Temp. Range (Degrees F)	Maximum Differential	Characteristics	Recommended Applications
75 Duro	-20 to 150	1000 psid	Best All Around Material	60 psid to Max. Differential
60 Duro	-25 to 150	300 psid	Best Shutoff at Low Differential Pressure	Low Differential (100 psid or less) or Low Temperature

## Dresser, Inc.

2822 S. 1030 W.  
Salt Lake City, Utah 84119  
Phone: 801.487.2225 Fax: 801.487.2587  
www.dresser.com/mooney

