

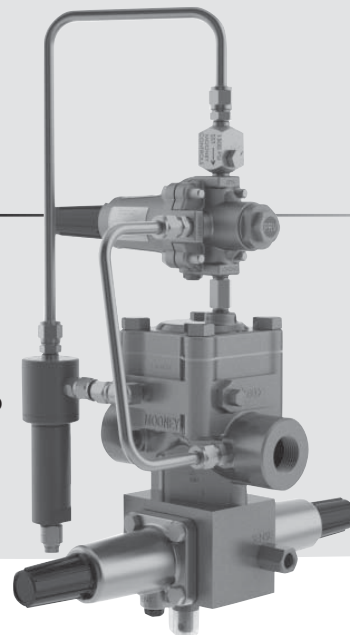

1" & 1-1/4" Flowgrid® Regulator with Shutoff Valve

NPT, SWE, RF

The 1" Mooney Flowgrid Slam Shut is a combination of a regulator and a slam shut. In addition to pressure regulation, this pneumatically actuated device provides automatic downstream pressure protection. By separating the pneumatic controller and mechanical latching mechanism, shut off occurs only when designated set points are reached. The patent pending design prevents disruptive and costly "accidental shutoffs". Positive shutoff is achieved instantly through the snap acting mechanism, and reset can be completed with common tools.



Flowgrid® Regulator with Integral Shutoff Valve, Series 41D Dual Function Controller.

Specifications

Size	1" & 1-1/4"
Body Style	Standard Single Port with Slam Shut
End Connections	1" NPT, 1-1/4" NPT. 1" SWE, 1-1/4" SWE 1" CL 150 RF, 1" CL 300 RF
Temperature*	Working -20°F to 150°F (-29°C to 65°C)
Maximum Differential	740 psig (50 bar)
Minimum Differential	Refer to Graph on pg 2
Cracking Differential	Refer to Graph on pg 2
Maximum Inlet Pressure	740 psig (50 bar)
Outlet Pressure Range	5-450 psig (0.34 - 31 bar)
Flow Direction	Uni-Directional
Taps	Four 1/4" - 18 NPT

*EN 334 and EN 14382 restricts the minimum temperature to -4° (-20°).

Materials of Construction

Valve Body, Bleed Plate & Spring Case	Carbon Steel WCB
Throttle Plate	17 - 4 PH or A515
Slam Shut Seat	SST
Slam Shut Seal	Nitrile
Flowgrid Diaphragm	Nitrile or Viton®
Slam Shut Housing, Slam Shut Spring Case	Aluminum
Spring Cover	Aluminum
Rotating Shaft	SST
Main Shaft Guide	Delrin
End Cap	Lexan
Plug Seal	Nitrile
O-Rings	Nitrile

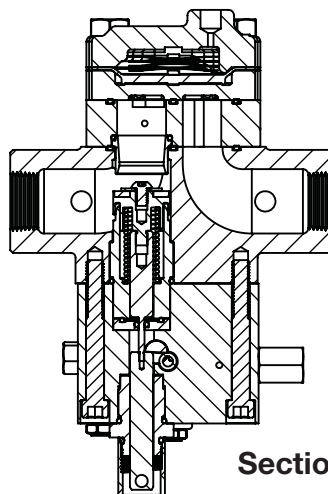

Sectional View

Stock Numbers

1" and 1-1/4" Flowgrid Regulator & Shutoff Valve	Stock Number	Face to Face Dimensions	Weight
1" NPT	SG-123	7.00	21 lbs
1-1/4" NPT	SG-124	7.00	21 lbs
1" SWE	SG-125	7.00	21 lbs
1-1/4" SWE	SG-126	7.00	21 lbs
1" CL 150 RF	SG-127	7.25	21 lbs
1" CL 300 RF	SG-128	7.75	21 lbs

Dimensions

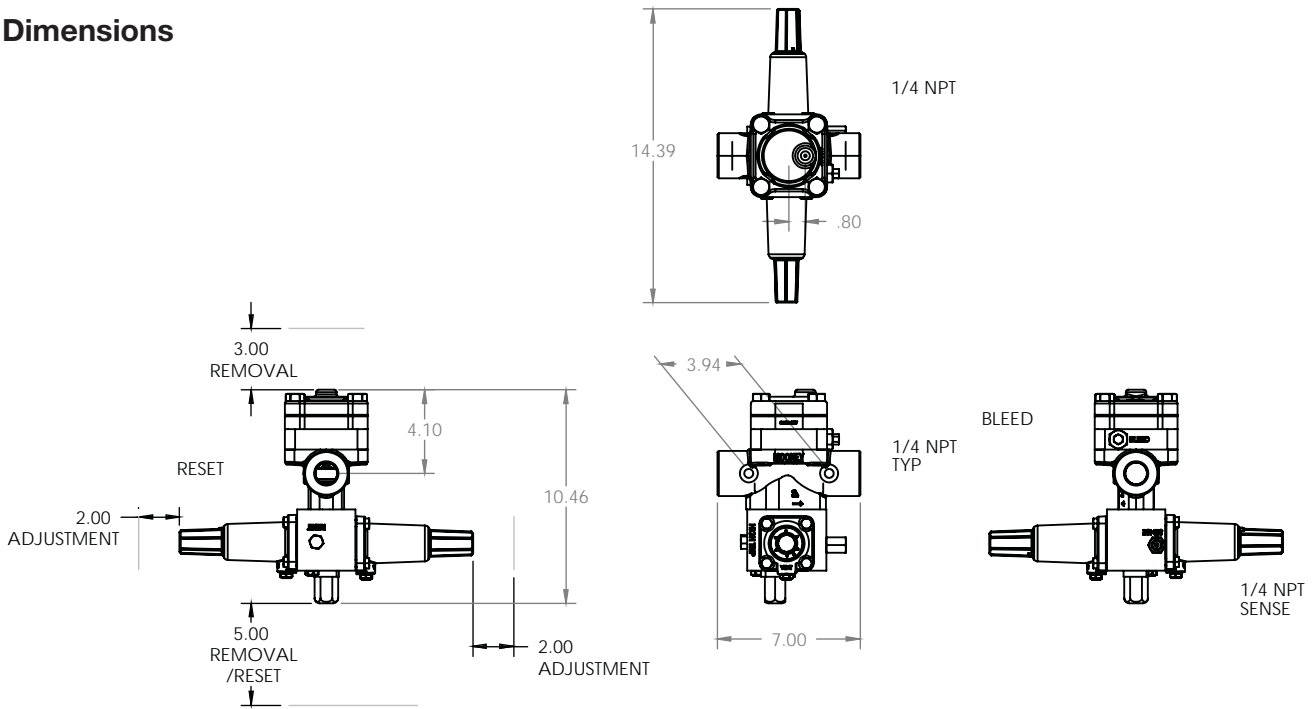

Flow Coefficients and Constants

Percent	1" Flowgrid & Shutoff Valve			Swage Factor	
	C _v	C ₁	C _g	1.5:1	2:1
100%	10.8	38	410	0.96	0.93
75%	8.0	35	280	0.97	0.95
50%	6.7	30	200	0.98	0.96
35%	3.3	30	100	1.00	0.99

Reset NOTE: To reset SSV, sense pressure must be reduced (or increased for Under Pressure) by 20% or more of set pressure.

Preliminary Data

Minimum Pressure Differential vs. Capacity

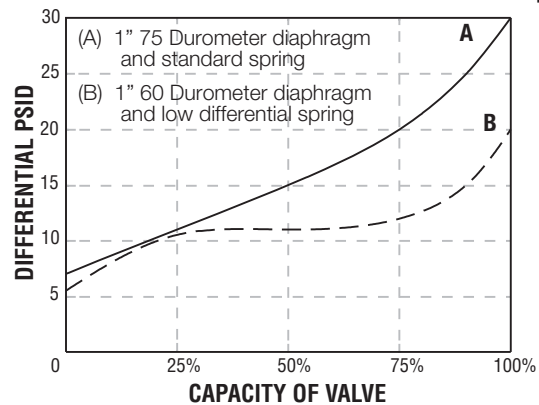

Diaphragm & Plug Seal Selection

Flowgrid Regulator	Compound	Temp. Range (Degrees F)	Maximum Differential	Characteristics	Recommended Applications
Flowgrid Regulator	75 Duro	-20 to 150	1000 psid	Best All Around Material	60 psid to Max. Differential
	60 Duro	-25 to 150	300 psid	Best Shutoff at Low Differential Pressure	Low Differential (100 psid or less) or Low Temperature
	80 Duro High ACN	-5 to 175	1000 psid	Higher Abrasion and Swelling Resistance	High Differential (400 psid or higher) or Abrasive Conditions with Distillates
	80 Duro Low ACN	-20 to 150	1000 psid	Higher Abrasion Resistance and Low Temperature Flexibility	High Differential (400 psid or higher) or Abrasive Conditions at Low Temperatures
SSV Plug Seal	90 Duro Nitrile	10 to 150	740 psid	Best High Pressure Abrasive Material	High Differential Applications or Abrasive Conditions with or without Distillates
	80 Duro Nitrile Low ACN	-20 to 150	740 psid	Best Lower Pressure Low Temperature Material	Low Temperature

Dresser, Inc.

2822 S. 1030 W.
Salt Lake City, Utah 84119
Phone: 801.487.2225 Fax: 801.487.2587
www.dresser.com/mooney

