

## PIC Pressure Instrumentation Column

**The Becker PIC Provides Clean, Dry, Regulated Supply Gas for Your Natural Gas Control Valves and Instrumentation**

### Description

The Becker PIC Series Pressure Instrumentation Column provides regulated and conditioned supply pressures for control valves and instrumentation utilized in natural gas pipeline applications. The PIC regulates full pressure from the natural gas transmission/distribution pipelines and regulates down to various pressure levels required to operate control valves and related instrumentation. The PIC features a fully-welded assembly that is pressure rated to 600 ANSI (standard) and 900 ANSI (optional) pressure. Each PIC is hydrostatically tested to 1.5 times the full ANSI pressure rating. PIC's are available with a variety of options and configurations. Pressure Instrumentation Columns may be equipped with catalytic (flameless) heaters, filter-dryers, instrumentation mounting brackets, and a variety of other optional components. The Becker PIC is the original "Column" designed for use in natural gas transmission/distribution pipelines.



**Figure 1.0** - Becker PIC Series Pressure Instrumentation Column Standard Design

The Becker PIC provides conditioned power supply gas for control valves and instrumentation typically utilized in natural gas distribution & transmission facilities. The PIC provides a single assembly via a single purchase order that minimizes complexity and field work. The PIC is shown with standard configuration and includes optional Catalytic (Flameless) Heater.

### Features

- The Original Pressure Instrumentation Column
- Full-Welded Design Eliminates Threaded Body for Safety and Durability
- Rated to Full ANSI Pressures (600 ANSI and 900 ANSI)
- All PIC's Hydrostatically Tested to 1.5X ANSI Pressure Rating for 4.0 Hours
- Single "Appliance" Provides Complete Supply Gas System
- Fully Tested and Engineered Package Minimizes Field Work
- Standard Square Flange Base Mounts Easily to Concrete Pad/Floor
- Standard Square Flange Base Mounting Bolts to Concrete Pad/Floor
- Not threaded design
- Fully welded construction, X-Ray to API-1104 available
- Many Options and Alternate Configurations Available to Suit Applications Needs

### Why use PIC?

- Complete Supply Gas Conditioning for control valves and control instrumentation.
- No pipeline heater in cold climate
- High pressure drop from pipeline pressure to supply gas pressure.
- Excessive Moisture
- Excessive entrained liquid hydrocarbons (i.e. compressor oil)



**Figure 2.0** - PIC Installed Inside Natural Gas Regulation Facility

The Becker PIC Pressure Instrumentation Column is used to feed heated, filtered, and regulated supply gas to the working control valve (background) and the monitor valve (foreground). The PIC includes the optional Becker FD-1500 Filter-Dryer and Becker FACD-1500 Filter-Deodorizer connected in series to remove any water vapor and liquid hydrocarbons from the supply gas. Line pressure gas is fed into the FACD-1500 and then to the FD-1500 before regulation. This system guarantees proper instrument supply gas to the control systems of both valves to provide long lasting trouble-free service.

**The Becker PIC Pressure Instrumentation Column is a High Performance, High Quality Power Supply Gas System Packaged in a Single System with Guaranteed Performance**

**Low Pressure Regulator**

The Low Pressure Regulator regulates Medium Pressure to Low Pressure of approximately 20 - 60 psig (138 - 414 kPa). The Low Pressure Regulator incorporates an integral filter and pressure relief system.

**Instrumentation Mounting Bracket (Optional)**

The Instrumentation Mounting Bracket provides a convenient location for installation of optional instrumentation or accessories on the PIC. Commonly mounted items include FD-1500 Filter Dryers, FACD-1500 Filter Deodorizers, I/P Transducers, and VRP Valve Regulator Pilots (Pressure Control).

**Low Pressure Reservoir**

The Low Pressure Reservoir serves as a holding chamber for Low Pressure Supply Gas. The chamber enhances the PIC's ability to maintain a capacity of heated, filtered regulated gas. Low Pressure Supply Gas is typically utilized for control instrumentation, control instrumentation accessories, I/P Transducers and low pressure actuators (LD Series).

**Medium Pressure Regulator**

The Medium Pressure Regulator regulates High Pressure (Pipeline) to Medium Pressure of approximately 100 - 350 psig (689 - 2,413 kPa). The Medium Pressure Regulator incorporated is capable of accepting in excess of ANSI rated pressure.

**Medium Pressure Reservoir**

The Medium Pressure Reservoir serves as a holding chamber for Medium Pressure Supply Gas. The chamber enhances the PIC's ability to maintain a capacity of heated, filtered regulated gas. Medium Pressure Supply Gas is typically utilized for control instrumentation and high pressure actuators.

**High Pressure Reservoir**

The High Pressure Reservoir serves as a holding chamber for High Pressure Supply Gas taken directly from the natural gas pipeline. PIC's are available to accept pipeline pressure rated to 600 ANSI (standard) and 900 ANSI (optional). The chamber enhances the PIC's ability to maintain a capacity of heated, filtered regulated gas.

**PIC Mounting Flange**

The PIC is available with three different mounting flanges. The most common mounting flange (shown here) is the "Square Base Surface Mount" flange. The "Square Base" flange allows for easy mounting to solid surfaces such as concrete via a four (4) bolt arrangement. See Page 3 for info. on alternate mounting configurations.

**Flameless Heater Supply Gas Regulator**

The Heater Supply Gas Regulator regulates pressure to 7.0 inches Water Column in order to provide fuel gas for the Catalytic (Flameless) Heater.

\* Catalytic (Flameless) Heater is optional accessory.

**Model FD-1500 Filter Dryer (Optional)**

The optional Becker Model FD-1500 Filter Dryer is available for added security. The FD-1500 provides superior filtration capabilities to 10µ and dehydration capabilities of 3.0 Lbs (1.36 kg) of entrained water. Note that a Model FACD-1500 is also available to remove entrained hydrocarbons (compressor oil) from instrument supply gas.

**Low Pressure Relief Valve**

The Low Pressure Relief Valve provides overpressure protection to minimize potential for damage to components supplied at Low Pressure. The Low Pressure Relief Valve is typically set at 25 - 50 psig (172 - 345 kPa) above customer specified Low Pressure Regulator setpoint.

**Medium Pressure Relief Valve**

The Medium Pressure Relief Valve provides overpressure protection to minimize potential for damage to components supplied at Medium Pressure. The Medium Pressure Relief Valve is typically set at 25 - 50 psig (172 - 345 kPa) above customer specified Medium Pressure Regulator setpoint.

**Catalytic (Flameless) Heater (Optional)**

The Catalytic (Flameless) Heater provides radiative heat source to minimize Joules-Thompson refrigeration effect inherent to pressure reduction of a gas. Catalytic Heaters provide a self-sustaining heat source (6,000 BTU) via flameless combustion of natural gas at +700°F (+371°C). The Catalytic Heater requires electrical activation at startup and provides self-sustaining source of heat without any outside energy source. The Catalytic (Flameless) Heater is rated for use in hazardous areas where natural gas is constantly present.

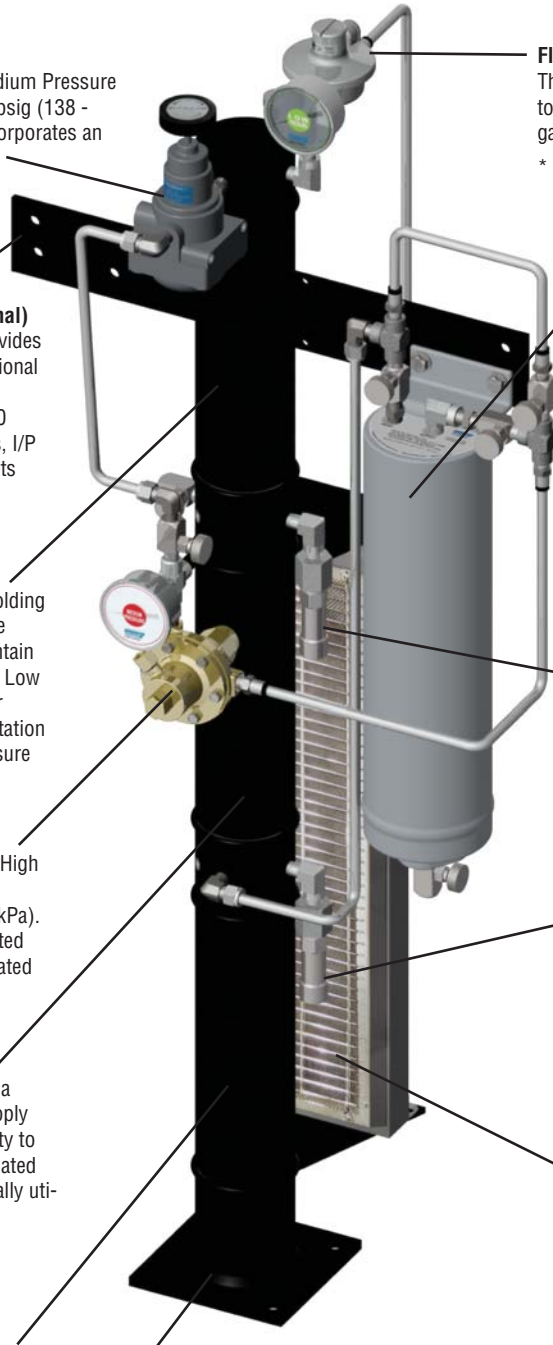

PIC Pressure Instrumentation Column Overall Dimensions

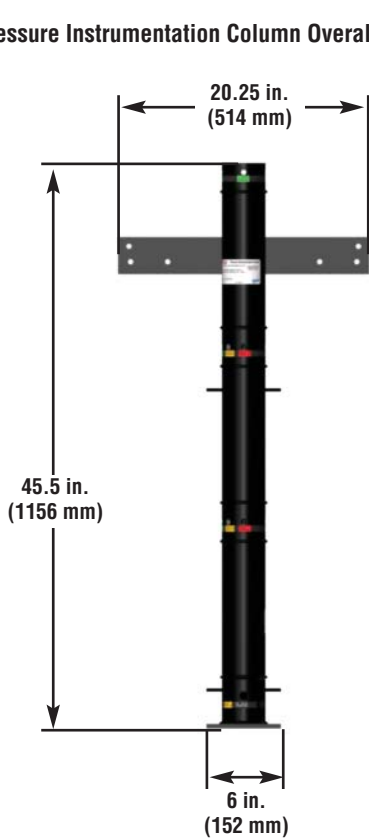

Figure 3.1 - PIC Pressure Instrumentation Column Front View

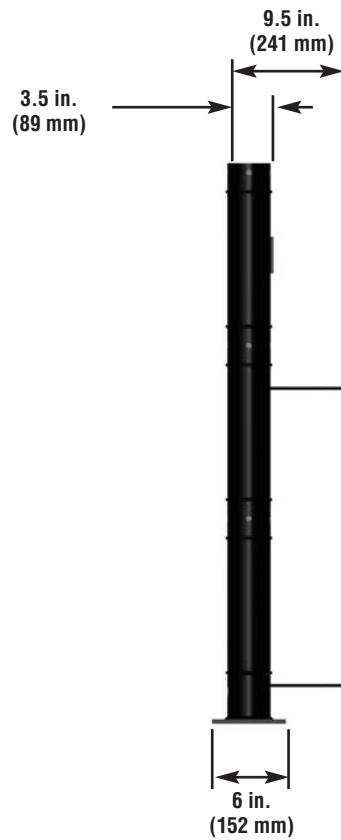

Figure 3.2 - PIC Pressure Instrumentation Column Side View

Notes

- \*PIC Shown with Optional Catalytic (Flameless) Heater Mounting Brackets
- \*PIC Shown with Optional Instrumentation Mounting Bracket

PIC Pressure Instrumentation Column Mounting Configurations (600 ANSI flanges shown).

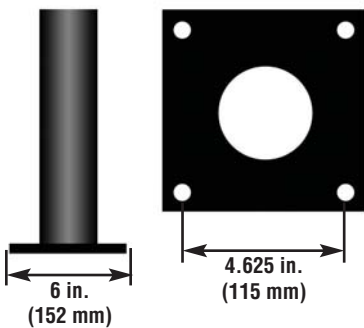

Figure 4.1 - PIC Square Base Mount (Standard)

The Square Base Mount allows surface mount of PIC on any solid surface (concrete) via four (4) bolts. This is the standard PIC mounting arrangement. The High Pressure connection from pipeline is a 1/4 FNPT port at bottom of PIC. Square Base Mount is available in 600 ANSI (standard) and 900 ANSI (Optional) pressure ratings. Mounting dimensions for 600 ANSI and 900 ANSI Square Base Mount are identical per above.

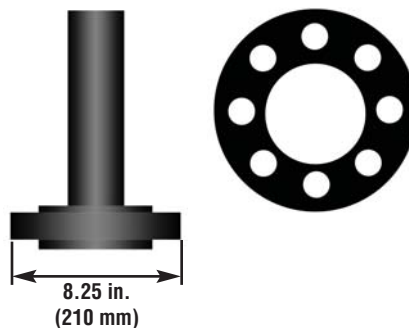

Figure 4.2 - PIC Weld Neck Flange Mount (Optional)

The Weld Neck Flange incorporates a 3 in (75 mm) Weld Neck Flange connection. The Weld Neck Flange option provides flange-to-flange connection and allows finite rotational position of the PIC in 45° increments. The High Pressure connection from pipeline is a very high capacity 3 in (75 mm) pipe. Weld Neck Flange Mount is available in 600 ANSI (standard) and 900 ANSI (Optional) pressure ratings. 600 ANSI Weld Neck Flange is shown above.

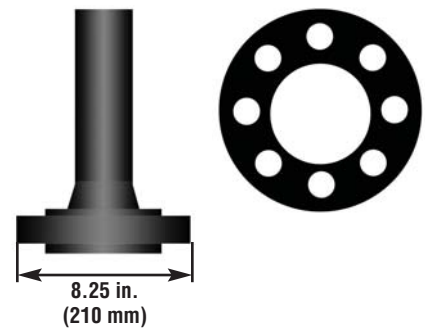
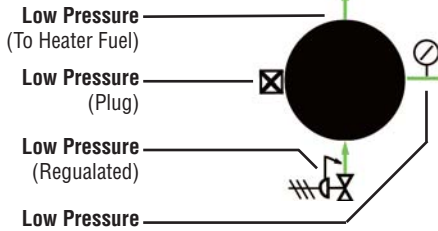

Figure 4.3 - PIC Lap Joint Flange Mount (Optional)

The Lap Joint Flange incorporates a 3 in (75 mm) Lap Joint Flange connection. The Lap Joint Flange option provides flange-to-flange connection and allows infinite rotational position at any desired position. The High Pressure connection from pipeline is a very high capacity 3 in (75 mm) pipe. Lap Joint Flange Mount is available in 600 ANSI (standard) and 900 ANSI (Optional) pressure ratings. 600 ANSI Lap Joint Flange is shown above.

**Figure 5.0 - PIC Pressure Instrumentation Column Port Identification Square Base Mount (Standard)**  
 \*Top View cross sections are shown for each block to facilitate explanation of PIC port configuration.

**Figure 5.1 - Top Block**



**Figure 5.2 - Upper Middle Block**

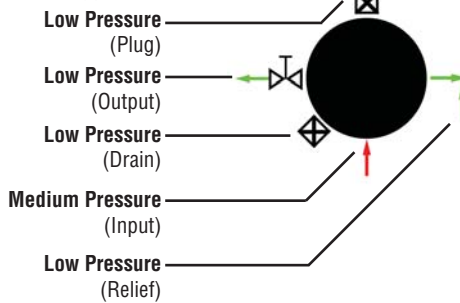

**Figure 5.3 - Lower Middle Block**

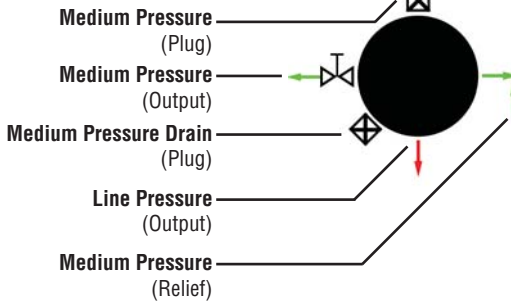

**Figure 5.4 - Bottom Block**

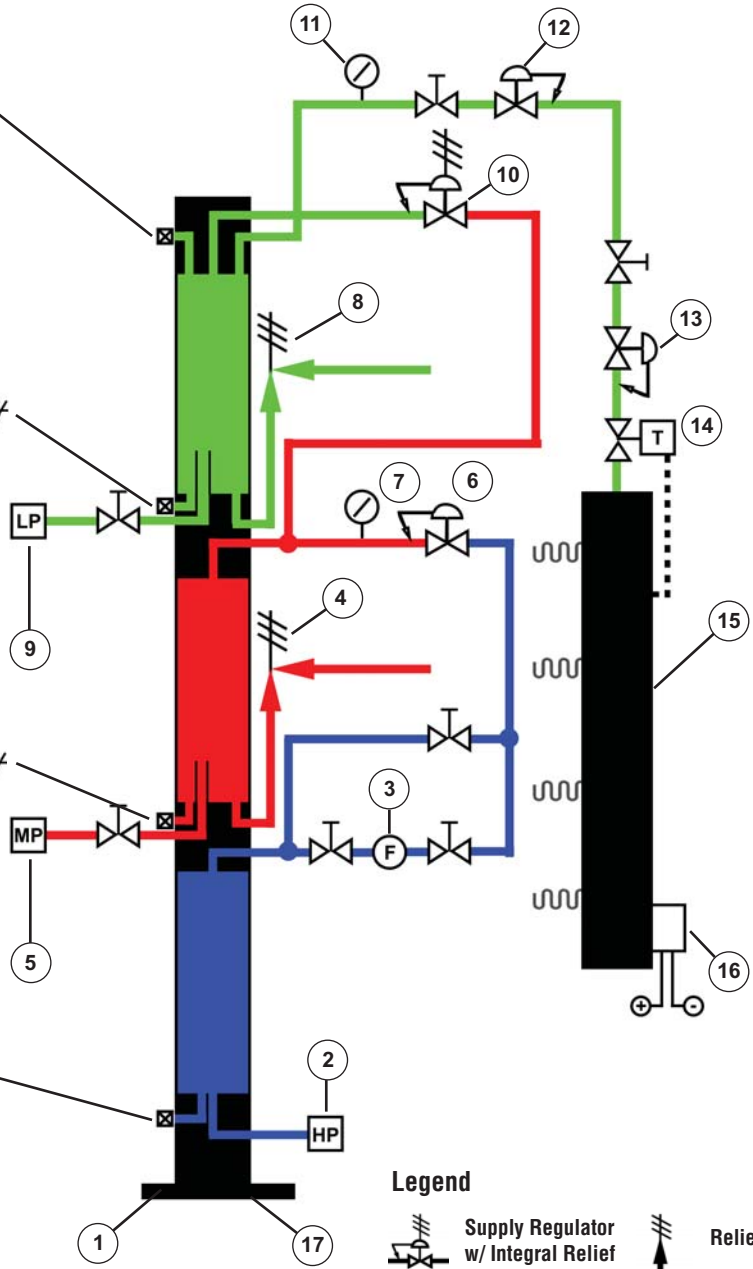
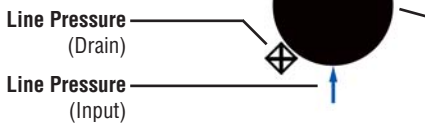

**Legend**

- Supply Regulator w/ Integral Relief
- Gage
- Needle Valve
- Plug
- Thermo Couple
- Relief Valve
- Supply Regulator
- Customer Connection
- Filter-Dryer

**Table 1.0 - PIC Pressure Instrumentation Column Components**

Item	Description	Item	Description
1	Pressure Instrument Column (Body)	10	Low Pressure Supply Regulator
2	High Pressure Connection (In)	11	Low Pressure Supply Gage
3	FD-1500 Filter Dryer (Optional)	12	Heater (1st Stage) Supply Regulator
4	Medium Pressure Relief Valve	13	Heater (2nd Stage) Supply Regulator
5	Medium Pressure Connection (Out)	14	Heater Fuel Supply Thermocouple
6	Medium Pressure Supply Regulator	15	Catalytic "Flameless" Heater
7	Medium Pressure Supply Gage	16	Starting Voltage Connection (In)
8	Low Pressure Relief Valve	17	Mounting Flange
9	Low Pressure Connection (Out)		

# PIC Pressure Instrumentation Column

**Figure 6.0 - Typical Installation Schematic for PIC Pressure Instrumentation Column**

The PIC Pressure Instrumentation Column is shown in a typical installation with a Becker Control Valve and relevant instrumentation components. The PIC provides all necessary pressure levels of instrument supply gas necessary to operate all components.

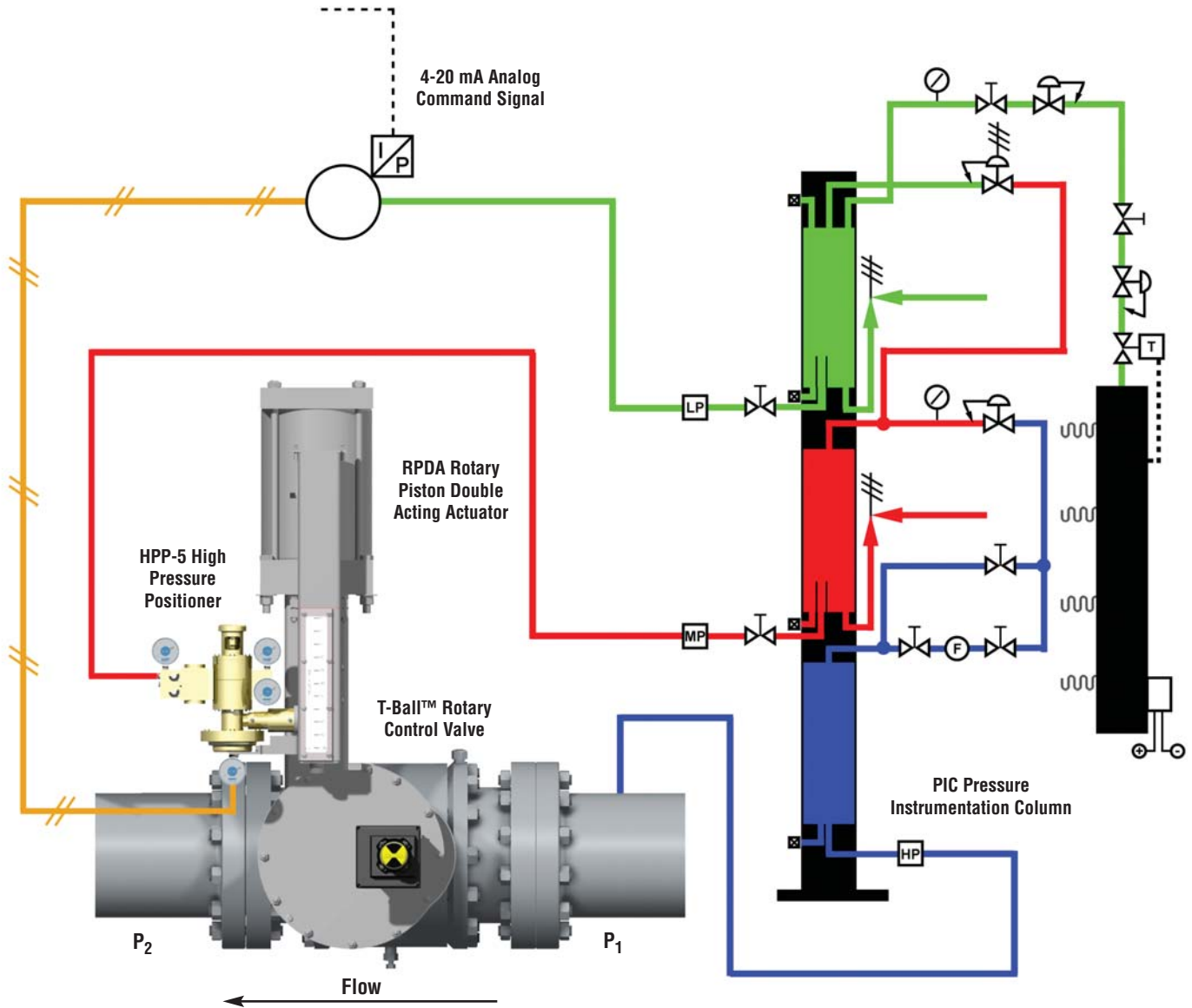

**Schematic Legend**

- Low Pressure Power Gas
- Medium Pressure Power Gas
- Line Pressure
- Signal Pressure

**Legend**

- |  |                                     |  |               |  |                     |
|--|-------------------------------------|--|---------------|--|---------------------|
|  | Supply Regulator w/ Integral Relief |  | Plug          |  | Supply Regulator    |
|  | Gage                                |  | Thermo Couple |  | Customer Connection |
|  | Needle Valve                        |  | Relief Valve  |  | Filter-Dryer        |



**Figure 7.0 - Dual PICs Installed in Becker CAB Series Fiberglass Enclosure**  
 Two Becker PIC Pressure Instrumentation Columns are installed inside a Becker CAB Fiberglass Cabinet. Each PIC provides conditioned and regulated supply gas to a Becker control valve, one PIC for the working control and one PIC for the monitor control valve. Each PIC also includes the optional Becker FD-1500 Filter-Dryer to remove moisture from the supply gas. The fiberglass enclosure is required to prevent the catalytic heaters from extinguishing during inclement weather. Each catalytic face heater is hard wired with 120 V A.C. starting voltage and each disconnect is also located inside the fiberglass enclosure.



**Figure 8.0 - Single PIC Installed in Becker CAB Series Fiberglass Enclosure**  
 A Becker PIC Pressure Instrumentation Column is installed inside a Becker CAB Fiberglass Cabinet. The PIC provides conditioned and regulated supply gas to four tube switching valves. The outputs to the tube switching valves are located in the upper left corner of the cabinet. The PIC includes optional dual FD-1500 Filter-Dryers complete with independent regulation systems to meet higher capacity requirements. Each FD-1500 and regulator set feeds a pair of the tube switching valves. The PIC system also includes the optional stainless steel components to comply with specific customer requirements of no brass material in the system. The catalytic face heater is hard wired with 120 V A.C. starting voltage complete with the disconnect located inside the fiberglass enclosure.

### PIC Pressure Instrumentation Column Accessories

Realize Optimum Performance of your PIC Pressure Instrumentation Column with these popular accessories!



#### Becker Model FD-1500 Filter Dryer

The Becker Model FD-1500 Filter Dryer filters and de-hydrates supply gas for all Becker Control Instrumentation. The FD-1500 Filter-Dryer provides superior filtration and dehydration with 110 square inches of 10 micron filtering media and 2.0 pounds of silica gel. The FD-1500 incorporates an easy-to-replace "spin on" cartridge made up of a high quality, high capacity nylon and fiberglass filter element reinforced with stainless steel mesh. All FD-1500's are fully Hydrottested to 1.5 times the working pressure to ensure the integrity of the pressure vessel.



#### Becker Model FACD-1500 Filter Dryer

The Becker Model FACD-1500 Filter Dryer filters and removes hydrocarbons odor from supply gas for all Becker Control Instrumentation. The FACD-1500 Filter-Dryer provides superior filtration with 110 square inches of 10 micron filtering media and 2.0 pounds of activated charcoal. The FACD-1500 incorporates an easy-to-replace "spin on" cartridge made up of a high quality, high capacity nylon and fiberglass filter element reinforced with stainless steel mesh. All FACD-1500's are fully Hydrottested to 1.5 times the working pressure to ensure the integrity of the pressure vessel.



#### Becker Fiberglass Cabinet (CAB)

The Becker Fiberglass Cabinet is ideal for the safe enclosure of Becker below grade regulators, pressure instrumentation columns, and other regulating station equipment. The cabinet is particularly useful in areas of extreme weather or fluctuating elemental conditions. When regulating components must be heated, the cabinet minimizes ambient heat loss. Flip top cover protects technical personnel during routine maintenance.



#### Becker Thermal Check Valve (TCV)

The Becker Thermal Check Valve (TCV) is designed for use with regulated natural gas supply systems. The Thermal Check Valve offers simple and inexpensive insurance against fire in natural gas regulating stations, compressor stations, or other areas where regulated natural gas supply systems are present. The Valve stops the flow of combustible natural gas into potentially hazardous areas in the event of fire or excessive heat.



#### Catalytic (Flameless) Heater

For PIC applications where freezing may be a problem, the Catalytic (Flameless) Heater is an ideal accessory. The Catalytic (Flameless) Heater provides continuous, flameless heat to PIC and related instrumentation without external power sources, except at heater startup. The catalytic technology operates at a temp. of 600°- 800°F, ensuring a safe, reliable source of heat. Catalytic (Flameless) Heater startup voltages are available in both  $\pm 24$  VDC and 110 VAC and are available with both CGA and FM approval ratings. Unit includes all necessary regulation and components for easy operation.

#### Other Available Options

The Becker PIC Pressure Instrumentation Column is available with a variety of options and accessories to suit your applications needs. For more information on these options and accessories, contact Becker.

- High Pressure Design (900 ANSI)
- High Volume Capacity Design
- Multiple Mounting Arrangements
  - PIC Square Base Mount (Standard)
  - PIC Weld Neck Flange Mount (Optional)
  - PIC Lap Joint Flange Mount (Optional)
- Stainless Steel Component Construction
- Radiographic (X-Ray) Testing of Pressure Vessel
- Square Base Extension Pedestal (Elevate PIC)
- Custom Instrumentation Mounting Brackets
- Catalytic (Flameless) Heater Shroud
- Custom Paint/Coating

Specifications	
Item	PIC Series Pressure Instrumentation Column
Classification	Supply Gas System
MAOP	600 ANSI 1480 psig (10,204 kPa) 900 ANSI 2175 psig (14,996 kPa)
Flow Capacity	50 SCFM (1.4 std. m <sup>3</sup> / min) - Standard PIC Design
Inlet (Line Pressure) Port	½ FNPT (Standard Square Base Flange Mount) 3 in. port (Lap Joint Flange Mount) 3 in. port (Weld Neck Flange Mount)
All Other Ports:	1/4 FNPT
Weight:	20 Lbs. (9.0 Kg) Standard Square Base, Flange Mount PIC - 600 ANSI
Supply Gas Regulator	Med. Pressure Regulator: 100-350 psig (689-2,413 kPa)
Typical Pressure Ranges	Low Pressure Regulator: 20-60 psig (138-414 kPa)
Heater Supply Regulator (Optional)	7.0 in Water Column
Temperature Range:	-20°F to +160°F (-29°C to +71°C)
Materials of Construction	
PIC Body	Carbon Steel
Isolation Valves	Plated Steel Needle Valves (Standard)
Gages	2.5 in. Diameter Liquid-Filled Gages (standard)
Fittings	Plated Steel (Standard)
Tubing Fittings	Dual Ferrule 316 SS
Tubing	316 SS Seamless
Relief Valves	Plated Steel
Med. Pressure Regulator	Painted Cast Aluminum (Standard)
Low Pressure Regulator	Brass (Standard)
Catalytic Heater Fuel Supply Regulator	Cast Aluminum (Standard)
Available Mounting Arrangements	600 ANSI Square Base Flange Mount (Standard) 900 ANSI Square Base Flange Mount (Alternate) 600 ANSI Weld Neck Flange Mount (Alternate) 900 ANSI Weld Neck Flange Mount (Alternate) 600 ANSI Lap Joint Flange Mount (Alternate) 900 ANSI Lap Joint Flange Mount (Alternate)
Hydrostatic Testing	600 ANSI Design - 2220 psig (15,306 kPa) for duration of 4.0 Hours 900 ANSI Design - 3263 psig (22,494 kPa) for duration of 4.0 Hours
Catalytic Heater (Optional)	
Heater Type	Self-Sustaining Catalytic (no outside power source required after initial ignition)
Fuel Type	Natural Gas
Fuel Supply Pressure	7.0 in WC
Heat Output	6,000 BTU
Available Ignition	12 VDC or 120 VAC
Voltages	
Electrical Classification Options	FM Approved - Class 1-Division 2-Group D locations by Factory Mutual Research CGA Approved - Class 1-Division 1- Division 2-Group D locations by the Canadian Gas Association
Safety Shutoff	All catalytic heaters are quipped with Thermocouple safety shutoff valves



**Figure 9.0** - PIC Installed Inside Pressure Limiting Station Building

A Becker PIC Pressure Instrumentation Column is located inside a station building to provide complete supply gas conditioning to an adjacent Becker monitor control valve. The PIC includes the optional Becker FD-1500 Filter-Dryer and Becker FACD-1500 Filter-Deodorizer connected in series to remove any water vapor and liquid hydrocarbons from the supply gas before entering the regulation stages. The catalytic face heater requires 12 V D.C. or 110 V A.C. starting voltage. Note the extension cord receptacle located at the rear of heater. This complete PIC system eliminates common problems associated with instrument supply gas such as freezing, liquids, and particulate.

**Becker Precision Equipment  
Dresser, Inc.**

1550 Greenleaf Avenue  
Elk Grove Village, Illinois 60007 USA  
Ph: 847.437.5950 Fax: 847.437.2549  
Toll Free Phone: 800.323.8844 Email: becker@dresser.com  
©2008 Dresser, Inc.  
Becker, and DRESSER are registered trademark(s) of Dresser, Inc.



[www.dresser.com](http://www.dresser.com)