

## Below Ground Ball Valve Regulators

Below Ground Ball Valve Regulators are Designed for Large Volume Regulator Stations Requiring Reduced Noise Levels



**Figure 1** - Installation of Becker Below Ground Ball Valve Regulator.

Becker Below Ground Ball Valve regulators may be installed to achieve maximum noise attenuation, minimal maintenance, and optimum cost effectiveness. The Below Ground Regulator can provide up to 37 dBA noise attenuation with minimal additional costs.



Michael E. Hogan served as Chief Engineer for a major midwestern gas utility for 36 years and is now retired. The following is an independent study based on his personal experience with the equipment.

### Introduction

In recent years, there has been growing concern within the natural gas industry regarding the effect natural gas regulating stations have on their surrounding environments. In an effort to cut down on excessive noise and pollution, many gas distribution and transmission companies have begun utilizing equipment, which reduces the impact on the surrounding environment. The Below Ground ball valve regulator is a prime example of this environment friendly equipment. Because of its high capacity, control capabilities, rangeability, and dependability,

---

**“...the Below Ground ball valve regulator has become the preferred method for controlling gas flow through natural gas regulating stations...”**

---

It remains the primary choice for high volume regulation throughout the gas industry. Its long term reliability warrants further consideration for the direct burial of the ball valve regulator as a method of, not only maintaining superior flow characteristics, but also of greatly reducing any noise created in the station facilities.

## A Brief History

The history of the ball valve regulator, as it is configured today, began in the middle 1950's when a plug valve was adapted to a piston, positioner, and pneumatic controller. Although this early type of regulator was able to control the flow of gas, it had numerous drawbacks, such as high and variable torque requirements and jerky operation (which resulted in rough pressure or flow control). To overcome some of these problems, the plug valve was replaced with the sliding gate (Okadee) valve. This newer system resolved some of the problems associated with plug valve operation, but also created some problems of its own. Problems associated with the sliding gate valve involved high breakaway torque requirements and poor locking capabilities while the valve was in the closed position. The final step in the evolution of the ball valve regulator was the adaptation of the standard ball valve. Throughout the last several decades, the ball valve has undergone steady improvements in design and construction, bringing the ball valve regulator to the level at which it is utilized today.



## Construction

The superiority of the modern ball valve regulator as a means of flow control starts with the quality construction of each regulator component. The ball valve is smoothly machined and polished to provide low breakaway requirements. This allows for very accurate control. All connecting links, bearings, crank arms, etc. are made of high quality material and machined to close tolerances. This minimizes lost motion and results in the long, dependable service of each individual part. The pneumatic cylinder is built of high quality components, which will provide many years of reliable total regulator service. Finally, the control system may consist of the standard pneumatic controller/positioner system or the newer pilot control system. The pilot control system is capable of discharge to a downstream pressure system, which completely eliminates atmospheric bleed.

---

**“...components, which make up the complete ball valve regulator package work together to comprise a system more than capable of handling the strict needs of the gas industry..”**

---

In order to take full advantage of the operating capabilities of the ball valve regulator, careful consideration must take place in the station design.

**Figure 2** - Below Ground Ball Valve Regulator combined with Control Valve Silencer.

The Below Ground Ball Valve Regulator may be combined with other noise attenuating devices in order to achieve additional noise attenuation. Noise Attenuating Control Valves, Control Valve Silencers, and Control Valve Diffusers may be combined with Below Ground Regulators for additive noise attenuation when conditions require extreme noise attenuation. Notice Becker Model CVS Control Valve Silencer installed at outlet flange of Below Ground Regulator prior to backfill of pipeline trench.

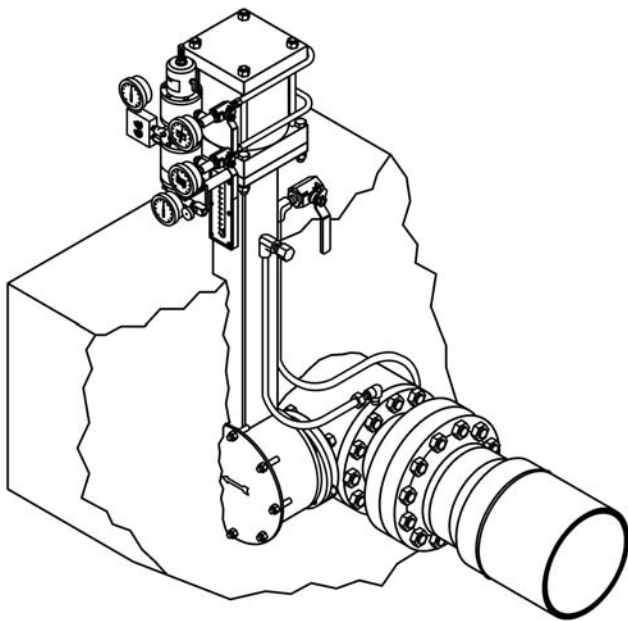

**Figure 3** - Below Ground Regulator Design Permits Easy Maintenance.

The Below Ground Regulator incorporates lubrication line and drain line extensions on the control valve that allow for maintenance and/or operational checks. The typical life span of a Below Ground Regulator is in excess of twenty years.

### Design Considerations

Because of the high capacities with which a ball valve regulator operates, extreme care should be taken in the design phase of the regulator station. Maximum gas flow velocity calculations should be made for regulator run piping. Maximum velocities should be maintained below 100 fps for above ground piping and below 200 fps for below ground piping. These velocity standards are based on information gathered from field experience with numerous stations over long periods of time. Stations, which had excessive velocities, typically experienced vibration problems. Adhering to the velocity standards indicated above should eliminate vibration and its associated mechanical damage. Furthermore, lower gas velocities result in lower noise levels and less pressure drop in the station piping.

Regulator capacities are greatly affected by the configuration of the regulator run. Major design considerations should include the following:

- 1) Whether or not a monitor regulator will be used for over-pressure protection. In large volume regulator stations, monitor regulators are preferred over relief valves. Over-pressure protection prevents the emission of large volumes of natural gas to the atmosphere in the event of any malfunction of the primary control element.
- 2) The relative size of the inlet and outlet piping in relation to regulator size. The ratio between regulator run piping and the regulator should not exceed 3:1.
- 3) Relative size of block valve. Block valve size should equal station inlet/outlet pipe size. Regulator capacities should always be verified by the manufacturer for accuracy.

A consideration often overlooked in station design has to do with the noise created by the flow of gas through the regulator. The designer must be aware that all regulators create noise and must make attempts to alleviate it. Valve sizing software is available through many regulator manufacturing companies and can aid greatly in station design. This software contains formulas, which can be used to accurately predict regulator noise levels.

OSHA has mandated ear protection requirements for various noise levels and exposure duration. Noise generated by regulators may also go beyond station boundaries and become an irritant to neighbors and passersby.

There are many methods of treating noise such as: extra-heavy pipe, pipe wrap, downstream silencers, quiet trim valves, regulator run enclosure buildings, etc. Unfortunately most of these methods offer only a partial, and rather costly, solution.

---

**“...By utilizing the Below Ground ball valve regulator, the designer is able to solve the noise problem with little to no increase in cost...”**

---

(It should also be noted that the use of the Below Ground Ball Valve Regulator takes up less space, thereby reducing the size of any needed enclosure buildings).

Burial of regulator piping results in a noise reduction of 25 to 37 dBA depending upon burial depth. This reduction is normally enough to eliminate any ambient noise problems.

### Field Examples

Two randomly selected stations were tested with sound measurement equipment to compare actual field conditions with the calculated predicted noise attenuation between above ground and below ground regulator runs.

Station one originally incorporated 4" above ground regulators with a flow of 2.4 MMscfh and 157 psi outlet pressure. The noise level on station one was measured at 106 dBA for the above ground regulators. During major station revision, 8" valve regulators were installed below ground and sound readings were taken with a flow of 2.9 MMscfh. The newer sound level readings registered at 77 dBA, which was reduction of 29 dBA. Sound level calculations predicted a sound level of 86 dBA, which ultimately proved to be very conservative.



**Figure 4 - Below Ground Regulator with Fiberglass Cabinet.**

Control valve actuator topworks and control instrumentation may be conveniently enclosed in a small fiberglass cabinet for security and protection from the elements. The small size of the cabinet enclosure typically eliminates the need for building permits and reduces overall costs.

In station two, parallel regulator runs, identical in size, were installed. One run was installed above ground, and the other below ground. Although these runs were not designed under today's guidelines, they do offer a good comparative example. With a flow of approximately 10.0 MMscfh, a noise reduction of 27 dBA was achieved in the below ground run. At a high flow of 28.0 MMscfd a noise reduction of 34 dBA was achieved. No costly methods of noise attenuation were needed other than that provided by the earth itself.

There have been numerous field tests done to obtain noise readings on several below ground stations. These readings were compared to the calculated noise levels predicted for the stations if they were to be installed above ground.

Test Case	A	B	C	D	E
Flow (Mcfh)	1180	2720	775	173	7800
Inlet Pressure (psig)	467	398	565	416	393
Outlet Pressure (psig)	154	60	275	151	155
Actual Noise (dBA) Below Ground	82 dBA	70 dBA	<70 dBA	72 dBA	86 dBA
Calculated Above Ground Noise (dBA)	108 dBA	117 dBA	91 dBA	96 dBA	118 dBA
Actual Below Ground Noise Attenuation (dBA)	26 dBA	47 dBA	>21 dBA	22 dBA	32 dBA

**Table 1** - Resultant Noise Attenuation for Below Ground Ball Valve Regulator Applications.

The Below Ground Ball Valve Regulator can typically provide between 25-37 dBA over above ground applications. Note that the actual noise attenuation for these particular below ground regulator stations ranged from 21 dBA to 47 dBA. Actual below ground noise attenuation is contingent upon buried depth and soil mechanics.

In 1992, a high volume regulator station was installed in order to supply gas to a power plant. The station consisted of three parallel Below Ground Ball Valve Regulator runs (one of which was on standby) using 10" ball valves (primary and monitor), with 16" inlet piping, 24" outlet piping, 30" headers, and a small start up/pilot gas regulator run of 4" boot-type regulators. Pipeline pre-heaters and orifice meters completed the station, giving an overall flow capacity of 28 MMscfh. Maximum noise levels were predicted at 127 dBA (maximum flow) for above ground and 93 dBA for below ground. Noise tests were recently taken at this station. With a volume of 4.7 MMscfh flowing through the station (approximately 75% through a buried ball valve regulator and 25% through the boot-type regulator), the noise level at the buried ball valve regulator was 85 dBA. If this were an above ground regulator, the predicted noise level would be 109 dBA. 220 feet downstream of regulation, the station's piping returns above ground to go through a series of liquid separators. A reading of 84 dBA was taken at this point. This reading showed a 25 dBA drop from the sound level predicted from an above ground regulator. Even at low flows this test indicates that a large portion of the regulator noise is absorbed by the earth as the gas moves downstream. There is obvious noise attenuation as the distance from the noise source increases.

Distance from Noise Source (feet)	Reduction of (dBA)
20	7
40	10
60	17

**Table 2** - Noise Attenuation as a factor of distance from the noise source.

Audible noise further attenuated when measured from a distance from the noise source. Common designs specify "allowable noise" at the "property line" or "fence line" thus providing additional noise attenuation.

If noise levels are in the 70 dBA range at the regulator, and the property line is 40 to 50 ft. away, any noise resulting from regulation would be indistinguishable from normal background noise levels.

Cost savings may be realized with use of the Below Ground Ball Valve Regulator. This is due to the smaller piping (and therefore smaller block valves) which may be used for the higher velocities that are allowed below ground (200 fps vs. 100 fps above ground).

### Noise Attenuation as Factor of Below Ground Depth

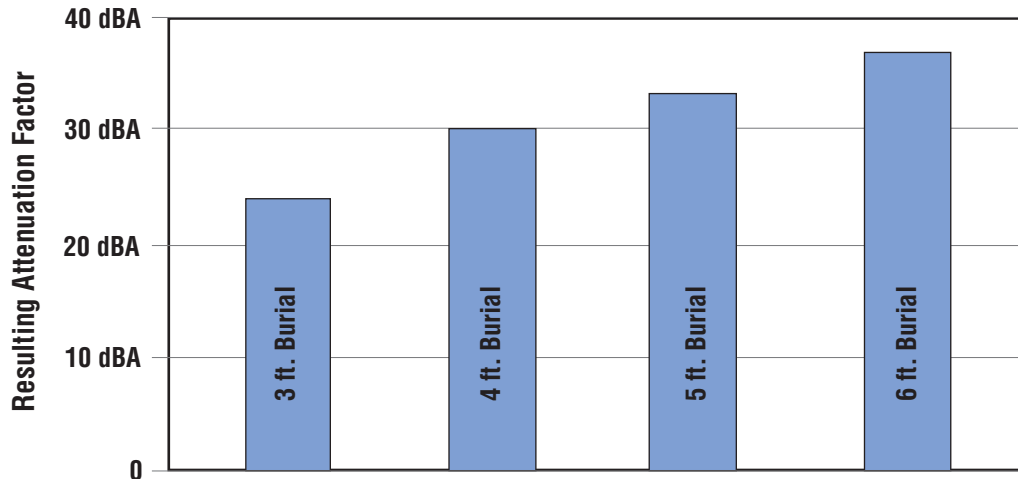

**Figure 5** - Noise Attenuation as Factor of Depth.

Typical below ground depths range from 3 feet burial to 6 feet burial. The below ground depth is measured from centerline of pipe to grade. Below Ground noise attenuation usually provides from 25 dBA to 37 dBA noise attenuation for these buried depths.

In addition there is a small gain in station capacity as well as a cost savings in the elimination of need for the fitting installation necessary for above ground regulators. A number of pipe support posts may also be eliminated by moving the regulators underground. Only small concrete pads are necessary for below ground support. In addition to the cost savings, noise level is substantially reduced. For example, a theoretical station is to be designed to regulate 2.0 MMscfh with an inlet pressure of 450 psi and an outlet of 150 psi. A regulator run was sized for above ground and below ground installation with the results listing in Table 3.

**“...regulator burial not only substantially reduces noise levels but does so at a reduced cost...”**

It thus becomes apparent that one concern regarding the Below Ground Ball Valve Regulator is that burying regulators simply “hides” the noise and that serious damage may be caused to downstream piping. These concerns are unfounded as there are many buried valve regulator stations that have been in service in excess of thirty years without mechanical problems involving the downstream piping.

Measurements indicate that the generated noise is actually absorbed by the soil surrounding the pipe. A buried valve regulator station was tested to check this theory.

	Above Ground	Below Ground
<b>Flow</b>	2.0 MMscfh	2.0 MMscfh
<b>Inlet Pressure</b>	450 psi	450 psi
<b>Outlet Pressure</b>	150 psi	150 psi
<b>Regulator Size</b>	4”	4”
<b>Inlet Hdr.</b>	6”	6”
<b>Inlet Block Valve</b>	6”	6”
<b>Inlet Velocity</b>	87 fps	194 fps
<b>Outlet Hdr.</b>	10”	8”
<b>Outlet Block Valve</b>	10”	8”
<b>Outlet Velocity</b>	94 fps	137 fps
<b>Calculated Noise Level</b>	109 dBA	85 dBA

**Table 3** - Comparison of Theoretical Design of Above Ground versus Below Ground Regulator Station

Calculated noise for above ground station is 109 dBA, while calculated noise for the below ground station is 85 dBA. The below ground station should provide 24 dBA noise attenuation based upon calculations. Note that smaller adjacent piping and block valves may be utilized for Below Ground Regulator installations, resulting in lower costs.

The noise level at the buried regulator was 76 dBA. The predicted noise level was calculated at 82 dBA for the below ground regulator and 106 dBA for the above ground regulator. The pipe was exposed 10 ft. downstream of the regulator where the noise level registered at 96 dBA. This indicates a 10 dBA drop from the predicted noise level for above ground regulators.

<b>Actual Below Ground Noise Level</b>	76 dBA
<b>Predicted Below Ground Noise</b>	82 dBA
<b>Predicted Above Ground Noise</b>	106 dBA
<b>Actual Reading with Pipe Exposed (10 ft. downstream of regulator)</b>	96 dBA
<b>Noise Attenuation Due to 10 ft. of Buried Pipe</b>	10 dBA

**Table 4 -** Below Ground Regulators Attenuate Noise Even When Pipe Does Not Remain Buried.

Noise readings were taken at a Below Ground Regulator with downstream piping exposed. The actual noise reading at an excavated point suggest that 10 feet of buried piping provided approximately 10 dBA of noise attenuation. This suggests that the Below Ground Regulator does provide a "source attenuation" thereby eliminating noise over a length of buried pipe.

Further testing will be done in this station, but preliminary studies indicate that, although some noise is transmitted downstream, a large amount is also absorbed by the soil surrounding the pipe. If it becomes necessary to bring the piping above ground down-stream of regulation (for metering, etc. ) an alternate option would incorporate a Below Ground Ball Valve Regulator with a noise attenuating ball control valve. Proper design and reduction of velocities within the prescribed limits will minimize any problems.

## Maintenance and Inspection

The maintenance procedures for a buried ball valve regulator are quite similar to those for above ground installations. A direct quote from the code of Federal Regulations regarding maintenance, Part 192.739 reads:

### **Pressure limiting and regulating stations: Inspection and testing.**

Each pressure limiting station, relief device (except rupture discs), and pressure regulating station and its

equipment must be subjected at intervals not exceeding 15 months, but at least once each calendar year, to inspections and tests to determine that it is:

- (a) In good mechanical condition;
- (b) Adequate from the standpoint of capacity and reliability of operation for the service in which it is employed;
- (c) Set to function at the correct pressure;
- (d) Properly installed and protected from dirt, liquids, or other conditions that might prevent proper operation.

---

**“There are no federal requirements that dictate the need for the physical internal inspection of any regulator. This includes ball valves...”**

---

There are no federal requirements that dictate the need for the physical internal inspection of any regulator. This includes ball valves as well as globe type regulators, boot-type regulators, etc. The trend of the gas industry over the last decade has been to minimize inspection of the internal regulator body, overhaul the regulator control system-pilots, pneumatic controllers, positioners, etc. and check the entire system for proper operation.

As far as ball valve regulator inspection is concerned, very few companies inspect the ball internally on an annual basis. This is generally the case regardless of whether the regulator is above or below ground. Valve leakage can be checked on a proper installation by use of pipe blow offs and block valves. As far as normal maintenance, the control system should be checked and parts replaced as necessary. The only remaining parts requiring inspection are those associated with the linkage, crank arm assembly, etc. The procedure for checking for wear in these areas is called "lost motion" inspection. "Lost motion" is easy to spot and should not be experienced for many years.

These maintenance procedures, as explained, are the same for both below ground and above ground ball valve regulator installations. Furthermore, there is no additional cost for man-power or testing associated with the Below Ground Regulator.



## Conclusion

The ball valve regulator has served the gas industry extremely well over the last 30 to 40 years. Because of its long term proven reliability, high quality construction, noise attenuating capabilities, and simple maintenance, the Below Ground Ball Valve Regulator is the ideal choice for the regulation of natural gas and should be considered a strong and viable alternative for station designers and operators.

---

### **Becker Precision Equipment Dresser, Inc.**

1550 Greenleaf Avenue  
Elk Grove Village, Illinois 60007 USA  
Ph: 847.437.5940      Fax: 847.437.2549  
Toll Free Phone: 800.323.8844      Email: [becker@dresser.com](mailto:becker@dresser.com)



[www.dresser.com](http://www.dresser.com)