



RPSR Rotary Spring Return Actuator

Heavy Duty Control Valve Actuator for Applications that Require Guaranteed Failure Mode





RPSR Rotary Spring Return Actuator

Description

The RPSR Rotary Piston Spring Return Actuator is designed for heavy duty control applications that require optimum performance. The RPSR is typically utilized when applications require the control valve to fail-open or fail-closed upon loss of power supply gas. The RPSR incorporates a crank-arm mechanism specifically designed for the rigors of throttling control valve applications. The RPSR can accept high pressure power supply gas up to 500 psig (3447 kPa) enabling the use of smaller actuators or Becker's exclusive Bleed to Pressure System (BPS™) feature.

Features

- Bleed to Pressure System™ can eliminate bleed gas emissions
- Retrofits to almost any pipeline valve
- High Pressure RPSR Actuator accepts high-pressure natural gas up to 500 psig (3447 kPa)
- Upright actuator design saves space and promotes longer actuator piston life
- Designed to be maintenance free
- Comes equipped with a high visibility scale that indicates valve position
- Crank-arm design actuators are specifically suited for control valve applications
- May be mounted in any installation orientation

Technical Specifications	
Actuator Type	Quarter turn (90° Rotation)
Mechanism	Crank-arm
Usage	Heavy-duty
Action	Single-acting (fail-open or fail-closed)
Applications	Throttling, On-Off, Surge Control
Maximum Gas Supply	50 psig (3447 kPa)
Bleed to Pressure System	Yes
Below Ground Design	Yes
Maximum Valve Size	16" bore (406 mm)
Minimum Valve Size	2" bore (50 mm)
Stop Adjustment	Internal
Torque Output	1100 - 130,000 + in. lbs.
Compatible Valves	FPCV-T0, QTCV-T1, QTCV-T2, QTCV-T3 and QTCV-T4



Becker RPSR Rotary Piston Spring Return Actuator Components

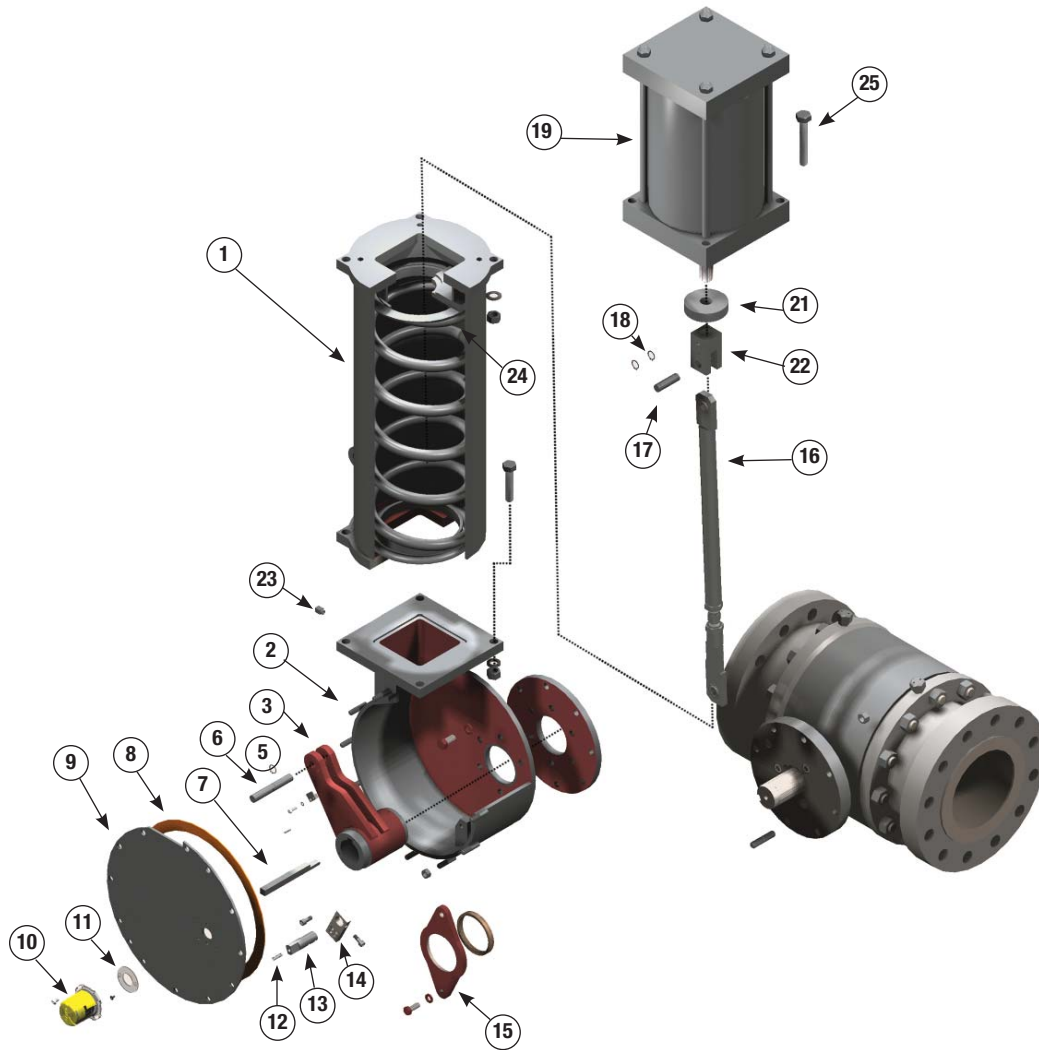

Figure 3 - RPSR Rotary Piston Spring Return Actuator Exploded View

Item	Quantity	Description	Material	Item	Quantity	Description	Material
1	1	Spring Cartridge	Carbon Steel	14	1	Mounting Bracket	Carbon Steel
2	1	Actuator Housing	Carbon Steel	15	1	Outboard Plate	Carbon Steel w/Duralon 15
3	1	Torque Arm	Carbon Steel	16	1	Adjustable Connecting Link	Carbon Steel w/SS Bearings
5	1	Pin Clamp	Carbon Steel	17	1	Rod Clevis Pin	Stress Proof Steel
6	1	Pin Clamp	Carbon Steel	18	3	Tru-arc Ring	Carbon Steel
7	1	Torque Arm Pin	Stress Proof Steel	19	1	Cylinder	Various**
8	1	Gasket	Rubber	21	1	Cylinder Rod Flange	Carbon Steel
9	1	Cover Plate	Carbon Steel	22	1	Rod Clevis	Carbon Steel
11	1	Spacer Ring	Aluminum	23	1	Housing Vent	Plastic
12	1	Spring	Alloy Steel	24	1	Cylinder Mtg. Nut	Carbon Steel
13	1	Extended Stem	Aluminum	25	1	Cylinder Mtg. Bolt	Carbon Steel

Becker RPSR Rotary Spring Return Actuator Cylinder Components

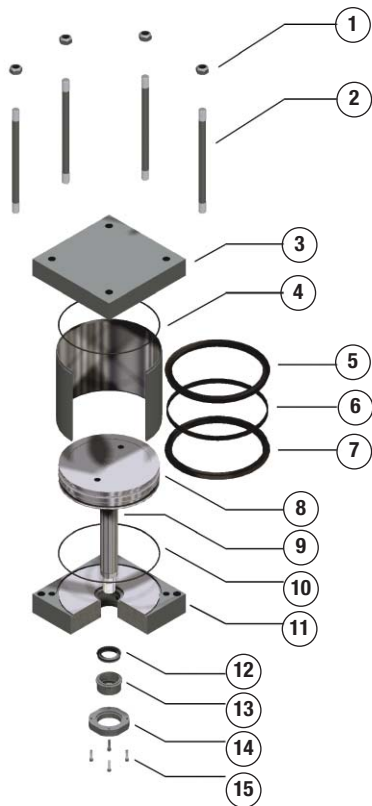

Figure 4 - RPSR Actuator Cylinder Exploded View

Item	Description	Material
1	Hex Nut	Steel
2	Cylinder Tie-Rod	High Strength Steel
3	Piston Head (top)	Steel
4	Tube Seal (top)	Buna-N O-Ring
5***	Piston U-Cup Seal (top)	Buna-N
6	Piston Wear Strip	Reinforced Teflon®*
7***	Piston U-Cup Seal (bottom)	Buna-N
8	Piston	Nodular Iron
9	Piston Rod	Hard Chrome Plate
10	Tube Seal (bottom)	Buna-N O-Ring
11	Piston Head (bottom)	Steel
12	Piston Rod Seal	Polyuerthane
13	Piston Rod Bearing	Duralon®**
14	Gland Plate	Steel
15	Gland Plate Screws (SHCS)	Alloy Steel
16	Piston Tube	Precision Honed Steel

Notes:

* Teflon is a registered trademark of Dupont Company

** Duralon is a registered trademark of Rexnord, Inc.

*** For low temperature design, alternate Buna-N (low temp) utilized for items 5 & 7. For high temperature design, alternate Buna-N (high temp) utilized for items 5 & 7

RPSR Actuators Standard Mounting Configurations

Figure 5.1

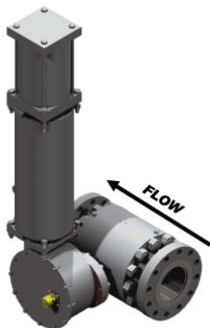

Mount #1 - Left Hand (Standard) with clean sweep feature

Actuator located on left hand side of valve when looking in direction of flow (actuator vertical/valve stem horizontal).

Figure 5.2



Mount #2 - Right Hand

Actuator located on right hand side of valve when looking in direction of flow (actuator vertical/valve stem horizontal).

Figure 5.3

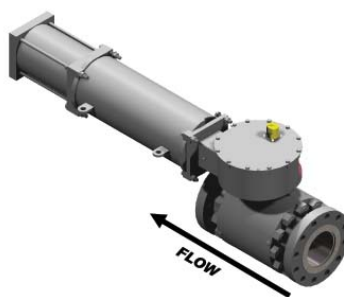

Mount #3 - Vertical Stem (Actuator Downstream)

Actuator located on downstream side of valve when looking in direction of flow (actuator horizontal/valve stem horizontal).

Figure 5.4

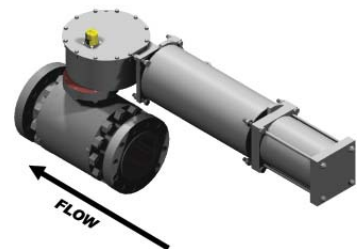

Mount #4 - Vertical Stem (Actuator Upstream)

Actuator located on up-stream side of valve when looking in direction of flow (actuator horizontal/valve stem horizontal).

RPSR Actuators are Specifically Suited for Fast-Acting Applications, such as Surge Control/Recycle Valves!



Bleed to Pressure System Can Eliminate Bleed Gas Emissions

Becker RPSR Actuators feature the unique ability to incorporate the Bleed to Pressure System™ Feature. Becker RPSR Actuators and control instrumentation can accept high pressure power gas and discharge “bleed gas” to lower pressure systems. Bleed to Pressure System™ eliminates all atmospheric emissions!

Maintenance Free

The RPSR Actuator is designed to be maintenance free, no regular lubrication is required for the piston cylinder or the actuator.

Vertical Advantage

Upright actuator promotes longer actuator piston seal life, saves space, and requires less maintenance than other actuators.

Non-Field Serviceable Spring Cartridge Ensures Safety

The RPSR spring cartridge features an all-welded design that is serviceable only via our manufacturing facility. The non-Field Serviceable design minimizes potential for injury by prohibiting field disassembly of the spring cartridge portion of the RPSR actuator.

Connecting Line with Stainless Steel Spherical Bearings Eliminates Side Load

Actuator Spring Designed for High Speed, High Frequency Operation

The RPSR Actuator spring is manufactured from heat-treated 6150H alloy steel for superb fatigue resistance and virtually infinite life. The RPSR spring is capable of providing long-life even under the most demanding applications.

Easy to Read Travel Indicator

All RPSR actuators come equipped with high visibility scale that indicates valve position.

Crank Arm Designed For Control Valves

Crank arm design actuators are specifically suited for control applications. The crank arm provides an increasing torque curve that develops high torque output where it counts. Additionally, the crank arm design minimizes friction and lost motion.

Below Ground Actuator Option Reduces Noise Attenuation up to 37 dBA

Becker RPSR Actuators are available with a unique below ground option that provides superior noise attenuation in regulator stations at minimal cost. Additionally, below ground stations also minimize ambient heat loss by maintaining piping systems below ground.

High Pressure Capability

The RPSR Actuator is specifically constructed to accept high pressure natural gas up to 500 psig (3448 kPa). Higher pressure power gas allows use of smaller actuators and implementation of Becker’s unique bleed to pressure system.

We can retrofit to almost any valve in your pipeline!

We can provide high quality actuators to mate to almost any quarter turn valve, regardless of manufacturer or age. We have years of experience successfully adapting our actuators to fit a multitude of valves.

U-Cup Piston Seals

U-cup Piston Seals are designed to provide superior sealing capabilities with minimal friction. This design allows accurate positioning of the control valve actuator with very slight pressure differential to the piston.

Custom Coatings Available

Standard preparation of Becker RPSR actuators includes sandblast per SP-10 and epoxy coating for above ground actuators and coal tar epoxy for below ground actuator portions. RPSR actuators are available with custom coatings to suit application needs.

Torque Arm Bearings

RPSR Actuators features two large Torque Arm Bearings to eliminate side load to control valve stem. Both inboard and outboard torque arm bearings are manufactured from non-metallic Duralon™ material to ensure maximum load bearing capacity.



Figure 6 - Cutaway view of RPSR Actuator and Cylinder.

Figure 7 - RPSR Actuators (Single Spring Cartridge)

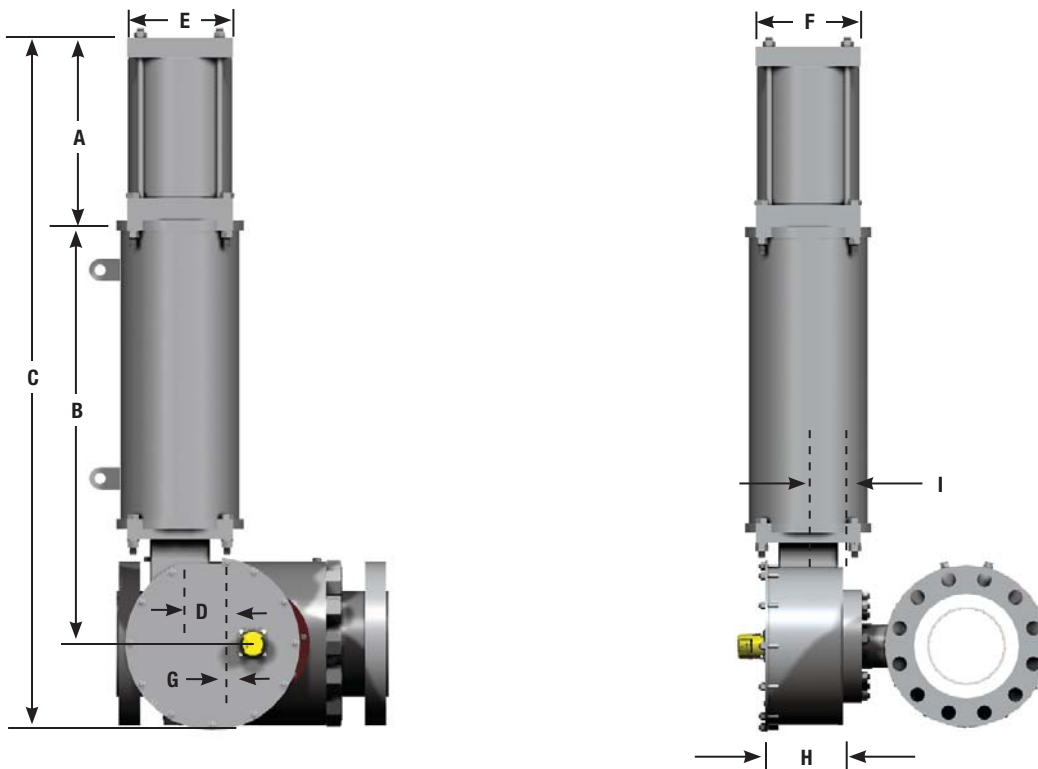

Table 3 - RPSR Actuators Dimensions (Single Spring Cartridge)

Model	Dimensions inches (mm)									Weight
	A	B	C	D	E	F	G	H	I	lbs (kg)
5D-SR-2	9.56 (243)	20.75 (527)	35.56 (903)	2.38 (60)	7.63 (194)	5.50 (140)	0.38 (10)	5.38 (137)	2.13 (54)	175 (79)
6F-SR-7	12.19 (310)	27.19 (691)	45.63 (1159)	3.63 (92)	8.63 (219)	6.50 (165)	1.38 (35)	7.00 (178)	2.75 (70)	375 (170)
6D-SR-2	10.50 (267)	20.25 (514)	35.69 (906)	2.38 (60)	8.63 (219)	6.50 (165)	0.38 (10)	5.38 (137)	2.13 (54)	200 (91)
6D-SR-7	10.19 (259)	22.69 (576)	38.13 (986)	2.38 (60)	8.63 (219)	6.50 (165)	0.38 (10)	7.00 (178)	2.13 (54)	315 (143)
8F-SR-7	11.69 (297)	34.75 (883)	46.44 (1180)	3.63 (92)	8.50 (216)	8.50 (216)	1.38 (35)	7.00 (178)	2.75 (70)	410 (186)
8F-SR-8	11.69 (297)	30.88 (784)	48.81 (1240)	3.63 (92)	8.50 (216)	8.50 (216)	1.38 (35)	7.00 (178)	2.75 (70)	423 (192)
10F-SR-33	13.06 (332)	32.75 (832)	52.06 (1322)	3.63 (92)	10.63 (270)	10.63 (270)	1.38 (35)	7.00 (178)	2.75 (70)	565 (256)
8H-SR-33	13.69 (348)	36.25 (921)	57.06 (1449)	4.75 (121)	10.63 (270)	8.50 (216)	1.50 (38)	7.63 (194)	2.75 (70)	525 (238)
10H-SR-33	15.06 (383)	36.25 (921)	58.44 (1484)	4.75 (121)	10.63 (270)	10.63 (270)	1.50 (38)	7.00 (178)	2.75 (70)	610 (277)
10H-SR-39	15.06 (383)	37.13 (943)	58.44 (1484)	4.75 (121)	10.63 (270)	10.63 (270)	1.50 (38)	10.75 (273)	2.75 (70)	795 (361)

Notes: 1. Dimensions "B" & "C" will change for below ground units according to depth of burial.
2. For surge control design RPSR Actuator dimensions, refer to Becker Surge Control Valves Brochure

Figure 8 - RPSR Actuators (Single Spring Cartridge)

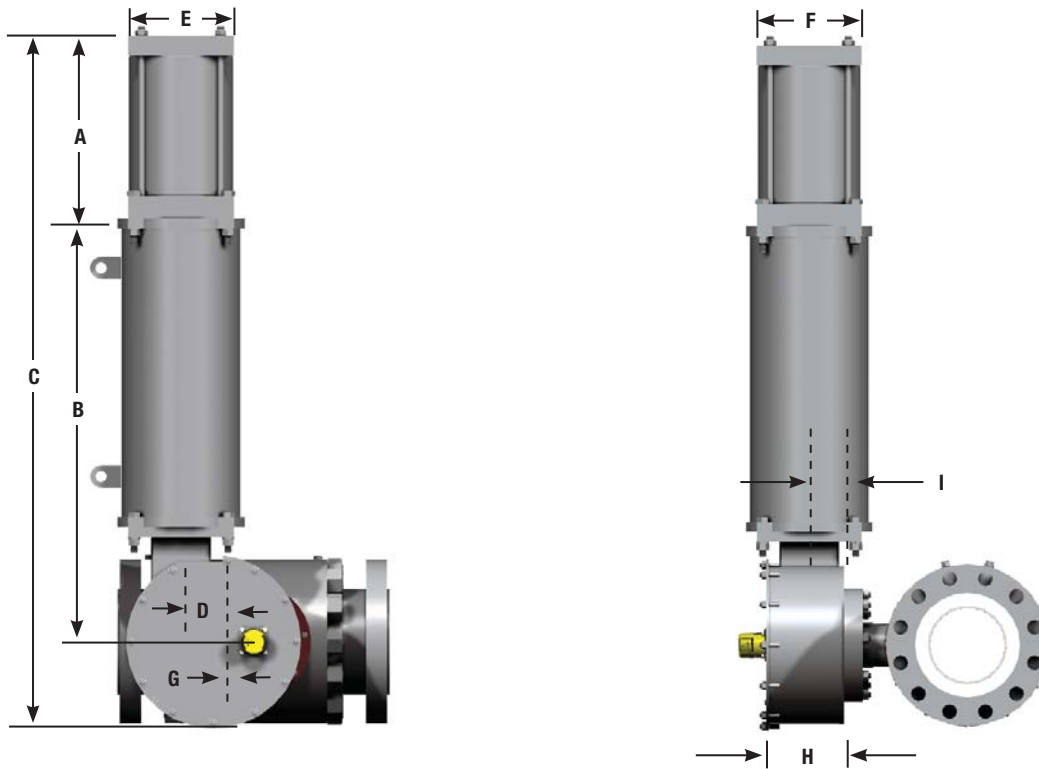

Table 3 - RPSR Actuators Dimensions (Single Spring Cartridge)

Model	Dimensions inches (mm)									Weight
	A	B	C	D	E	F	G	H	I	lbs (kg)
10L-SR-33	19.06 (484)	40.25 (1022)	64.00 (1626)	7.25 (184)	10.63 (270)	10.63 (270)	4.00 (102)	8.50 (216)	3.50 (89)	765 (347)
10L-DR-39	19.06 (484)	42.63 (1083)	70.44 (1789)	7.25 (184)	10.63 (270)	10.63 (270)	4.00 (102)	8.50 (216)	3.50 (89)	940 (426)
10L-DR-41	19.06 (484)	43.63 (1108)	71.44 (1815)	7.25 (184)	10.63 (270)	10.63 (270)	4.00 (102)	8.50 (216)	3.50 (89)	1000 (454)
12I-SR-39	19.06 (484)	42.63 (1083)	69.94 (1776)	7.25 (184)	12.75 (324)	12.75 (324)	4.00 (102)	8.63 (219)	3.63 (92)	1050 (476)
12L-SR-41	19.56 (497)	42.88 (1089)	71.19 (1808)	7.25 (184)	12.75 (324)	12.75 (324)	4.00 (102)	8.63 (219)	3.63 (92)	1100 (499)

Table 4 - RPSR Actuators Dimensions (Dual Spring Cartridge)

Model	Dimensions inches (mm)									Weight
	A	B	C	D	E	F	G	H	I	lbs (kg)
12L-SR-41/33	19.56 (497)	42.88 (1089)	71.19 (1808)	7.25 (184)	12.75 (324)	12.75 (324)	4.00 (102)	8.63 (219)	3.63 (92)	1158 (525)
12L-SR-39/7	19.56 (497)	41.88 (1064)	70.19 (1783)	7.25 (184)	12.75 (324)	12.75 (324)	4.00 (102)	8.63 (219)	3.63 (92)	1140 (517)
14L-SR-41/33	20.94 (532)	42.88 (1089)	72.56 (1843)	7.25 (184)	14.75 (375)	14.75 (375)	4.00 (102)	8.63 (219)	3.63 (92)	1353 (614)
14L-SR-39/7	19.06 (484)	31.13 (791)	70.44 (1789)	7.25 (184)	14.75 (375)	14.75 (375)	4.00 (102)	8.50 (216)	3.63 (92)	1335 (606)

Notes:

1. Dimensions "B" & "C" will change for below ground units according to depth of burial.
2. For surge control design RPSR Actuator dimensions, refer to Becker Surge Control Valves Brochure

Figure 8 - RPSR Actuator (Two Spring Cartridges)

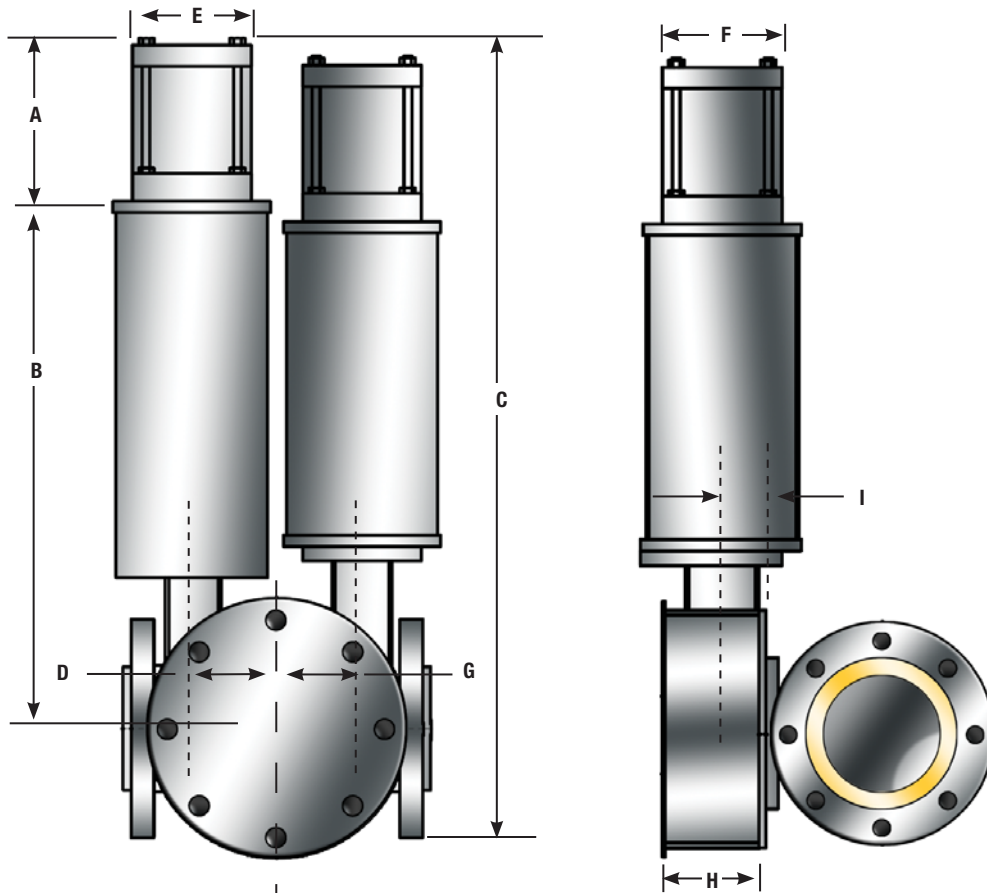

Table 5 - RPSR Actuators Dimensions (Two Spring Cartridge)

Model	Dimensions inches (mm)									Weight
	A	B	C	D	E	F	G	H	I	lbs (kg)
D10L-SR-39/39/7	19.06 (484)	47.13 (1197)	79.19 (2011)	7.25 (184)	10.63 (270)	10.63 (270)	7.25 (184)	8.50 (216)	3.63 (92)	1815 (823)
D10L-SR-39/41	19.06 (484)	47.13 (1197)	79.19 (2011)	7.25 (184)	10.63 (270)	10.63 (270)	7.25 (184)	8.50 (216)	3.63 (92)	1785 (810)
D10L-SR-39/7/41	19.06 (484)	47.13 (1197)	80.19 (2037)	7.25 (184)	10.63 (270)	10.63 (270)	7.25 (184)	8.50 (216)	3.63 (92)	1875 (850)
12L/10L-SR-39/7/39	19.56 (497)	47.13 (1197)	79.19 (2011)	7.25 (184)	10.63 (270)	10.63 (270)	7.25 (184)	8.63 (219)	3.63 (92)	1925 (873)
12L/10L-SR-39/7/41	19.56 (497)	47.13 (1197)	79.19 (2011)	7.25 (184)	10.63 (270)	12.75 (324)	7.25 (184)	8.63 (219)	3.63 (92)	1985 (900)
D12L-SR-D39	19.56 (497)	47.13 (1197)	79.69 (2024)	7.25 (184)	10.63 (270)	12.75 (324)	7.25 (184)	8.63 (219)	3.63 (92)	1935 (878)
D12L-SR-39/39/7	19.56 (497)	47.13 (1197)	79.69 (2024)	7.25 (184)	10.63 (270)	12.75 (324)	7.25 (184)	8.63 (219)	3.63 (92)	2035 (923)
D12L-SR-39/41/33	19.56 (497)	47.13 (1197)	81.69 (2075)	7.25 (184)	12.75 (324)	12.75 (324)	7.25 (184)	8.63 (219)	3.63 (92)	2053 (931)
12N/12M-SR-D41/8	21.53 (547)	51.13 (1299)	86.66 (2201)	7.88 (200)	10.63 (270)	12.75 (324)	8.50 (216)	10.75 (273)	3.63 (92)	2306 (1046)
12N/12M-SR-41/43/33	21.53 (547)	51.13 (1299)	86.66 (2201)	7.88 (200)	12.75 (324)	12.75 (324)	8.50 (216)	10.75 (273)	3.63 (92)	2260 (1025)
14N/12M-SR-D41/8	22.79 (579)	21.13 (537)	57.92 (1471)	7.88 (200)	14.75 (375)	12.75 (324)	8.50 (216)	10.75 (273)	3.63 (92)	2490 (1129)

Notes: 1. Dimensions "B" & "C" will change for below ground units according to depth of burial.
2. For surge control design RPSR Actuator dimensions, refer to Becker Surge Control Valves Brochure

Table 6 - Becker RPSR Spring Return Rotary Piston Actuator Selection Table for Standard Control Service

Temperature = -20° F (-6.6°C) 80 psig (5.5 barg) Power Gas

T-Ball Valve Size	500 psi (34 bar) = ΔP		1000 psi (69 bar) = ΔP		1500 psi (104bar) = ΔP	
	Fail Closed	Fail Open	Fail Closed	Fail Open	Fail Closed	Fail Open
2" (50 mm)	6D-SR-2	6D-SR-2	6D-SR-2	6D-SR-2	8D-SR-7	6D-SR-2
3" (80 mm)	8F-SR-7	8F-SR-7	8F-SR-7	8F-SR-7	8F-SR-7	8F-SR-7
4" (100 mm)	10F-SR-8	8F-SR-7	10F-SR-8	10F-SR-8	10F-SR-8	10F-SR-8
6" (150 mm)	10H-SR-33	10H-SR-33	10H-SR-33	10H-SR-33	12L-SR-39	10H-SR-33
8" (200 mm)	12L-SR-39	12L-SR-39	12L-SR-39	12L-SR-39	14L-SR-41/8	12L-SR-39
10" (250 mm)	14L-SR-41	12L-SR-39	D12L-SR-D39	14L-SR-41	12M/12N-SR-D41	14L-SR-41
12" (300 mm)	D12L-SR-41/39	10L/12L-SR-D39	12M/12N-SR-D41	D12L-SR-D39	14M/14N-SR-D41/8	D12L-SR-D39

Temperature = -20° F (-6.6°C) 100 psig (6.9 barg) Power Gas

T-Ball Valve Size	500 psi (34 bar) = ΔP		1000 psi (69 bar) = ΔP		1500 psi (104 bar) = ΔP	
	Fail Closed	Fail Open	Fail Closed	Fail Open	Fail Closed	Fail Open
2" (50 mm)	5D-SR-2	5D-SR-2	5D-SR-2	5D-SR-2	6F-SR-7	6F-SR-7
3" (80 mm)	6F-SR-7	6F-SR-7	8F-SR-7	8F-SR-7	8F-SR-8	8F-SR-7
4" (100 mm)	8F-SR-8	8F-SR-8	8F-SR-8	8F-SR-8	8F-SR-8	8F-SR-8
6" (150 mm)	10F-SR-33	10F-SR-33	10H-SR-33	10H-SR-33	10H-SR-39	10H-SR-33
8" (200 mm)	10L-SR-39	10L-SR-39	10L-SR-39	10L-SR-39	14L-SR-41/33	12L-SR-41
10" (250 mm)	12L-SR-41	12L-SR-41	14L-SR-41/33	12L-SR-39	14L-SR-41/33	12L-SR-41
12" (300 mm)	14L-SR-41/33	14L-SR-41/8	D10L-SR-39/39/7	14L-SR-41/8	12N/12M-SR-41/41/33	D12L-SR-D39

Temperature = -20° F (-6.6°C) 125 psig (8.6 barg) Power Gas

T-Ball Valve Size	500 psi (34 bar) = ΔP		1000 psi (69 bar) = ΔP		1500 psi (104 bar) = ΔP	
	Fail Closed	Fail Open	Fail Closed	Fail Open	Fail Closed	Fail Open
2" (50 mm)	5D-SR-2	5D-SR-2	5D-SR-2	5D-SR-2	6D-SR-7	6D-SR-7
3" (80 mm)	6F-SR-7	6F-SR-7	6F-SR-7	6F-SR-7	8F-SR-8	6F-SR-7
4" (100 mm)	8F-SR-8	8F-SR-8	8F-SR-8	8F-SR-8	8F-SR-8	8F-SR-8
6" (150 mm)	8H-SR-33	8H-SR-33	8H-SR-33	8H-SR-33	10F-SR-39	10F-SR-39
8" (200 mm)	10L-SR-39	10L-SR-39	10L-SR-39	10L-SR-39	12L-SR-41/33	10L-SR-41
10" (250 mm)	10L-SR-41	10L-SR-41	12L-SR-41/33	12L-SR-41	12L-SR-41/33	12L-SR-41
12" (300 mm)	12L-SR-41/33	12L-SR-39/7	D10L-SR-39/39/7	12L-SR-41/33	D12L-SR39/41/33	14L-SR-41/33

1. Customers should Contact Dresser for valve sizes over 12" bore
2. For Power Gas Pressures greater than 125 psig (862 kPa) or less than 100 psig (689 kPa) contact Dresser
3. For higher ΔP Applications contact Dresser
4. Power Gas = P_{supply} - P_{discharge} for applications that utilize Bleed to Pressure System™ feature
5. Refer to Surge Control brochure for Surge Actuators selection table

Becker RPSR Actuators are Available with Optional “Surge Design” for Quick Stroking Applications where Speed of Response is Critical.

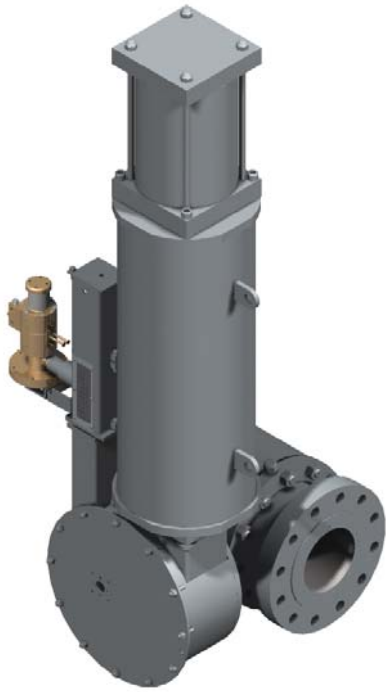

Figure 10 - Becker Surge Control Valve
The Becker Surge Control Valve incorporates the Surge Design RPSR Actuator to provide protection on centrifugal natural gas pipeline compressors. The Surge Control Valve can provide stroking times less than 750 mSec.

The RPSR Surge Design features components necessary to handle the rigors of high speed control valve applications:

- Stroke times 750 mSec or less
- Pneumatic cushion for protection of actuator piston at end of travel
- Heavy duty pneumatic piston to accommodate fast, frequent stroking with superior reliability
- QEV Series Quick Exhaust Valves for fast dump of pneumatic loading

Note: When RPSR Surge Design is incorporated, caution must be exercised to ensure that the mated control valve can accommodate the impulse loading without damage to the control valve stem and trim components. For implementation of Becker T-Balls (Models FPCV-T0, QTCV-T1, QTCV-T2, and QTCV-T4) Surge Design T-Ball control valves must be utilized to accommodate quick stroking speeds. Becker Surge Design T-Balls are designated as follows: FPCV-T0S, QTCV-T1S, QTCV-T2S, and QTCV-T4S. Failure to utilize proper control valves and actuators for fast-acting control valve applications could result in damage to the equipment and/or the operator. For complete guidelines for application of Surge Design RPSR Actuators and Surge Design T-Ball control valves, contact Becker.

Typical Applications for “Surge Design” RPSR Actuators:

- Surge Control Valves
- Slam Shut Valves
- Fast-Acting Monitor Regulators
- Other Quick Stroking Control Valve Applications



Figure 11 - Surge Control Valves Centrifugal Natural Gas Compressors (Natural Gas Transmission Industry)
Becker Surge Control Valves provide increased protection for Centrifugal Natural Gas Compressors. The Surge Control Valve will open rapidly upon potential surge to protect the centrifugal compressor mechanism. Becker Surge Control Valves are well accepted by many Natural Gas Transmission companies and Natural Gas Compressor manufacturers throughout the industry. For additional information see Becker’s Surge Control Valve Brochure (SCV)..

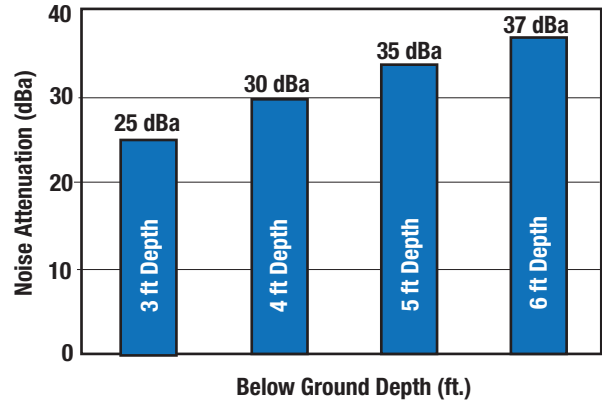

Figure 12 - Slam Shut and Fast-Acting Monitor Regulators Natural Gas Fired Power Plants (Power Generation Industry)
Fast-Acting Monitor Regulators and Slam Shut Valves provide the ultimate protection to Natural Gas Fired Turbines from overpressure occurrence. These monitor regulators and slam shut valves utilize Surge Design RPSR Actuators to ensure quick stroking and minimize potential of damage to downstream pipe and equipment in the event of potential over-pressurization. Slam Shut shut valves and fast stroking monitor regulators are standard to most Becker pressure regulator stations that feed power plants due to their reliability and purpose built design.

The Becker Below Ground Ball Valve Regulator option is unique to Becker and provides a multitude of benefits by direct burial of the control valve. The valve actuator, lubrication lines, and drain lines are extended above ground while the ball valve remains below ground. The primary advantage of Becker below ground regulators is inexpensive noise attenuation in excess of 25 dBA.

- More than 25 dBA noise attenuation
- Less ambient heat loss
- May use smaller adjacent piping diameter
- Smaller station footprint
- Most economical noise attenuation
- May eliminate need for buildings/enclosures by utilizing the fiberglass cabinet

Below Ground Regulator Option providing additional noise attenuation



Noise Attenuation as Factor of Below Ground Depth
Typical below ground depths range from 3 feet to 6 feet burial.

The below ground depth is measured from centerline of pipe to ground. Below ground usually provides from 25 dBA to 37 dBA noise attenuation.



Figure 13 - Installation of Becker Below Ground Regulators (Prior to Backfill)

A large natural gas transmission/distribution company installed Becker Below Ground Ball Valve Regulators to achieve maximum noise attenuation, minimal maintenance, and optimum cost effectiveness. The Below ground regulator can provide up to 37 dBA additional noise attenuation with minimal additional cost. Model QTCV-T2 Quiet Trim Control Valves were added to provide additional 15 dBA noise attenuation, bringing total overall noise attenuation up to 50 dBA. The Below Ground Ball Valve regulators are shown during installation, prior to backfill of the regulator station.

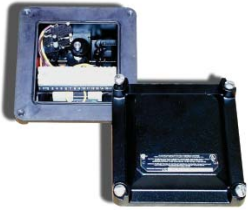

Figure 14 - Installation of Becker Below Ground Regulators (After Backfill)

The above installation photo demonstrates the “clean” design of the regulator station. After backfill of the station, only the topworks portion of the RPSR actuators extend above ground. The piping system remains below ground, minimizing noise and ambient heat loss. Additionally, technicians find the station design to be easily accessible due to absence of above ground piping and fittings.

Accessories

Becker Control Valve Actuators provide reliability and accuracy for all of your control valve applications



Limit Switches

Limit switches provide an indication of valve status and are commonly utilized on both on-off and control valves. A limit switch assembly will close a contact at both the full-open and at the full-closed position of valve travel. The switches provide a remote indication to gas control, RTU or a flow computer as to the status of a valve. Limit switch assemblies are available with a variety of configurations.

Housing	NEMA 4, 4X, 7, Class I, Groups C & D, Division 1 & 2	SPDT	Single Pole, Double Throw
Switches	2 or 4	DPDT	Double Pole, Double Throw
Option	2 or 4 Hermetically Seales Switches		up to 125 V D.C. at .5 amps up to 250 V A.C. at 15 amps

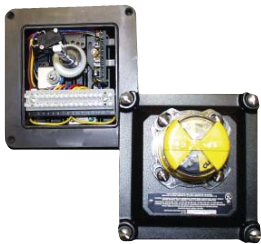

Position Transmitter

The Valve Position Feedback assembly provides a quantitative indication of the exact position of a control valve. The Valve Position Feedback assembly provides 4-20 mA analog remote position feedback proportional to the control valve position. The feedback signal may be utilized as an integral portion of the control loop or merely as an additional feedback signal to gas control for monitoring valve status. Valve Position Feedback is typically used on flow control valves is:

Transmitter	4-20 mA Output	SPDT	Single Pole, Double Throw
Housing	NEMA 4, 4X, 7, Class I, Groups C & D, Division 1 & 2	DPDT	Double Pole, Double Throw
Switches	2 or 4		up to 125 V D.C. at .5 amps up to 250 V A.C. at 15 amps
Option	2 or 4 Hermetically Seales Switches		



Hydraulic Operator Override

The Hydraulic pump override is utilized for manual operation of large control valves when pneumatic power is not available. The Hydraulic pump override utilizes a hydraulic pump and reservoir to develop necessary torque to close/open the control valve. Note that Hydraulic pump overrides are typically utilized on ball control valves larger than 16" bore.



Gear Operator Override

The Manual Handwheel is utilized for manual operation of small/medium sized control valves when pneumatic power is not available. The handwheel utilizes a system of gear multipliers to develop necessary torque to close/ open the control valve. Note that Manual Handwheels are limited ball type control valves 16" bore and smaller.

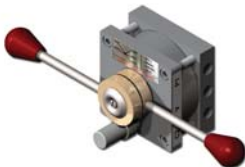

MCV

The MCV Series Manual Control Valve provides manual operation of pneumatic valve actuators. The MCV is the ideal device for maintenance and manual operation of control valves. The MCV allows the user to override the primary control instrumentation and position the control valve actuator in any position. The unique safety button feature of the MCV prevents unintentional operation. An optional locking feature is available for additional security.

Maximum Allowable Operation Pressure

Model MCV-3	Up to 150 psig (1034 kPa)	All Ports	1/4" FNPT
Model MCV-3M	150 (1034 kPa) to 250 psig (1724 kPa)	Weight	10 lbs (4.5 Kg)
Model MCV-3H	250 (1723 kPa) to 500 psig (3447 kPa)		

Let Becker Help Select the Perfect Rotary Control Valve Actuator!

Table 8 - Selection table for Becker Control Valves and Actuators

	RPDA (Small Models)	RPDA (Large Models)	SYDA (Small Models)	SYDA (Large Models)	RPSR	SYSR	LPDA (Small Models)	LPDA (Large Models)	LPSR	LD
Actuator Instrumentation										
VRP-CH-Pilot	•	•	•	•			•	•		
VRP-B-CH Pilot	•	•								
VRP-SB-CH-Pilot					•	•			•	•
VRP-SB-PID Pilot					•	•			•	•
HPP-4 Positioner	•	•	•	•			•	•		
HPP-5 Positioner	•	•					•			
HPP-SB Positioner					•	•			•	•
DNGP Positioner	•	•	•	•	•	•	•	•	•	•
VRP-SB-GAP	•	•	•	•	•	•	•	•	•	•
Compatible Valves										
FPCV-T0	•	•	•	•	•	•				
QTCV-T1	•	•	•	•	•	•				
QTCV-T2	•	•	•	•	•	•				
QTCV-T4	•	•	•	•	•	•				
Globe Series							•		•	•
Actuator Options										
Bleed to Pressure System BPS™	•	•	•	•	•	•	•	•	•	•
AB Series Atmospheric Bleed Control	•	•	•	•	•	•	•	•	•	•
NBV Series No-Bleed Valve	•	•					•	•		
DPS-2 Series Non-Bleed Sensor	•	•					•	•		
PS-2 Series Non-Bleed Sensor	•						•			
SP Series Setpoint Pump	•	•	•	•	•					
RSM Series Remote Setpoint Module	•	•	•	•	•					
Panel Mounting	•	•	•	•	•					•
Stainless Steel Option	•	•	•	•	•	•	•	•		
VB Series Volume Booster	•	•	•	•	•	•	•	•		
QEV Series Quick Exhaust Valve				•				•		
I/P Transducer						•	•	•		
SLV Series Signal Lock Valve						•	•	•		

1. RPSR, SYDA, and LPDA Small Models are defined as actuator size <2000 in³ (0.333m³).
2. RPSR, SYDA, and LPDA Large Models are defined as actuator size >2000 in³ (0.333m³).
3. LD Series Actuators are limited to Becker Series Globe Valves
4. BPS™ is limited to discharge pressure systems below 300 psig (2068 kPa). Consult Becker for application assistance.

***CAUTION:** This information is intended as a guideline for application of Becker Control Valve products. Becker strongly recommends consulting Becker Engineering prior to application of any product.

Becker has a wide variety of control valve actuators with a variety of features that ensure the optimum solution for your application needs. Refer to the Figures in the Table 8 to assist you in selecting the proper control valve actuator and accessories.



Figure 15 - Becker RPSR Actuated Control Valves in Power Plant

A Becker RPSR actuated control valve is used to provide primary pressure regulation and overpressure protection (monitor regulators) on a feed to a gas-fired power plant. The RPSR shown here are equipped with Becker Model HPP-SB High Pressure Positioners to provide maximum speed of response combined with optimum accuracy.



Figure 16 - Becker RPSR Actuators are ideal for Surge Control/Recycle Valves

Becker RPSR Actuators are ideal for use as Surge Control/Recycle Valves installed on centrifugal gas pipeline compressors. The RPSR may be equipped with a pneumatic cushion system to enable quick stroking of control valves from closed to open position in 750 mSec or less. The RPSR may also be configured for other high speed applications such as high speed slam shut valves.

Additional Resources are available on our website. Sales literature, sizing software, and technical manuals are available for download at www.dresser.com/becker



About Dresser Products

Dresser brand products are highly engineered, technically superior and are designed to help global customers meet and exceed requirements for mission critical energy applications.

About Dresser, Inc.

Dresser, Inc. is a leader in providing highly engineered infrastructure products for the global energy industry. The company has leading positions in a broad portfolio of products, including valves, actuators, meters, switches, regulators, piping products, natural gas-fueled engines, retail fuel dispensers and associated retail point-of-sale systems, and air and gas handling equipment. Leading brand names within the Dresser portfolio include Dresser Wayne® retail fueling systems, Waukesha® natural gas-fired engines, Masoneilan® control valves, Consolidated® pressure relief valves, and Roots® blowers. It has manufacturing and customer service facilities located strategically worldwide and a sales presence in more than 100 countries.

Dresser, Inc.

1550 Greenleaf Avenue
Elk Grove Village, Illinois 60007 USA
Ph: 847.437.5940 Fax: 847.437.2549
Toll Free Phone: 800.323.8844
Email: becker@dresser.com



www.dresser.com/becker