

Electric Actuator Smart Controller

Microprocessor Based Analog Positioner SCC10-115/230A, SCC10-24VAC

Quick Setup Instructions

Note 1: *The following instructions assume that the EASC DC board is installed in the actuator and all safety, installation and startup instructions outlined in the appropriate RCS and ANDCO installation and instruction manuals have been carried out. Be certain the actuator is in proper operating condition before attempting to calibrate the EASC DC board. Except for **Step 2.d. Positioning the potentiometer shaft** and **Step 2.e. Calibrating the controller**, the actuator will not move during setup.*

Note 2: *The Quick Setup instructions are suitable for:*

- *Input signal requirements of 4-20 mAdc, 1-5 Vdc, 0-10 Vdc or 2-10 Vdc*
- *Output signal requirements of 4-20 mAdc, 1-5 Vdc, 0-10 Vdc or 2-10 Vdc*
- *Loss of input signal: actuator does not move, fails in last place. For a setting of zero input signal the system fails to minimum signal position.*

For all other options, refer to sections 4 - 7 of this manual.

Note 3: *The terms “clockwise” and “counterclockwise” refer to the direction of rotation of the actuator output shaft, for rotary actuators, as viewed from the top of the actuator. For linear actuators, the term “extend”, rod moving away from the body of the actuator, and “retract”, rod moving into the body of the actuator, refer to the direction of movement of the extension rod. The EASC DC is always wired as shown in **Figure 1**. Refer to **Figure 1** for status lamp descriptions. Output rotation, for rotary actuators, or extension rod direction of movement, for linear actuators, is changed using **Step 2.c**.*

Key Functions

There are four keys used to select the system menus. The table below describes each key:

←	Go BACK one menu level and do not save value
↑	Move UP through menus or increase a value
↓	Move DOWN through menus or decrease value
↵	SELECT a menu item or save value

When working within the menus it is not necessary to return to the top level between setting parameters. The parameter value is saved to non-volatile memory when the **SELECT** key is pressed.

2. Quick Setup Instructions

a. Setting the analog input type:

1. Use the ↑ or ↓ keys until **in** is displayed, then press the **SELECT** key.
2. Press the ↑ or ↓ key until the type of input signal required, **1-5 Vdc**, **0-10 Vdc**, **2-10 Vdc**, **4-20 mAdc** is displayed.
3. Press the **SELECT** key to save the selection.

b. Setting the analog output type:

1. Use the ↑ or ↓ keys until **oUt** is displayed, then press the **SELECT** key.
2. Press the ↑ or ↓ key until the type of output signal required, **1-5 Vdc**, **0-10 Vdc**, **2-10 Vdc**, **4-20 mAdc** is displayed.
3. Press the **SELECT** key to save the selection.

c. Selecting output shaft rotation:

1. Press the \uparrow or \downarrow key until **rotn** is displayed, then press the **SELECT** key.
2. Press the \uparrow or \downarrow to select the direction of travel required to move the actuator towards the maximum signal position, **CC-r** (counterclockwise for rotary actuators or retract for linear actuators) or **C-E** (clockwise for rotary actuators or extend for linear actuators)
3. Press the **SELECT** key to save the selection.

d. Positioning the potentiometer shaft:

1. Press the \uparrow or \downarrow key until **Pot** is displayed, then press the **SELECT** key.
2. The display will change to show the actual potentiometer value in internal divisions (0-1023) and the \uparrow or \downarrow keys will now operate the actuator motor.
3. Run the actuator to approximately 50% of travel. Loosen the set screws retaining the potentiometer shaft. Rotate the shaft until the display reads approximately **510** divisions (50% of potentiometer span). Re-tighten the set-screws.
4. To verify the potentiometer and limit switch settings, press the \uparrow key to move the actuator electrically. The value displayed on the LED array should increase towards the maximum of 1023 divisions. When the limit switch stops the actuator, check that the switch setting is correct for the required travel. The displayed value will typically be 975 divisions, but must not exceed 1000 divisions.
5. Now press the \downarrow key to move the actuator in the opposite direction of travel. The value displayed should decrease in value towards the minimum value of zero. The displayed value will typically be 50 divisions, but must not be less than 20 divisions. The difference between the end of travel values must be at least 500 divisions.
6. Press the **SELECT** key to exit potentiometer setup.

e. Calibrating the controller:

1. Press the \uparrow or \downarrow key until **Cal** is displayed, then press the **SELECT** key.
2. Press the \uparrow or \downarrow key until **YES** is displayed, then press the **SELECT** key.
3. The automatic calibration sequence will now begin.
4. To stop a calibration in progress, press the \leftarrow key. The calibration will be aborted and the previous calibration restored.

The display will indicate the calibration steps, **C 1** through **C 11**, being performed. Should the calibration sequence fail, the display will indicate **CF X**, where **X** is the number of the calibration step that failed. See **Section 9. The Automatic Calibration System** for a description of the calibration steps. No calibration values are saved unless the calibration sequence completes normally. When calibration is complete, the display will again show **Cal**.

f. Exiting setup mode:

1. Press the \leftarrow key until the display shows the actual actuator position and the actuator begins to follow the input command signal.

Reloading the Factory Default Settings

The controller can restore all of the operating parameters to known values. The parameters should be restored under the following conditions:

1. The controller is operating erratically or positioning inaccurately;
2. The standard or advanced menus have been modified with unpredictable results;
3. The controller has been re-installed in a different actuator.

There are four available Factory Default setups. Each of the setups is accessed using one of the four keyboard keys as described in the table on the next page:

Key	Analog In/Out	Calibrate Delay Seconds
↗	1 - 5 Vdc	5
↓	4 – 20 mA dc	5
↑	0 – 10 Vdc	5
↖	4 – 20 mA dc	20

To reload the Factory Default Settings:

1. Disconnect the power source from the actuator.
2. Press and hold the desired key.
3. Restore the power to the actuator.
4. The display will read: **Fact**, then **done**.
5. Release the key.

The controller will require configuration and calibration after the reload operation is complete. See **Section 2. Quick Setup Instructions** for details.

Figure 1 - Connection Details

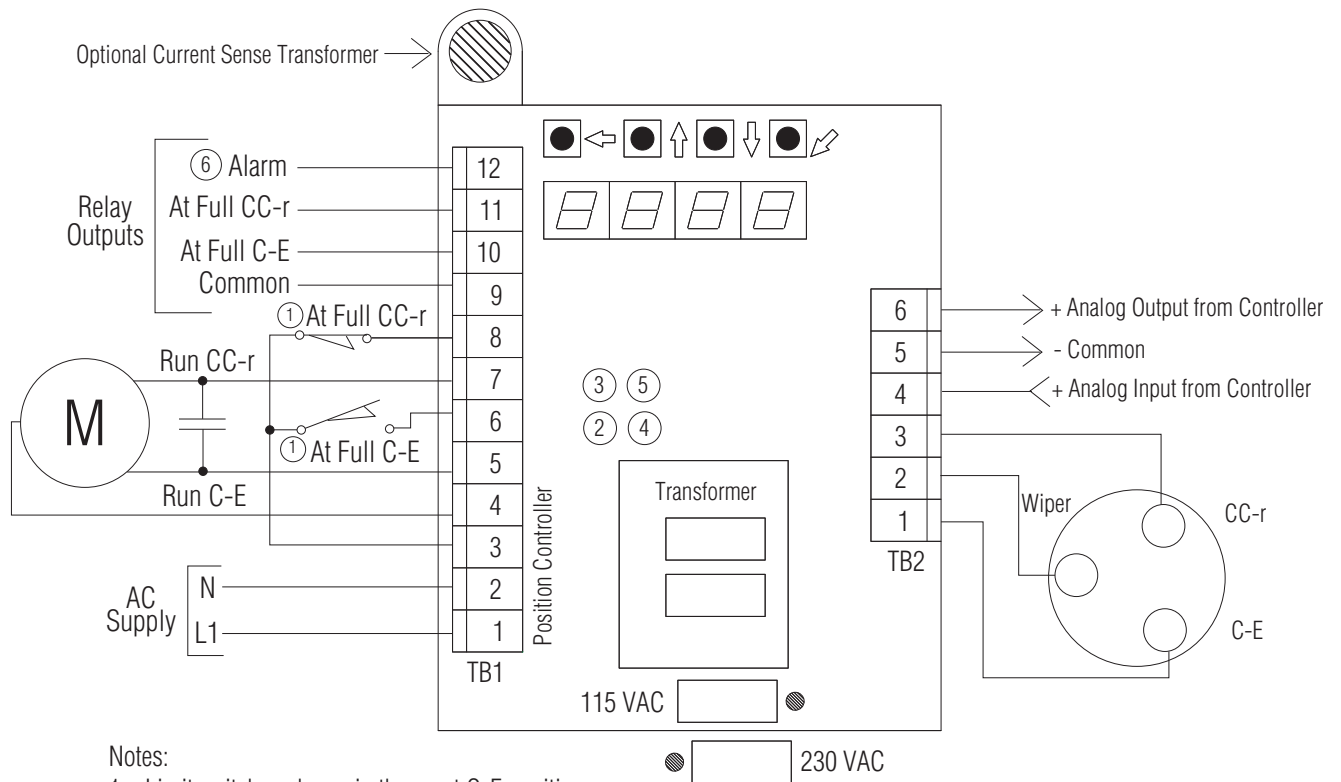

Notes:

1. Limit switches shown in the most C-E position
2. Green lamp off indicates potentiometer at full C-E
3. Green lamp off indicates potentiometer at full CC-r
4. Red lamp on indicates motor running in C-E direction
5. Red lamp on indicates motor running in CC-r direction
6. Alarm output will be open when power off, if in fault or when display in menu mode

Setting Nonstandard Input / Output Ranges

To select a nonstandard input/output range you will require a process loop calibrator or alternately a multimeter and an adjustable process signal source. Connect the process calibrator or multimeter to the analog input and output terminals. See **Figure 1** for connection details. The actuator will not move during this procedure.

a. Setting a nonstandard analog input:

1. Select the voltage or current input range that most closely matches your nonstandard configuration using **Step 2.a** of the **Setup Instructions**.
2. Use the \uparrow or \downarrow keys until **io** is displayed, then press the **SELECT** key.
3. Set the process calibrator to the lowest input value.
4. Use the \uparrow or \downarrow keys until **ioFt** is displayed, then press the **SELECT** key.
5. Use the \uparrow or \downarrow keys to set the controller display to 0.
6. Press the **SELECT** key to save the selection.
7. Set the process calibrator to highest input value.
8. Use the \uparrow or \downarrow keys until **iSPn** is displayed, then press the **SELECT** key.
9. Use the \uparrow or \downarrow keys to set the controller display to 100, or to full scale if the full scale value has been modified from 100.
10. Press the **SELECT** key to save the selection.
11. Press the \leftrightarrow key until the display shows actual actuator position in increments of 0-100% and the actuator begins to follow the input command signal.

b. Setting a nonstandard analog output:

1. Select the voltage or current output range that most closely matches your nonstandard configuration using **Step 2.b** of the **Setup Instructions**.
2. Use the \uparrow or \downarrow keys until **io** is displayed, then press the **SELECT** key.
3. Use the \uparrow or \downarrow keys until **ooFt** is displayed, then press the **SELECT** key.
4. Use the \uparrow or \downarrow keys to set the output signal lowest value as displayed on the process calibrator or multi-meter. The controller will automatically set the output to the lowest value during this step. The display indicates the value of the output d-a converter from 0 – 1023.
5. Press the **SELECT** key to save the selection.
6. Use the \uparrow or \downarrow keys until **oSPn** is displayed, then press the **SELECT** key.
7. Use the \uparrow or \downarrow keys to set the output signal highest value as displayed on the process calibrator or multi-meter. The controller will automatically set the output to the highest value during this step. The display indicates the value of the output d-a converter from 0 – 1023.
8. Press the **SELECT** key to save the selection.
9. Press the \leftrightarrow key until the display shows actual actuator position in increments of 0-100% and the actuator begins to follow the input command signal.

5. Selecting an Alternate Fail Position on Loss of Command Signal

The controller can sense the loss of the analog input signal for configurations that have an input signal at least 2% of full scale above zero input. Two settings are available, loss of signal threshold and position on loss of signal. The EASC offers four failure modes to control the movement of the actuator in the event of a command signal loss:

- Fail in last position: no actuator movement upon loss of signal. This is the factory default setting.
- Fail to the full clockwise / extend position
- Fail to the full counterclockwise / retract position
- Fail to a preset position

NOTE: For a setting of zero input signal the system fails to minimum signal position.

a. Setting the Fail Safe Position:

1. Use the > or fl keys until io is displayed, then press the SELECT key.
2. Use the > or fl keys until FSPn is displayed, then press the SELECT key.
3. Use the > or fl keys to set the fail safe position to the required location. Setting the fail safe position to greater than full scale (101 standard), will enable fail in last position mode.
4. Press the SELECT key to save the selection.

b. Setting the Fail Safe Loss of Signal Threshold:

1. Use the > or fl keys until io is displayed, then press the SELECT key.
2. Use the > or fl keys until FStH is displayed, then press the SELECT key.
3. Use the > or fl keys to set the input threshold in percent, or units of full scale, where the fail safe function will be activated. The fail safe function will be activated whenever the input signal falls below the threshold setting. Hysteresis of 1% is automatically provided on the fail safe threshold.
4. Press the SELECT key to save the selection.



Industrial Products Group Dresser, Inc.

16240 Port Northwest Drive
Houston, Texas 77041-2645 USA
Ph: 832.590.2306
Toll Free Phone: 800.945.9898

Fax: 713.849.2879
Email: rcs@dresser.com



www.dresser.com