

ANDCO Eagle Actuator Instruction Manual

NOTICE The information contained in this manual is essential to safe, successful, long term operation of your Andco Eagle Linear Actuator. Read and follow the requirements concerning storage, installation and adjustments. Failure to do so could void the warranty covering your actuator.

This manual gives instructions for storing, installing, operating and servicing the Model 3100 Eagle linear actuator.

Refer all questions not covered in this manual to:
Dresser Inc.

16240 Port Northwest Drive
Houston, Texas 77041
Tel: 832-590-2306
Fax: 713-849-2879

Be sure to include the model and serial number located on the nameplate of your Eagle actuator in all communications and parts orders. The nameplate is located on the gear housing cover.

1.0 Storage Requirements

1. Actuators should always be stored in a clean dry environment, in a location where mechanical damage to the actuator can't accidentally occur.
2. All covers must remain in place and securely fastened.
3. All pipe plugs must remain in place and be kept tight.
4. Actuators equipped with controllers can be damaged by excessive moisture. Units so equipped should be stored in a controlled environment prior to installation. For long term storage (in excess of six weeks), desiccant bags should be placed in the control compartment. (Remove bags prior to start-up.) If the units are equipped with compartment heaters, it is advisable to have the heaters continuously energized while in storage.

2.0 Mounting Arrangements

NOTICE While it is possible to mount the actuator in any position, it is not recommended that the control compartment cover be positioned face down. In order to maximize seal integrity, the unit should be mounted with the extension rod pointed up (vertical installations) or motor up (horizontal installations).

1. A body tube adapter (57) is used for face flange or trunnion-type mounting.
2. The actuator can be clevis-mounted utilizing the clevis (29) in the extension rod (6) and the rear clevis bracket.



3.0 Installation Requirements

1. To prevent premature wear of the drive nut (7) or extension rod seal/wiper (2), verify that the alignment between the actuator mounting support and the driven equipment places no side loading on the extension rod (6) at any point throughout the full stroke.
2. Do not hammer or gouge the outside surface of the extension rod (6). This may damage the plating integrity or cause surface irregularities which can damage rod seals.
3. If the actuator is being face flange or trunnion mounted, position the body tube adapter (57) to the desired orientation.
4. Verify that the pins of the trunnion mounting configuration are parallel with the clevis pin.
5. Tighten the nut and bolt arrangement of the body tube adapter to 50-55 ft.-lbs. of torque.
6. Verify the pins of the clevis bracket and clevis (29) are parallel.
7. Apply a light film of lubricant to all pinned type connections.

NOTICE In all mounting situations, the final trimming adjustment of the actuator installation is $\pm 1/8$ inch.

8. Loosen jam nut (28).
9. Turn clevis (29) clockwise to decrease or counterclockwise to increase the actuator installed length.

CAUTION Because the thread grip is limited, make sure clevis (29) is engaged by a minimum of four (4) threads and that it does not contact drive screw (4) when extension rod (6) is fully retracted.

10. Upon completion of all mounting operations verify that the jam nut (28) is tight, and that all cotter pins have been secured.
11. The actuator must be installed and wired in accordance with local electrical codes and current edition of the National Electrical Code.
12. Route the electrical conduit up into the actuator to prevent internal condensation from running into the limit switch compartment.

CAUTION Verify that the supply voltage to the actuator matches the voltage for the nameplate (33) on the gear cover (21).

13. Keep limit switch compartment dry and clean. To minimize the possibility of condensation damage, it is suggested that moisture/gas tight conduit seals be installed at the conduit connections.
14. Dust-ignition proof actuators must have all covers secured and grounding lugs connected to a suitable grounding system before electrical circuits are energized.

4.0 Geared Position Limit Switch Adjustment

The geared position limit switch has been preset at the factory to trip and interrupt the electric control for the extend and retract positions according to specified stroke. However, should the trip points need to be readjusted to a shorter actuator stroke, the setting is to be done in accordance with the following procedure.

WARNING Disconnect all electrical power to the actuator prior to removing the position limit switch compartment cover and performing any setting adjustments.

1. Remove the position limit switch compartment cover (38) to gain access to the position switch.
2. Remove the motor pipe plug (46) for access to slot "A" located in the end of motor shaft.
3. With a manual or power screw driver rotate the motor shaft in a clockwise direction to extend or counterclockwise direction to retract the extension rod.
4. To set the extend limit switch, turn the motor shaft in a clockwise direction. Note the direction slotted shaft (48) is turning while extending extension rod to its desired position.
5. Depress the position switch plunger (47) and turn slotted shaft (48) in same direction it was turning as in step (4) and continue to turn in that direction until cam (50) flat comes in contact with micro switch (52) lever.
6. Repeat steps (4) and (5) for retract position utilizing slotted shaft (49), limit switch (53) and cam (51). Turn motor shaft in a counterclockwise direction.
7. Replace motor pipe plug (46).

8. Replace cover (38).
9. Re-energize all electrical power to actuator.

NOTICE Replace the complete geared position limit switch rather than attempting field repair.

Readjust the geared position limit switch before operating the actuator if the switch has been removed from the actuator.

5.0 Disassembly

WARNING Whenever performing any service work on your Andco actuator, disconnect all electrical power.

5.1.1 Limit Switch

1. Remove the position switch compartment cover (38).
2. Disconnect the leads to the switches (52) & (53) on the gear position limit switch assembly (36), making sure they are marked for reconnection to the proper terminals. The geared position limit switch (36) is retained by hardware (39) and (40). Remove the limit switch by removing the hardware and pulling the switch out of the housing (58).

5.1.2 Motor

3. Disconnect motor leads at the terminal strip (37) making sure they are marked for reconnection to the proper terminals.
4. Remove the motor (27) by removing retaining hardware (41) and (42) and pulling motor out of the actuator housing.
5. To remove motor pinion, remove retaining ring (43) and loosen set screw (45), and slide pinion (44) off shaft.

5.1.3 Clevis

6. Loosen jam nut (28) from face of extension rod (6).
7. Remove clevis (29) by unthreading from extension rod (6).

5.1.4 Drive Screw

8. Clamp actuator housing (26) in a soft jawed vise. With a strap wrench on the body tube (5), unthread body tube from actuator housing. The threads are Loctited, so it may be necessary to apply heat in this area. Do not exceed 350° F maximum surface temperature.
9. Remove gear compartment cover (21).
10. Use non-ferrous block to hold main gear (19) from rotating and remove flex nut (17) and gear.
11. Remove intermediate gear (23).
12. Remove woodruff key (14) and gear spacer (13) from the drive screw.

13. Reinstall a new flex nut (17) 2-3 turns and tap lightly with a soft face hammer on end of drive screw (4).
14. Once drive screw moves freely through bearings (12), remove flex nut and complete removal of drive screw.

5.1.5 Drive Nut

15. Clamp drive nut (7) in a soft jawed vise. With a spanner wrench in holes of extension rod (6) unthread from each other. The threads are Loctited, so it may be necessary to apply heat in this area. Do not exceed 350° F maximum surface temperature.

6.0 Reassembly

1. To reassemble the actuator reverse the above procedure including the following information.
2. Clean threads and use Loctite 242 on threads when reassembling drive nut (7) to extension rod (6) and body tube (5) to main housing (26).
3. If disassembled per previous steps, discard flex nuts (1) and (17) and replace with new.
4. The actuator is to be lubricated before being returned to operation. Use acceptable lubricant from listing in Section 5.1. Drive screw (4) is lubricated by filling body tube (5) with proper amount of lubricant through hole in main housing (26) where limit switch (36) drive engages helical gear (9).
5. After completion of reassembly, mounting adjustment can be made by threading clevis (29) in or out of extension rod (6) to suit. Note: Thread grip is limited, make sure clevis is engaged by minimum of four threads and that it does not contact drive screw (4) when extension rod (6) is fully retracted.

7.0 Lubrication Instructions

Every Eagle linear actuator has been lubricated for life at the factory and should not require further lubrication if operated at normal duty cycle at rated thrust and in ordinary environmental conditions. However, if the unit is disassembled, it should be cleaned and lubricated as discussed below. The amount of lubricant in each actuator depends on the size and stroke of the actuator as shown below.

Stroke (Inches)	Actuator Lubricant Amount (Body Tube) (Pounds)
6	.22
12	.36
18	.51
24	.66
30	.81
36	.96

7.1 Acceptable Lubricants

Standard lubricants for use in the actuator are charted below. Acceptable substitute lubricants are also listed.

Recommended Name	Manufacturer
AeroShell Grease 6	Shell Oil Products
Substitute	
Lubriplate MAG-1	Fiske
Litholene HEP1	ARCO
Mobilux EP1	Mobil
Gulfcrown EP1	Gulf

8.0 Troubleshooting Guide

In the event of a problem with your Andco actuator, make the following preliminary checks before calling the factory for assistance.

1. Actuator's rod will not extend or retract.
 - a. Check for a blown fuse or circuit breaker in the circuit.
 - b. Check for a loose wire.
 - c. Check motor for overheating and activation of the thermal switch.
 - d. Check for correct limit switch setting.
 - e. Check any binding in the load being actuated.
 - f. Check for an open capacitor lead.
 - g. Check for a worn drive nut, by disconnecting actuator from load and pulling or pushing on extension rod.
2. Actuator only actuated in one direction.
 - a. Check for any open wiring.
 - b. Check that position limit switch is properly adjusted.
 - c. Check for excessive external load on the actuator in one direction.
3. Actuator is excessively noisy.
 - a. Check for a bad bearing.
 - b. Check for a bad gear (chipped tooth, missing teeth, etc.)
 - c. Check for a bent screw.
4. Actuator exhibits high motor current.
 - a. Check for external binding related to the load being actuated.
 - b. Check for excessive external load being actuated.
 - c. Check for loss of lubricant.
 - d. Check rod for excessive contaminate.
 - e. Check for low line voltage.

If after making all of the above checks and you still have a specific problem with your Andco Actuator, contact Dresser Inc. for further assistance.

9.0 Optional Equipment

9.1 Gear Drive Potentiometer

This optional assembly is direct driven by the operation of the actuator and gives the capability of providing a continuous, linear output control signal directly proportional to the actuator's stroke. The signal can be interfaced with automatic control equipment to position or sense the actuator at any desired stroke between fully extended and fully retracted.

The potentiometer assembly is mounted directly to and driven by the geared position limit switch. Characteristics of the potentiometer are 1000 ohm total resistance 1.0% linearity, 1 watt at 158° F power rating and 400 Vdc maximum input voltage. Input gearing to the potentiometer is factory selected to accommodate the full range of actuator strokes and acme screw pitches. The potentiometer has been factory adjusted so the 0 and 1000 ohm resistance points correspond, respectively, to the fully extended and fully retracted rod positions. Field adjustments may be made by loosening jam nut holding potentiometer (64) to mounting bracket (65). Rotate potentiometer to desired position and tighten jam nut.

For units that utilize the last portion of the actuator stroke only; the potentiometer gearing must be disconnected if the unit is to be retracted beyond the "zero" point.

9.2 Dust-Ignition Proof Enclosure

Class II, Division 1, Groups E, F & G.

Indoor and Outdoor Hazardous Locations.

Actuators provided to comply with this NEC specification must have properly installed electrical access covers to exclude ignitable amounts of dust. When reinstalling these covers make sure the mating seating surfaces and gaskets are clean and the attachment bolts are securely tightened. If the motor end bell pipe plug has been removed to adjust the actuator, that pipe plug must be reinstalled tightly. The actuators must be able to operate at full rating without developing surface temperatures high enough to cause excessive dehydration or gradual carbonization of any organic dust deposits on the actuator enclosure.

The grounding lug on the actuator enclosure exterior must be wired to a suitable grounding system with a minimum of #10 AWG wire as noted in the electric wiring diagram provided with the actuator.

10.0 Suggested Spare Parts List

Description	Item
1. Drive Nut	(7)
2. Position Limit Switch	(36)
3. Micro Switches	(52) & (53)
4. Body Tube/End Cap	(5)
5. Motor	(27)
6. Gasket and Seal Kit to include:	
Wiper Rod Seal	(2)
O-Rings	(30), (31), & (55)
Sealing Washer	(35)
Gaskets	(25) & (56)

Eagle Outline Dimension Drawing

"T" Adjustable Dimension		
Stroke	Inches	Millimeters
6	2.38 - 2.88	(60.45 - 73.15)
12	2.38 - 8.00	(60.45 - 203.20)
18	2.38 - 14.00	(60.45 - 355.60)
24	2.38 - 20.00	(60.45 - 508.00)
30	8.38 - 26.00	(12.85 - 660.40)
36	14.38 - 32.00	(365.25 - 812.80)

NOTES:

1. Unbracketed dimensions are in inches.
2. Bracketed dimensions () are in millimeters
3. Dimensions shown with actuator fully retracted

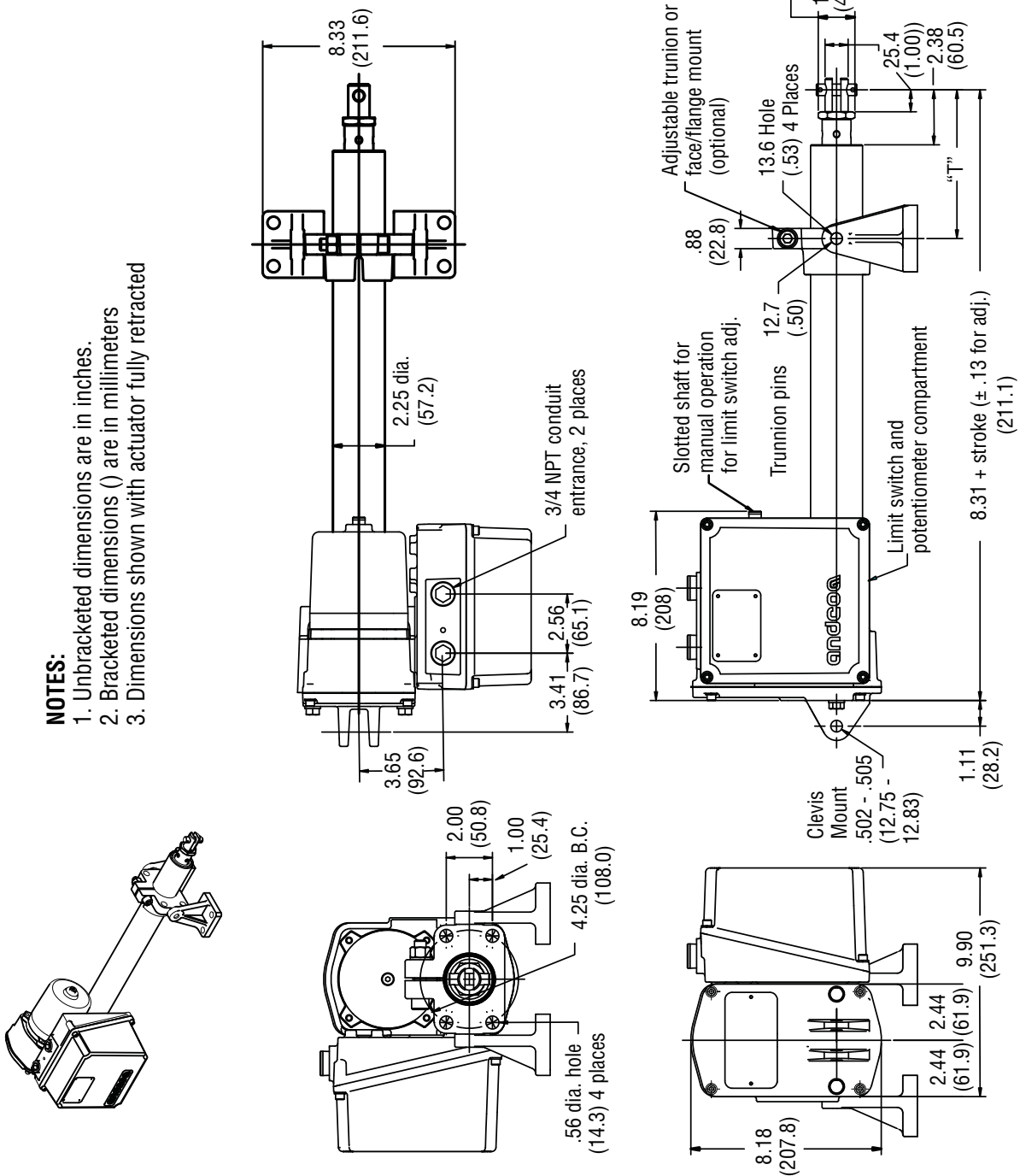

Eagle Parts Drawing

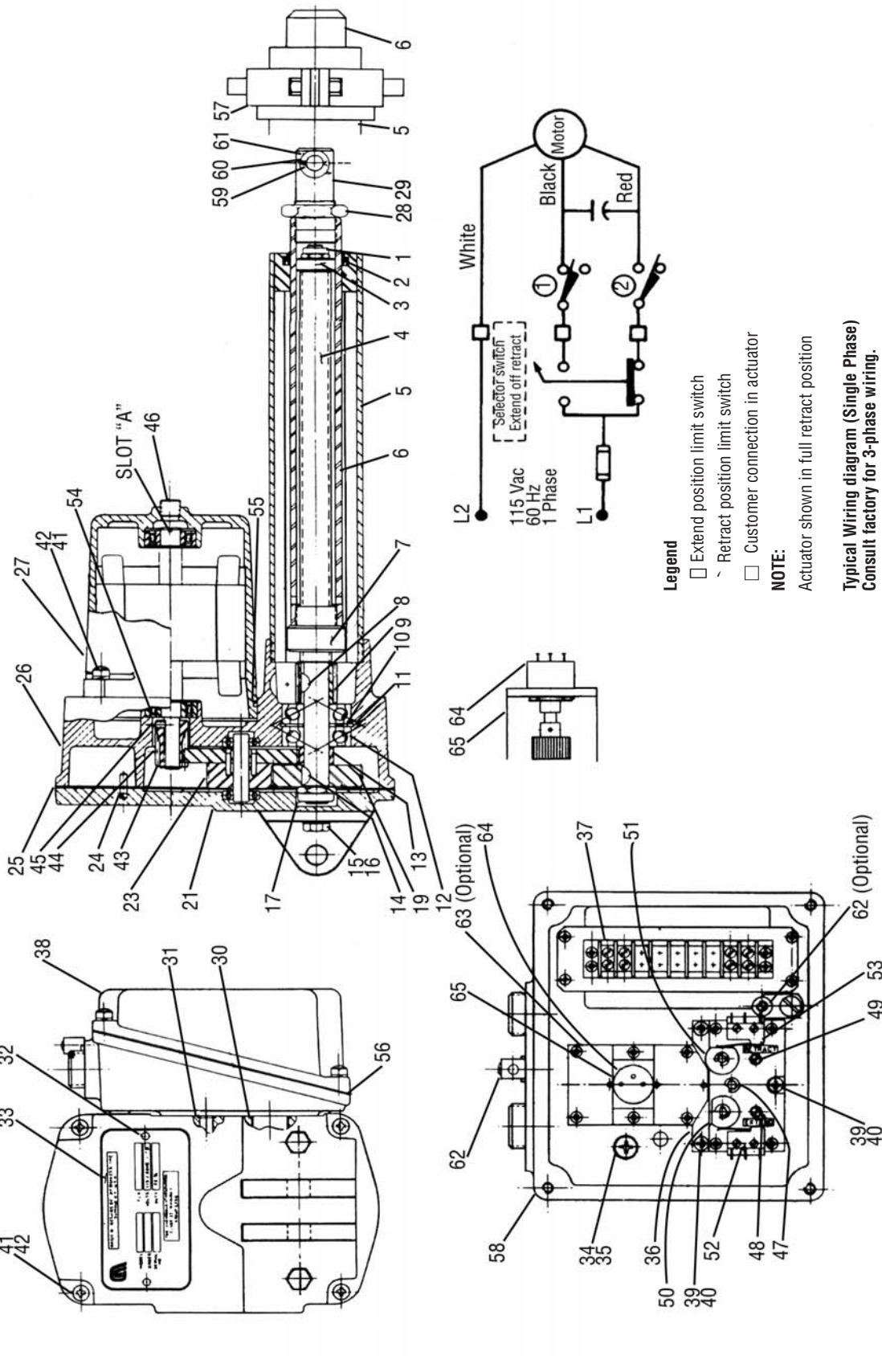

Parts List

1. Flex nut
2. Wiper seal
3. Support washer
4. Drive screw
5. Body tube/End Cap
6. Extension rod
7. Drive nut
8. Key
9. Helical gear
10. Spacer
11. Retaining ring
12. Bearing
13. Spacer
14. Key
15. Hex bolt
16. Lock washer
17. Flex nut
19. Main drive gear
20. Unassigned
21. Cover
22. Unassigned
23. Intermediate gear
24. Pin
25. Gasket
26. Body housing
27. Motor
28. Jam nut
29. Clevis
30. O-ring
31. O-ring
32. Fastener
33. Nameplate
34. Screw
35. Seal washer
36. Position limit switch
37. Capacitor/terminal strip sub-assembly
38. Cover
39. Screw
40. Lock washer
41. Screw
42. Lock washer
43. Retaining ring
44. Drive pinion
45. Set screw
46. Plug
47. Plunger
48. Shaft
49. Shaft
50. Cam
51. Cam
52. Micro switch
53. Micro switch
54. Bearing
55. O-ring
56. Gasket
57. Body tube adapter
58. Limit switch housing
59. Clevis pin
60. Cotter pin
61. Flat washer
62. Grounding lug (optional)
63. Gear driven potentiometer (optional)
64. Potentiometer
65. Potentiometer mounting bracket

**Industrial Products Group
Dresser, Inc.**

16240 Port Northwest Dr.
Houston, TX 77041-2645

Ph: 832.590.2306

Fax: 713.849.2879

Toll Free Phone: 800.945.9898

Email: andco@dresser.com



www.dresser.com

©2008 Dresser, Inc.

Andco and Dresser are registered trademarks of Dresser, Inc.

Eagle IOM
4.09